

# **OPERATOR'S MANUAL**

**INCLUDING: OPERATION, INSTRUCTION, INSTALLATION, MAINTENANCE AND PARTSBOOK**

---

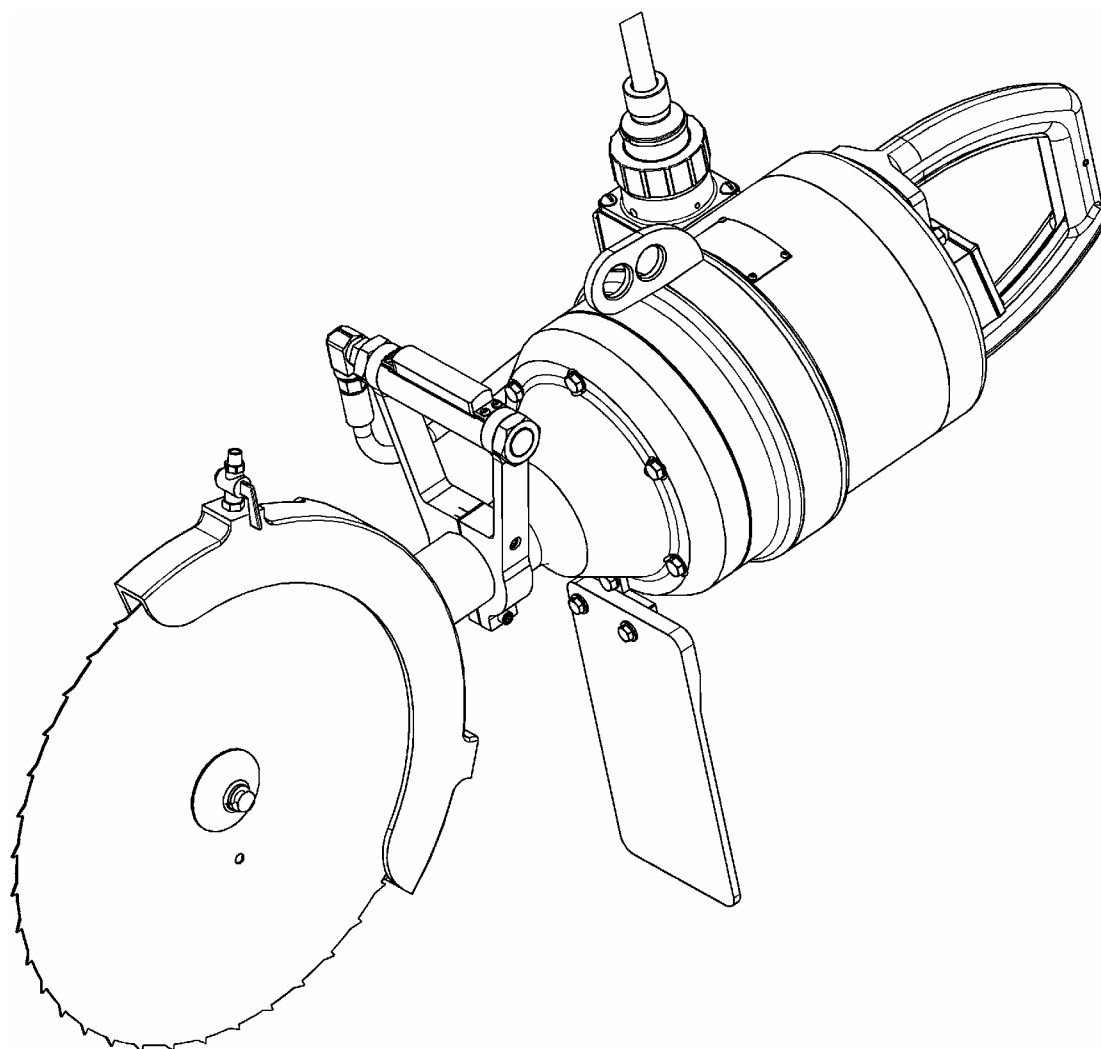
**IMPORTANT: READ THIS MANUAL CAREFULLY BEFORE INSTALLING, OPERATING OR  
SERVICING THIS TOOL.**




---

## **HOG SPLITTING SAW with ANTI-TIE DOWN**
















### **TOOL DATA**

MODEL: 160-JB-A  
ASSEMBLY NO. 1600410  
TYPE: ELECTRICAL OPERATED  
WITH ANTI TIE DOWN  
NET WEIGHT: 130 LBS (59 KG)  
MOTOR HORSEPOWER: 3HP



 <b>WARNING</b>	= Hazards or unsafe practices which could result in severe personal injury, death or substantial property damage.
 <b>CAUTION</b>	= Hazards or unsafe practices which could result in minor personal injury, product or property damage.
 <b>NOTICE</b>	= Important installation, operation or maintenance information.

## OPERATING AND SAFETY INSTRUCTIONS

-  **WARNING** DO NOT OPERATE THIS TOOL UNTIL YOU HAVE READ AND UNDERSTOOD THE SAFETY INSTRUCTIONS AND OPERATING MANUALS.
-  **WARNING** DO NOT OPERATE THIS TOOL UNTIL YOU HAVE RECEIVED TRAINING IN THE HANDLING, OPERATION AND USE OF THIS TOOL.
-  **WARNING** STOP USING A MALFUNCTIONING OR DEFECTIVE TOOL IMMEDIATELY. REPORT ANY PROBLEMS OR DEFECTS TO YOUR SUPERVISOR FOR REMOVAL OF THE TOOL FROM SERVICE.
-  **WARNING** DO NOT ATTEMPT TO REPAIR THE TOOL YOURSELF.
-  **WARNING** DO NOT ALLOW UNAUTHORIZED PERSONS TO USE TOOL.
-  **WARNING** REMOVE AND DISCONNECT POWER FROM THE TOOL WHEN TOOL IS LEFT UNATTENDED OR IS NOT IN USE.
-  **WARNING** NEVER TIE DOWN, BYPASS, ALTER OR MODIFY THE ACTIVATING SWITCHES OR TRIGGERS OF THIS TOOL.
-  **WARNING** NEVER MAKE ALTERATIONS OR MODIFICATIONS TO THIS TOOL.
-  **WARNING** BE CONSTANTLY AWARE AND ALERT FOR UNSAFE CONDITIONS AND REPORT THEM IMMEDIATELY TO YOUR SUPERVISOR.
-  **WARNING** NEVER PLACE YOUR HAND OR ANY PART OF YOUR BODY IN THE CUTTING PATH OF THE TOOL.
-  **WARNING** NEVER ALLOW ANYONE ELSE TO PLACE THEIR HANDS OR ANY PART OF THEIR BODY IN THE CUTTING PATH OF THE TOOL.
-  **WARNING** DO NOT ACTIVATE CONTROL SWITCHES OR TRIGGERS OF THIS TOOL UNLESS YOU INTEND TO TEST OR OPERATE THIS TOOL.
-  **WARNING** DO NOT USE THIS TOOL FOR ANY PURPOSE OTHER THAN IT'S INTENDED PURPOSE.
-  **CAUTION** WHEN OPERATING THIS TOOL WEAR THE PROTECTIVE GEAR AND SAFETY EQUIPMENT SUPPLIED TO YOU.
-  **WARNING** THE NOISE EMISSION (SOUND PRESSURE LEVEL) AT THE WORKSTATION MAY EXCEED 80 dB (A). EAR AND SOUND PROTECTION GEAR IS REQUIRED.

## OPERATING INSTRUCTIONS

**⚠ WARNING** ONLY TRAINED PERSONNEL ARE TO OPERATE THIS TOOL.

1. TO ENSURE TOOL IS OPERATING PROPERLY, PERFORM FOLLOWING STEPS AT START OF EACH SHIFT:
  - MAKE SURE TOOL MOVES UP AND DOWN FREELY WHILE HANGING FROM BALANCER OVERHEAD.
  - WITH POWER TO TOOL TURNED ON, TEST TRIGGER FOR PROPER OPERATION.
  - DEPRESS EACH TRIGGER SEPARATELY. TOOL SHOULD NOT ACTIVATE. DEPRESS BOTH TRIGGERS. TOOL SHOULD ACTIVATE.
  - IF TOOL HAS "ANTI-TIE DOWN" OPTION, BOTH TRIGGERS MUST BE DEPRESSED SIMULTANEOUSLY FOR TOOL TO ACTIVATE.
  - THIS TOOL HAS AN ELECTRO-MAGNETIC DISC BRAKE ASSEMBLY THAT ACTIVATES WHEN EITHER TRIGGER IS RELEASED. THIS ELIMINATES COASTING OF SAW BLADE WHEN TOOL IS DEACTIVATED.
2. TO PERFORM WORK, HOLD TOOL FIRMLY AT BOTH HANDLES. SQUEEZE TRIGGERS TO ACTIVATE TOOL.
3. SAW CARCASS THROUGH THE TAILBONE, MOVING DOWNWARD IN A STRAIGHT LINE.
4. DO NOT EXERT EXCESSIVE PRESSURE. ALLOW TIME FOR TOOL TO CUT.
5. CUT DOWNWARD IN A STRAIGHT LINE THROUGH SHOULDER AND NECK OF CARCASS.

## MAINTENANCE

**⚠ WARNING** ONLY TRAINED AND QUALIFIED PERSONNEL ARE TO PERFORM MAINTENANCE AND SERVICE TO THIS TOOL.

THE COMPRESSED AIR DISTRIBUTION SYSTEM MUST BE LARGE ENOUGH TO SUPPLY AN ADEQUATE VOLUME OF CLEAN AND DRY COMPRESSED AIR TO THE TOOL.

TOOL REQUIRES GREASING AFTER EVERY 40 HOURS OF OPERATION. GREASE ONE LOCATION USING KENTMASTER GREASE (PART NO. 7903070).

## BLADE REMOVAL AND CLEANING

**⚠ WARNING** ALWAYS DISCONNECT POWER SUPPLY FROM TOOL BEFORE INSTALLING OR REMOVING BLADE FROM TOOL.

**⚠ WARNING** ALWAYS WEAR WIRE MESH GLOVES WHEN INSTALLING OR REMOVING BLADE FROM TOOL.

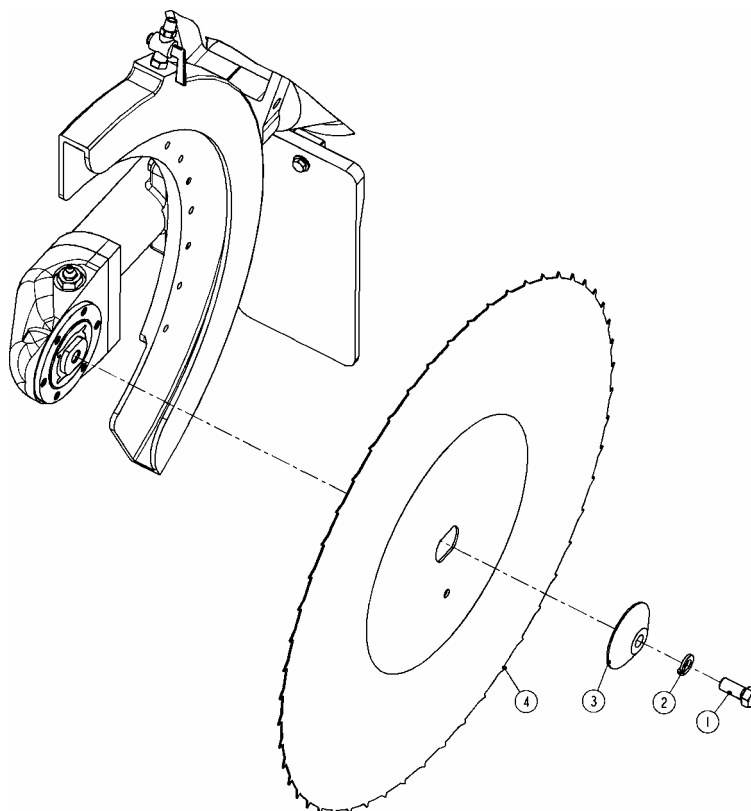
1. REMOVE SCREW (ITEM NO. 1, FIG. NO. 1).
2. REMOVE PARTS (ITEM NO. 2-4, FIG. NO. 1).
3. CLEAN ALL PARTS REMOVED WITH SOAP AND WATER.
4. SHARPEN OR REPLACE BLADES WHEN NECESSARY AND LUBRICATE ALL PARTS.
5. REASSEMBLE IN REVERSE ORDER.

## TROUBLE SHOOTING

IF THE BRAKE WON'T STOP THE BLADE, CHECK FOLLOWING:

1. SWITCHES IN THE HANDLES (ITEMS 2000710 & 2000720 ON 160-JB. ITEMS 2000690 & 2000700 ON 1600-JB-A).
2. THE POWER SUPPLY CONVERTOR – RECTIFIER, PLACED IN THE WIRE BOX (ITEM 2000300).

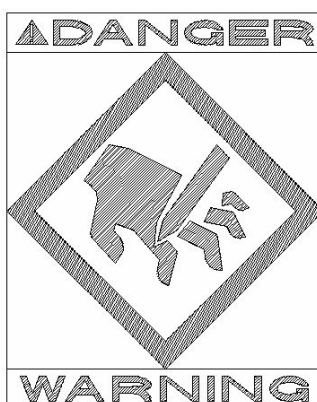
CHANGE ONE PART AT THE TIME AND TEST THE MACHINE TO DETERMINE WHICH ONE WAS THE DAMAGED PART.



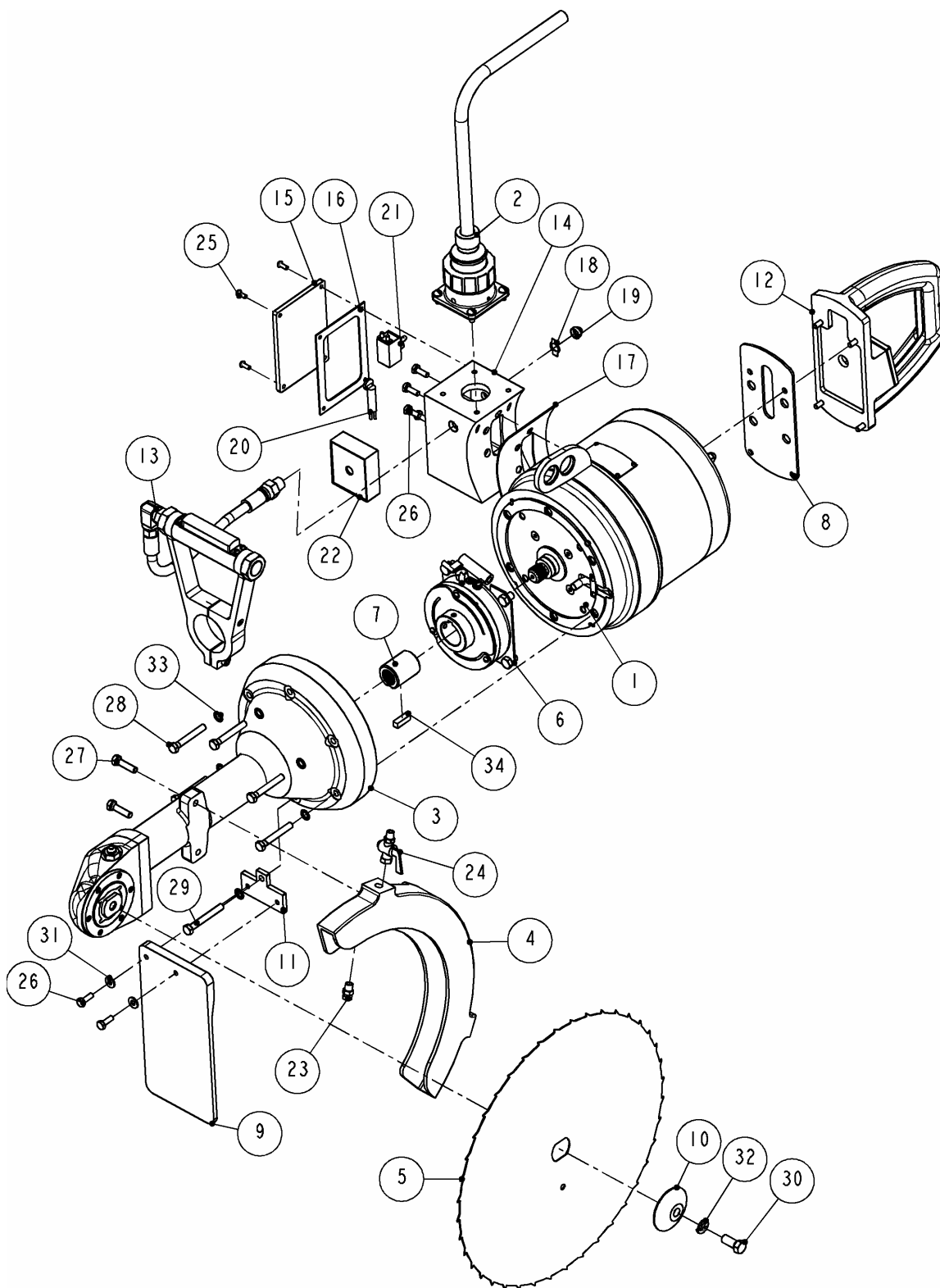
**Figure 1 MODEL 160 – BLADE REPLACEMENT**

**SERVICE**

1. KEEP GOOD RECORDS OF ALL SERVICE ACTIVITY AND INCLUDE TOOL IN PREVENTIVE MAINTENANCE PROGRAM.
2. USE ONLY GENUINE KENTMASTER REPLACEMENT PARTS TO ASSURE PROPER PERFORMANCE OF TOOL.
3. CONTACT THE KENTMASTER SUPPLIER NEAREST YOU FOR PARTS AND CUSTOMER SERVICE INFORMATION.



**PARTS BOOK**  
**160-JB-A**



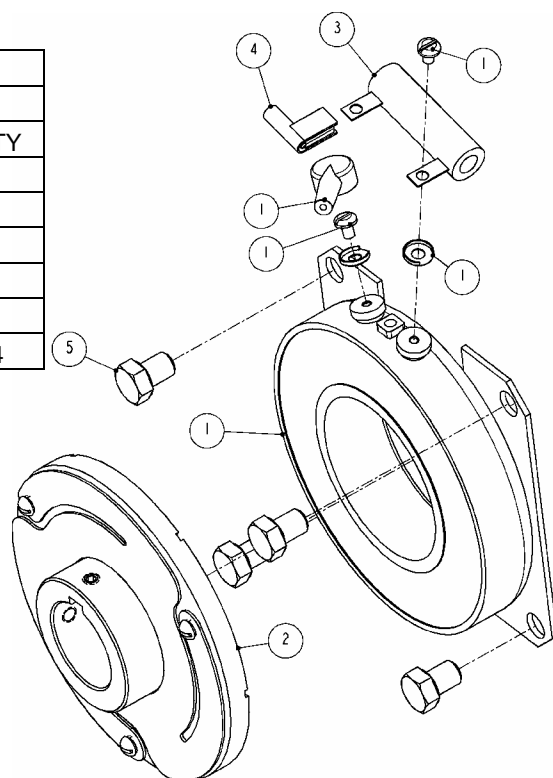
**Figure 2 MODEL "160-JB-A" – MAIN ASSEMBLY**

<b>1600410: 160-JB-A, HOG SPLITTING SAW w/ATD</b>			
ITEM	PART #	DESCRIPTION	QTY
1	<b>OPTIONS</b>	MOTOR ASSEMBLY, 3HP	1
2	1302950	POWER SUPPLY, NON 42V, ATD (for all motors except 42V)	1
	1302965	POWER SUPPLY, 42V, ATD (only for 42V motors)	1
3	1302970	DRIVE SHAFT HOUSING - NOSE, STANDARD TORQUE	1
	1302552	DRIVE SHAFT HOUSING - NOSE, HIGH TORQUE	1
4	1302500	GUARD FOR 16" BLADE	1
5	4000550	16" SAW BLADE, 40 TEETH, DOUBLE SKIP TOOTH	1
	4000180	16" SAW BLADE, 120 TEETH, THIN RIM	1
	4000490	16" SAW BLADE, 40 TEETH, DOUBLE SKIP TOOTH, HEAVY-DUTY	1
6	2000201	ELECTRO-MAGNETIC BRAKE,90VDC (for all motors except 42V)	1
	2000350	ELECTRO-MAGNETIC BRAKE,42VDC (only for 42V motors)	1
7	1000180	SLEEVE	1
8	1001940	INSULATION PLATE	1
9	1300180	SPLASH GUARD	1
10	1300830	FLANGE - SAW BLADE	1
11	1302150	MOUNTING PLATE	1
12	1302550	REAR HANDLE ASSEMBLY, ATD	1
13	1302560	FORWARD HANDLE ASSEMBLY, ATD	1
14	1302630	WIRE BOX	1
15	1302640	COVER	1
16	1302650	GASKET	1
17	1302660	GASKET	1
18	2000130	ON-OFF PLATE	1
19	2000140	BOOT, TOGGLE SWITCH	1
20	2000300	POWER SUPPLY CONVERTOR RECTIFIER	1
21	2000730	SWITCH	1
22	2009130	TIMER	1
23	7011650	SPRAY NOZLE	1
24	7025110	SHUT OFF VALVE	1
25	8029040	SCREW	4
26	8411060	SCREW	6
27	8413100	SCREW	2
28	8413180	SCREW	5
29	8413200	SCREW	1
30	8417580	SCREW	1
31	8505100	WASHER	2
32	8506170	WASHER	1
33	8507150	WASHER	8
34	8606080	KEY	1

**Figure 3 BOM FOR MODEL "160-JB-A"**

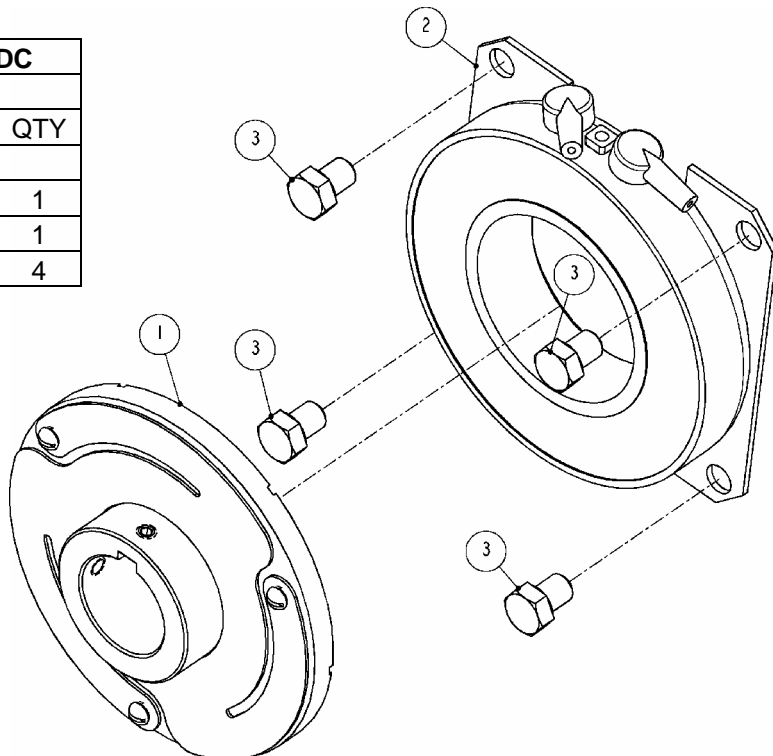
**ELECTRO-MAGNETIC BRAKE**

<b>2000201: ELECTRO-MAGNETIC BRAKE, 90VDC</b>				
ITEM	PART #		DESCRIPTION	QTY
1	2000200	2000211	MAGNETIC COIL, 90VDC	1
2		2000220	ARMATURE ASSEMBLY	1
3	2020010		RESISTOR	1
4	2506105		FEMALE QUICK DISCONNECT	1
5	8415040		SCREW	4



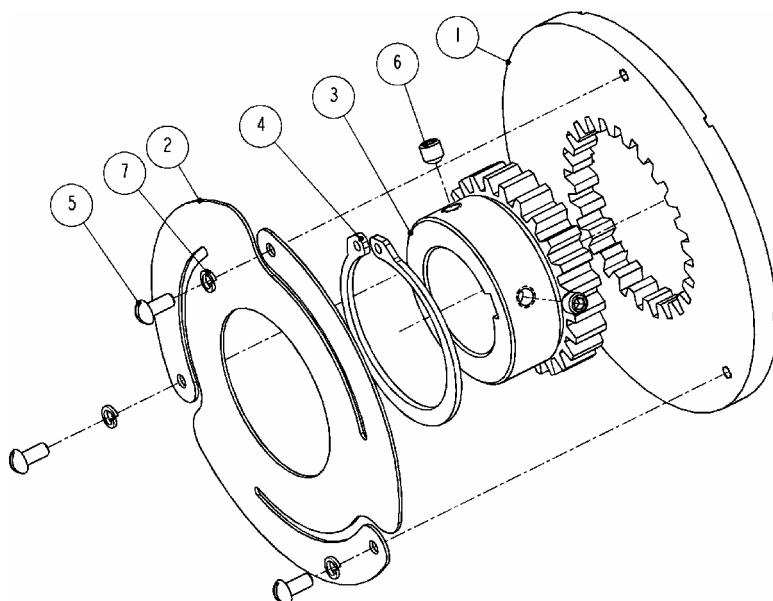
**Figure 4 2000201: ELECTRO-MAGNETIC BRAKE, 90VDC**

<b>2000350: ELECTRO-MAGNETIC BRAKE, 42VDC</b>				
ITEM	PART #	DESCRIPTION	QTY	
1	2000220	ARMATURE ASSEMBLY	1	
2	2000360	MAGNETIC COIL, 42VDC	1	
3	8415040		SCREW	4

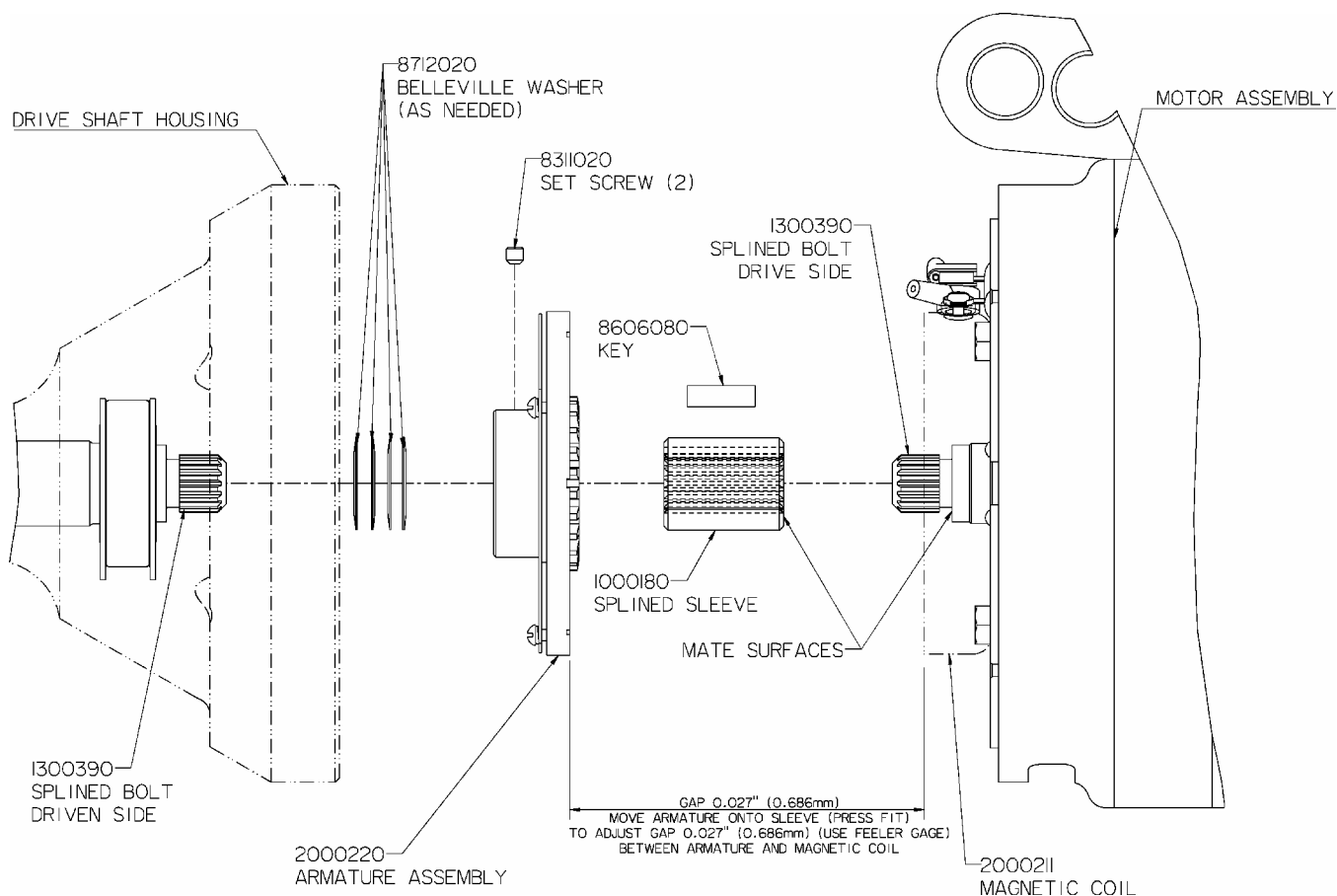


**Figure 5 2000350: ELECTRO-MAGNETIC BRAKE, 42VDC**

2000220: ARMATURE ASSEMBLY			
ITEM	PART #	DESCRIPTION	QTY
1	2000230	ARMATURE	1
2	2000240	RELEASE SPRING	1
3	2000250	DRIVEN HUB	1
4	5102150	RETAINING RING	1
5	8028030	SCREW	3
6	8311020	SET SCREW	2
7	8506580	WASHER	3



**Figure 6 2000220: ARMATURE ASSEMBLY**



**Figure 7 BRAKE ADJUSTMENT**

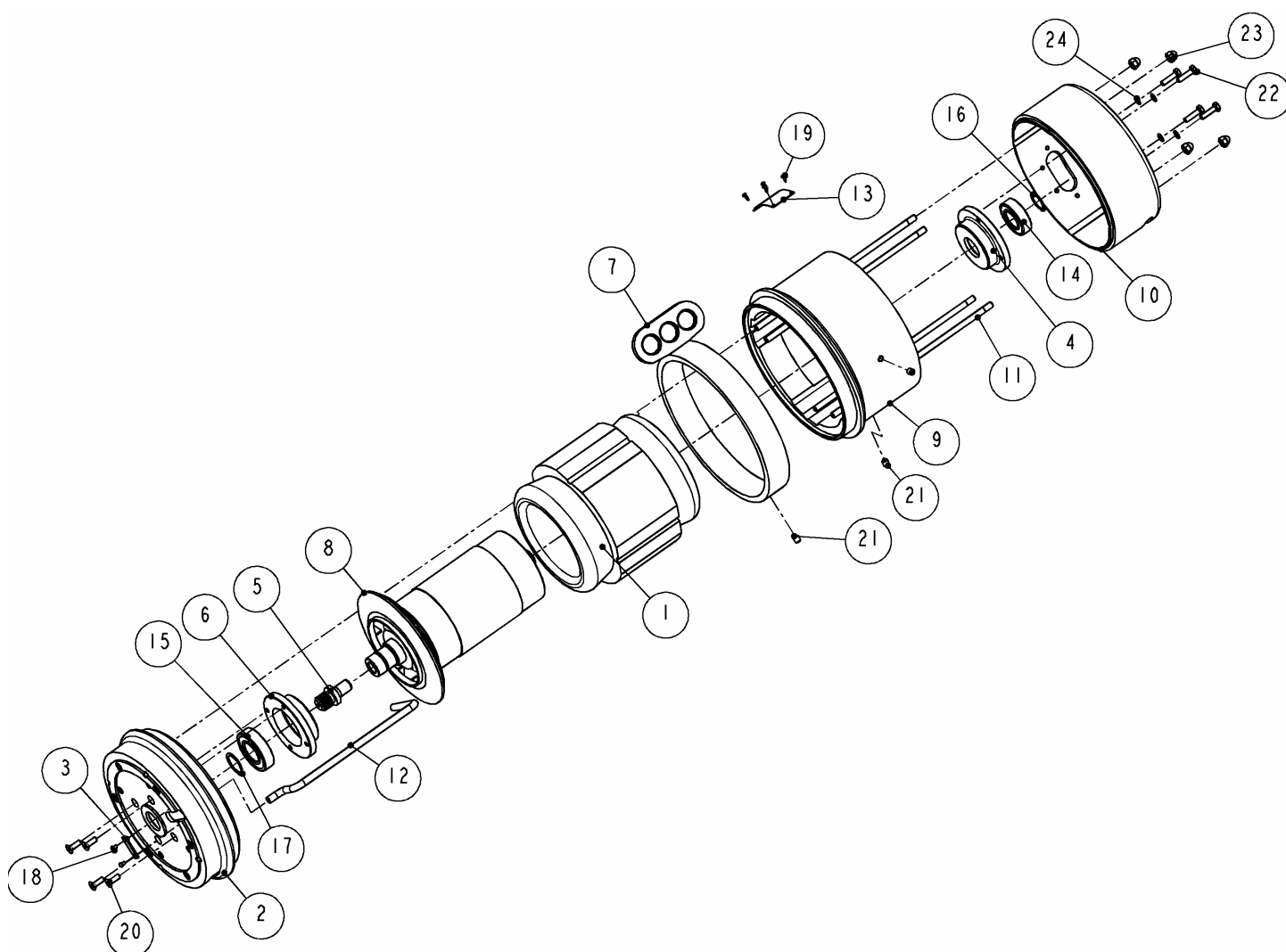


## BRAKE ADJUSTMENT

### BRAKE ADJUSTMENT PROCEDURE:

1. PRESS SPLINED SLEEVE (1000180) AND KEY (8606080) INTO ARMATURE ASSEMBLY (2000220).
2. SLIDE SPLINED SLEEVE (1000180) ONTO SPLINED BOLT - DRIVE SIDE (1300390) ALL THE WAY AGAINST BOLT SURFACE.
3. ADJUST GAP BETWEEN ARMATURE (2000220) AND COIL (2000211) - USE FEELER GAGE - BY MOVING ARMATURE (2000220) ONTO SPLINED SLEEVE (2000211). IF USED BRAKE WITH RESISTOR GAP IS 0.027" (0.686mm). IF USED BRAKE WITHOUT RESISTOR GAP IS 0.050" (1.27mm).
4. AFTER THE GAP IS ADJUSTED TIGHTEN TWO SET SCREWS (8606080).
5. USE BELLEVILLE WASHER (8712020) (AS NEEDED) BETWEEN SPLINED SLEEVE (1000180) AND BOLT - DRIVEN SIDE (1300390).

## MOTOR ASSEMBLY, 3HP

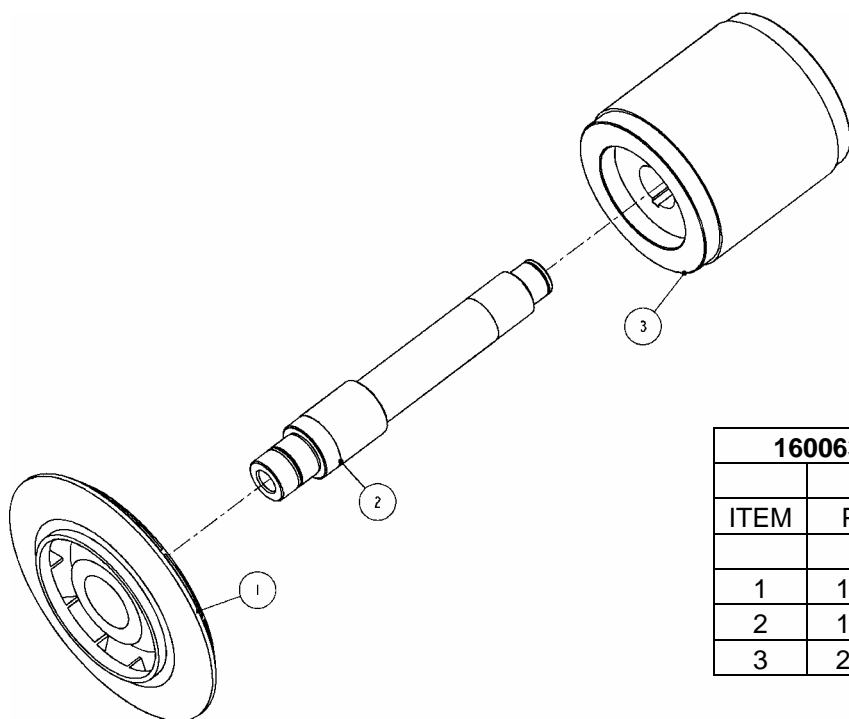


**Figure 8 3HP MOTOR ASSEMBLY**

MOTOR ASSEMBLY 416V, 3PH, 50HZ, 3HP, 4.3 AMPS	1600830-416-350	2340130
MOTOR ASSEMBLY 208V, 3PH, 50HZ, 3HP, 8.3 AMPS	1600830-208-350	2340130
MOTOR ASSEMBLY 380V, 3PH, 50HZ, 3HP, 5.1 AMPS	1600820-380-350	2340120
MOTOR ASSEMBLY 220V, 3PH, 50HZ, 3HP, 8.8 AMPS	1600820-220-350	2340120
MOTOR ASSEMBLY 230V, 3PH, 50HZ, 3HP, 8.8 AMPS	1600810-230-350	2340110
MOTOR ASSEMBLY 115V, 3PH, 50HZ, 3HP, 17.6 AMPS	1600810-115-350	2340110
MOTOR ASSEMBLY 42V, 3PH, 50HZ, 3HP, 47.0AMPS	1600800	2340100
MOTOR ASSEMBLY 460V, 3PH, 60HZ, 3HP, 4.1AMPS	1600830-460-360	2340130
MOTOR ASSEMBLY 230V, 3PH, 60HZ, 3HP, 8.2AMPS	1600830-230-360	2340130
MOTOR ASSEMBLY 550V, 3PH, 60HZ, 3HP, 3.8AMPS	1600850	2340150
MOTOR ASSEMBLY 380V, 3PH, 60HZ, 3HP, 5.0AMPS	1600840-380-360	2340140
MOTOR ASSEMBLY 220V, 3PH, 60HZ, 3HP, 8.6AMPS	1600840-220-360	2340140
<b>MOTOR OPTION DESCRIPTION</b>	<b>MOTOR ASSEMBLY</b>	<b>STATOR</b>
<b>160-JB AND 160 JB-A MOTOR ASSEMBLY</b>		

<b>16008 : MOTOR ASSEMBLY, 3HP</b>			
<b>ITEM</b>	<b>PART #</b>	<b>DESCRIPTION</b>	<b>QTY</b>
1	<b>OPTIONS</b>	STATOR	1
2	1000070	MOTOR, FRONT END BELL	1
3	1000190	CLAMP	1
4	1300070	HOUSING - REAR MOTOR BRG.	1
5	1300390	SPLINE BOLT - DRIVE	1
6	1300710	HOUSING - FRONT MOTOR BRG.	1
7	1302173	HANGER	1
8	1600630	ROTOR ASSEMBLY, 3 HP	1
9	1600640	MOTOR SHELL	1
10	1600680	MOTOR END BELL - REAR	1
11	1600690	ROD	4
12	1600710	WIRE CONDUICT	1
13	2000040	NAME PLATE	1
14	3204050	BEARING	1
15	3204060	BEARING	1
16	5100980	RETAINING RING	1
17	5101180	RETAINING RING	1
18	8026020	SCREW	2
19	8081020	SCREW	4
20	8241060	SCREW	4
21	8313030	SET SCREW	3
22	8411080	SCREW	4
23	8501130	NUT	4
24	8507100	WASHER	4

**Figure 9 BOM FOR 3HP MOTOR ASSEMBLY**



<b>1600630: ROTOR ASSEMBLY, 3 HP</b>			
ITEM	PART #	DESCRIPTION	QTY
1	1600730	IMPELLER	1
2	1600620	SHAFT	1
3	2340610	ROTOR	1

**Figure 10 ROTOR ASSEMBLY, 3HP**

Rotor- Shaft – Impeller Assembly (Item 1600730) has to be balanced.

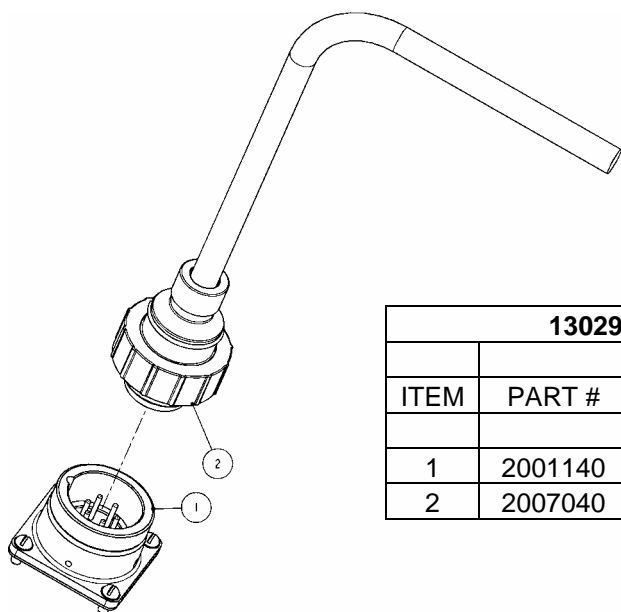
### **MOTOR DISASSEMBLY AND REASSEMBLY PROCEDURE**

1. RODS (ITEM 1600690) ARE ASSEMBLED TO BELL. AVOID HITTING WINDINGS OF STATOR WITH LOOSE ENDS OF RODS.
2. USING A GEAR PULLER, PULL HOUSINGS (ITEMS 4 AND 6, FIG. 8) FROM SHAFT (ITEM 8, FIG 8)
3. PULL STATOR (ITEM 1, FIG. 8) OUT OF SHELL (ITEM 9, FIG.8). (APPLYING HEAT (ABOUT 200° F, 93° C) TO SHELL WILL EXPAND IT. STATOR WILL BE EASIER TO REMOVE.

TO REASSEMBLY MOTOR REVERSE STEPS 1 TO 3.

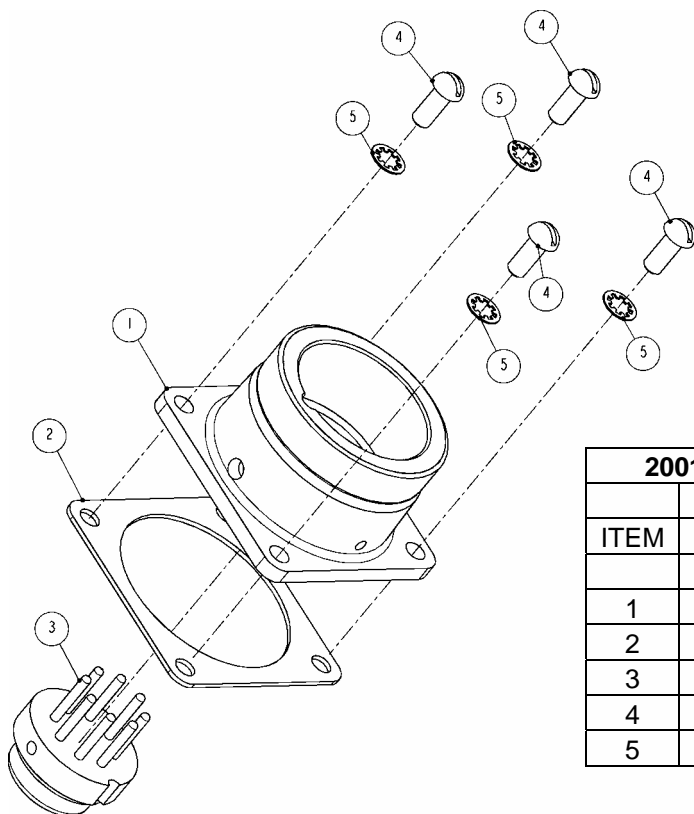
**POWER SUPPLY**

**POWER SUPPLY FOR NON 42V MODELS WITH ATD**



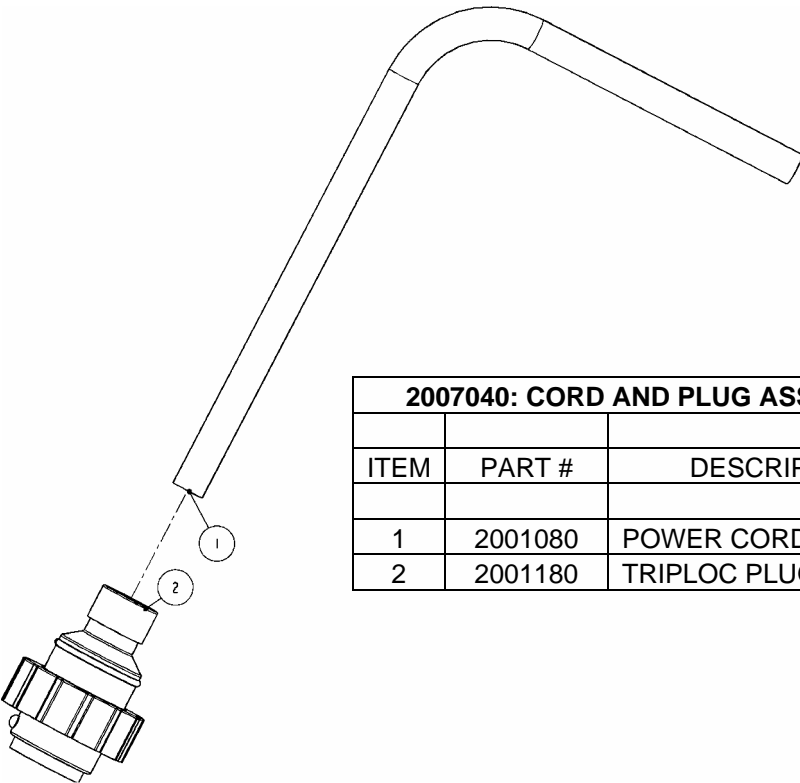
1302950: POWER SUPPLY, NON 42V, ATD			
ITEM	PART #	DESCRIPTION	QTY
1	2001140	WATERPROOF RECEPTACLE, 8 WIRE	1
2	2007040	CORD AND PLUG ASSEMBLY (14/7)	1

**Figure 11 1302950: POWER SUPPLY, NON 42V, ATD**



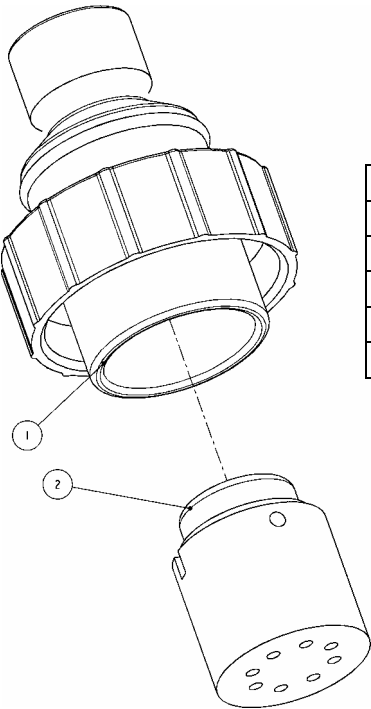
2001140: WATERPROOF RECEPTACLE, 8 WIRE			
ITEM	PART #	DESCRIPTION	QTY
1	2001150	TRIPLOC HOUSING ONLY	1
2	2001160	GASKET	1
3	2001170	MALE PLUG	1
4	8031050	SCREW	4
5	8507100	WASHER	4

**Figure 12 2001140: WATERPROOF RECEPTACLE, 8 WIRE**



<b>2007040: CORD AND PLUG ASSEMBLY (14/7)</b>			
ITEM	PART #	DESCRIPTION	QTY
1	2001080	POWER CORD (20FT)	1
2	2001180	TRIPLOC PLUG, 8 WIRE	1

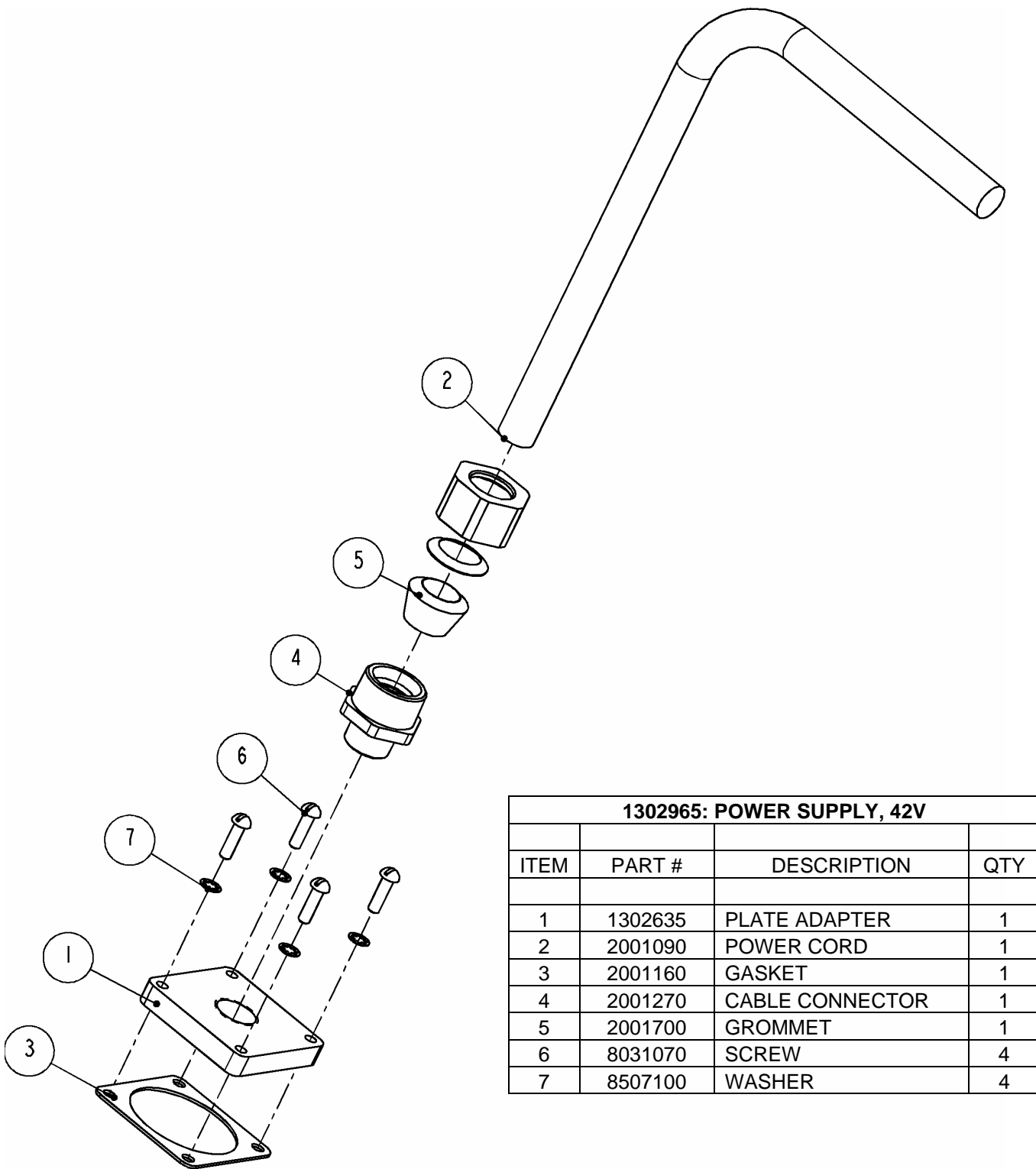
**Figure 13 2007040: CORD AND PLUG ASSEMBLY (14/7)**



<b>2001180: TRIPLOC PLUG, 8 WIRE</b>			
ITEM	PART #	DESCRIPTION	QTY
1	2001190	TRIPLOC PLUG SHELL	1
2	2001230	FEMALE RECEPTACLE	1

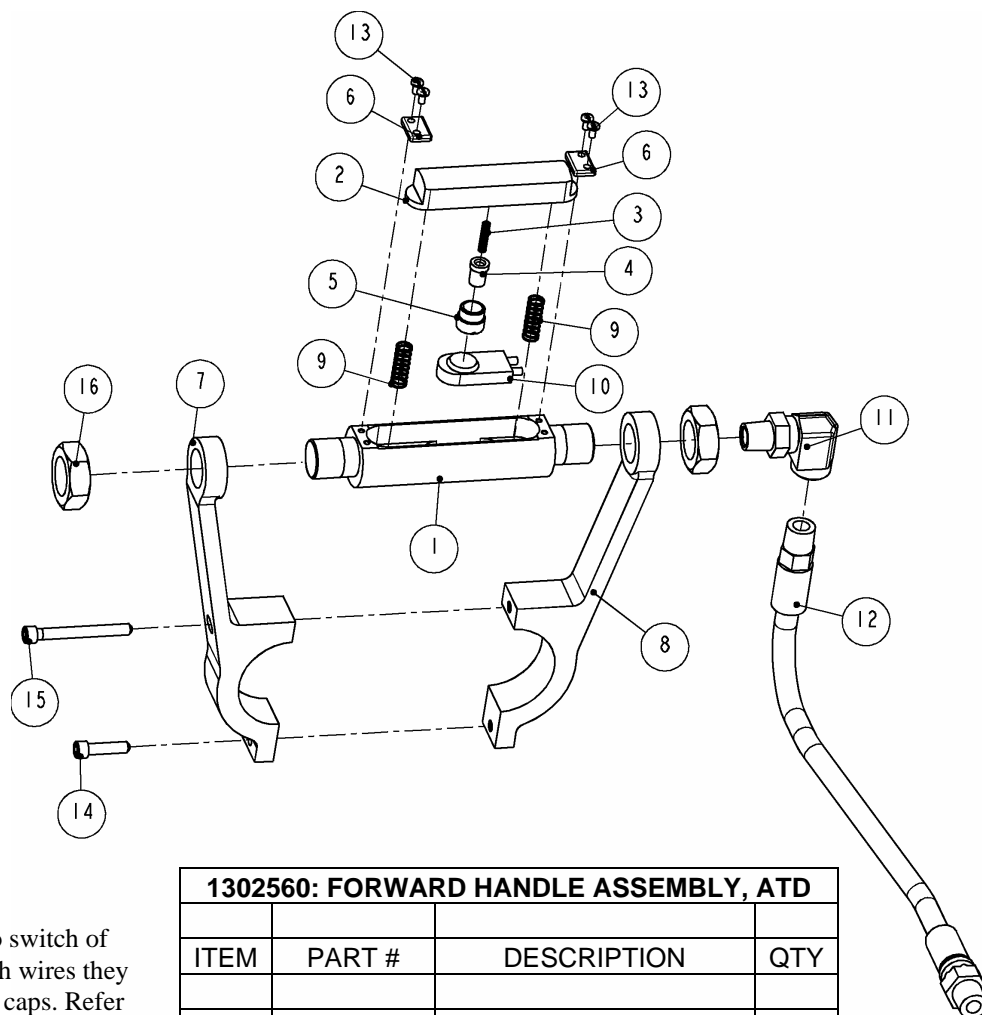
**Figure 14 2001180: TRIPLOC PLUG, 8 WIRE**

**POWER SUPPLY FOR 42V MODELS WITH ATD**



1302965: POWER SUPPLY, 42V			
ITEM	PART #	DESCRIPTION	QTY
1	1302635	PLATE ADAPTER	1
2	2001090	POWER CORD	1
3	2001160	GASKET	1
4	2001270	CABLE CONNECTOR	1
5	2001700	GROMMET	1
6	8031070	SCREW	4
7	8507100	WASHER	4

**Figure 15 1302965: POWER SUPPLY, 42V, ATD**

**HANDLES****FRONT HANDLE, ATD****HANDLE DISASSEMBLY:**

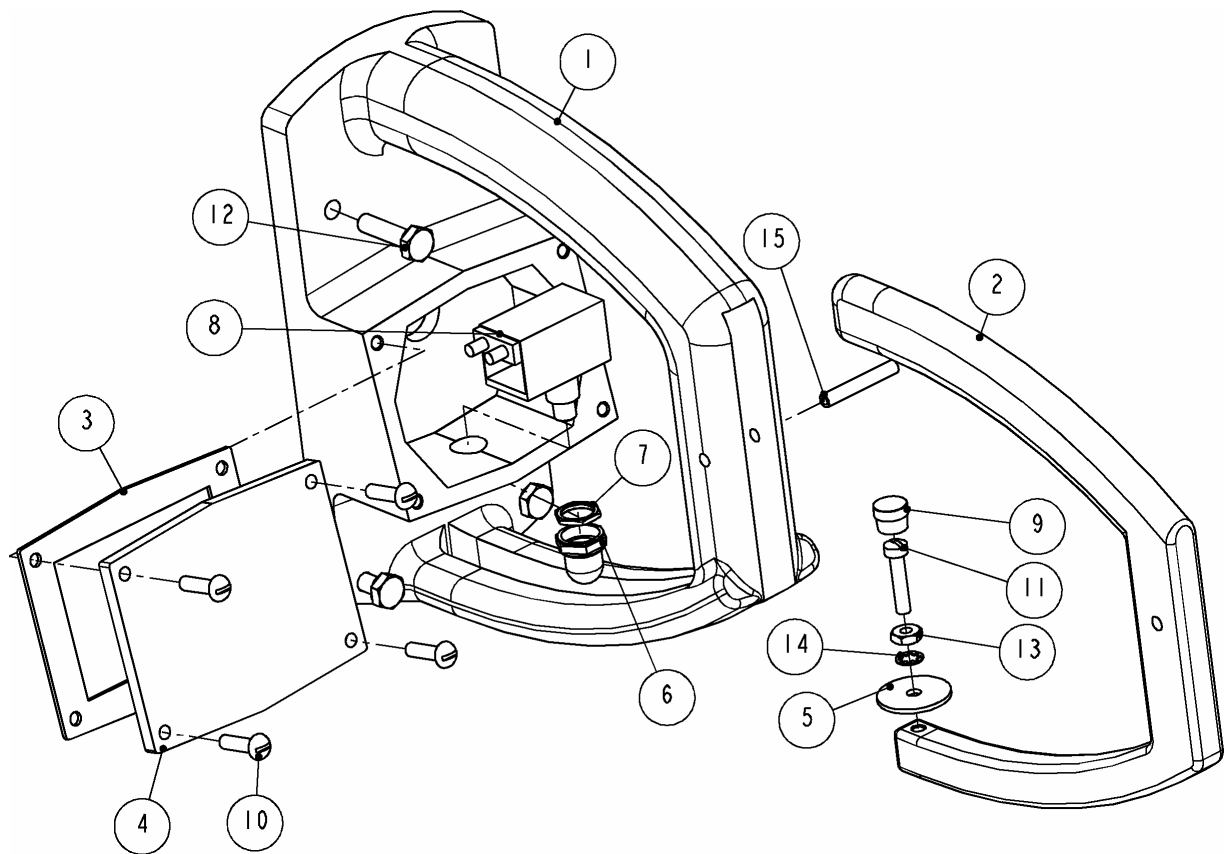
1. In the wirebox identify wires to switch of handle assembly. Identify which wires they connect with prior to removing caps. Refer to wiring diagram.
2. Pull out switch (Item 10, Fig. 16).
3. The drilled hole in the housing (item 1) has been filled with silicon to help keep moisture out of electrical system. Remove silicon prior to reassembly.

**HANDLE REASSEMBLY:**

1. Reverse steps 1 and 2 of "Handle disassembly".
2. After installing switch, fill drilled hole that switch wires were sent thru with silicon. This helps keep moisture out of electrical system.
3. Insert closed end of spring (item 3) into plunger (item 4).

<b>1302560: FORWARD HANDLE ASSEMBLY, ATD</b>			
ITEM	PART #	DESCRIPTION	QTY
1	1302420	HANDLE	1
2	1302430	TRIGGER	1
3	1302440	SPRING	1
4	1302450	PLUNGER	1
5	1302460	HOLDER, PLUNGER	1
6	1302470	HOLDER	2
7	1302480	HANDLE BAR, FRONT	1
8	1302490	HANDLE BAR, REAR	1
9	1701550	SPRING	2
10	2000690	SWITCH	1
11	7018750	ELBOW	1
12	7310120	HOSE, ARMORED	1
13	8086020	SCREW	4
14	8211080	SCREW	1
15	8211180	SCREW	1
16	8500580	NUT	2

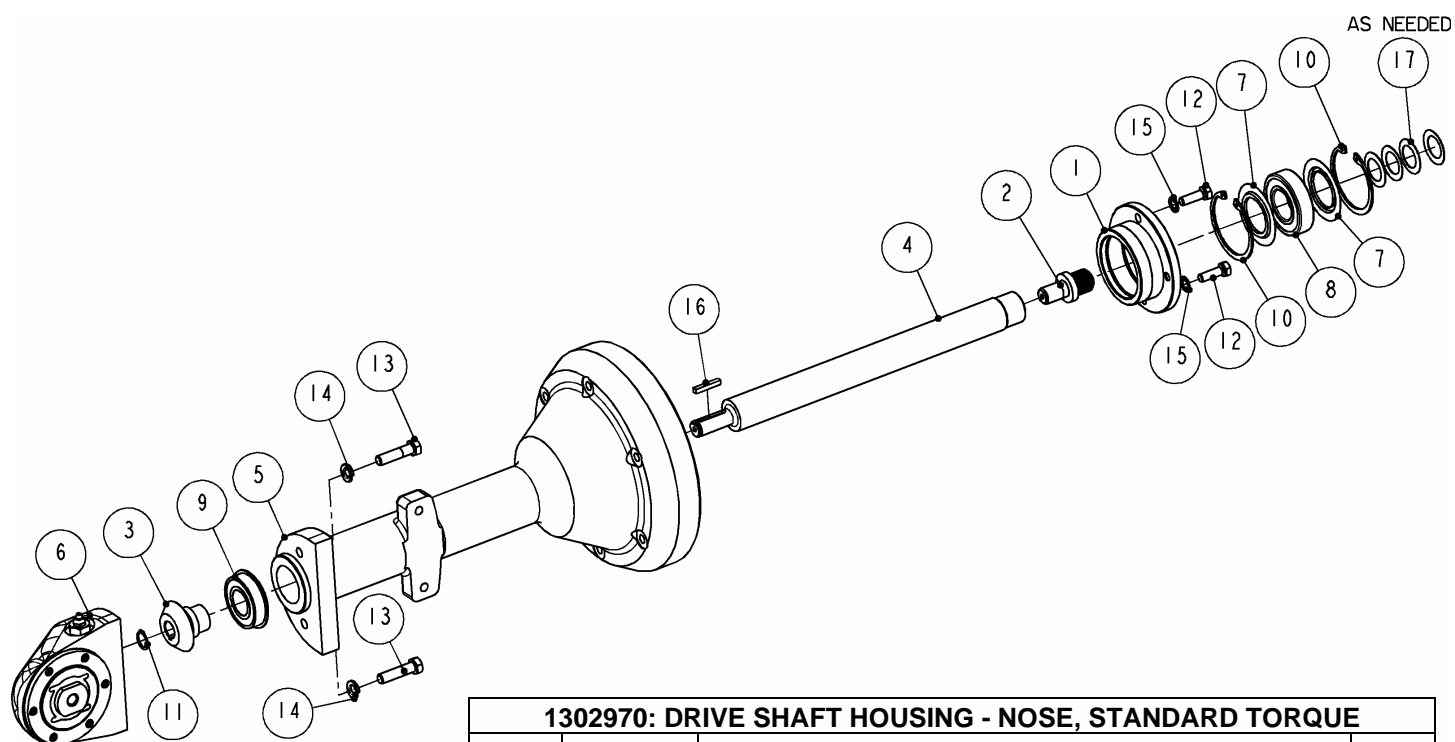
**Figure 16 1302560: FORWARD HANDLE ASSEMBLY, ATD**

**REAR HANDLE, ATD**

<b>1302550: REAR HANDLE ASSEMBLY, ATD</b>			
ITEM	PART #	DESCRIPTION	QTY
1	1302220	HANDLE - REAR	1
2	1302230	TRIGGER, REAR HANDLE	1
3	1302260	GASKET	1
4	1302270	COVER	1
5	1302290	WASHER	1
6	2000020	BOOT, PUSH BUTTON	1
7	2000080	LOCKNUT	1
8	2000700	SWITCH	1
9	7018400	CAP, LUBE FITTING	1
10	8030060	SCREW	4
11	8070070	SCREW	1
12	8411080	SCREW	4
13	8500100	NUT	1
14	8507090	WASHER	1
15	8613200	PIN	1

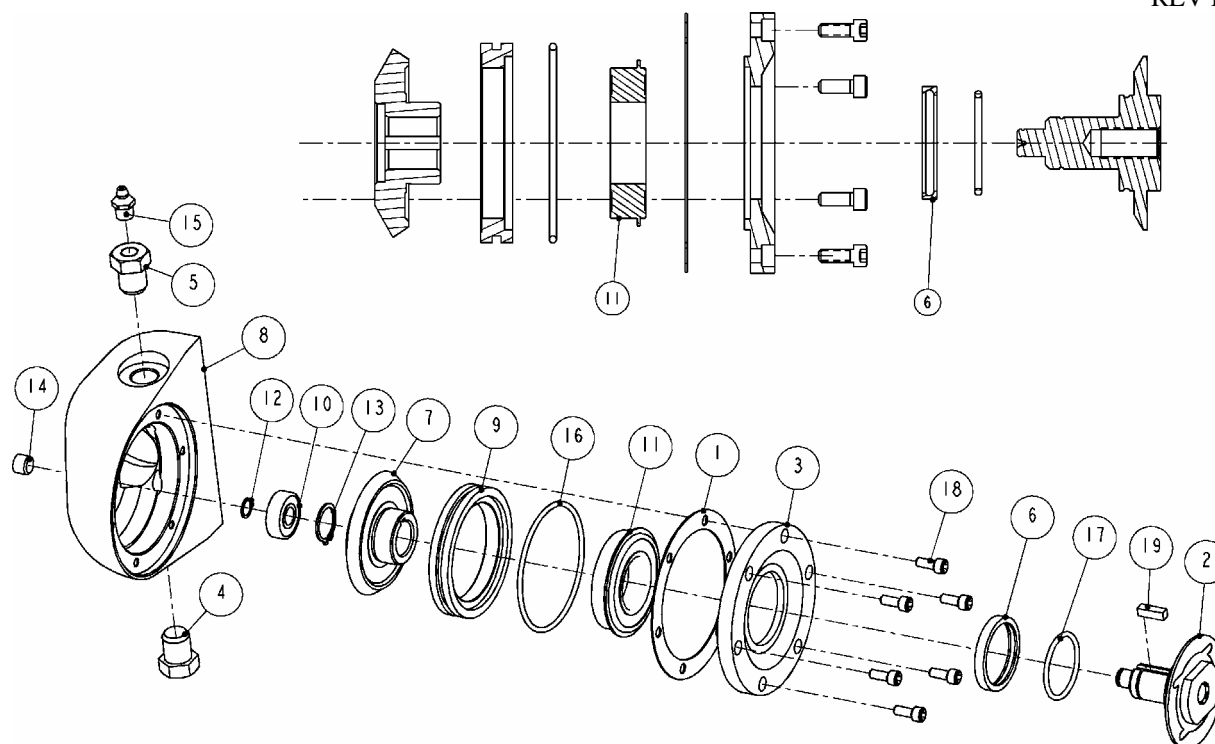
**Figure 17 1302550: REAR HANDLE ASSEMBLY, ATD**



**DRIVESHAFT HOUSING – NOSE ASSEMBLY****STANDARD TORQUE**

<b>1302970: DRIVE SHAFT HOUSING - NOSE, STANDARD TORQUE</b>			
ITEM	PART #	DESCRIPTION	QTY
1	1300350	SLEEVE - DRIVE SHAFT	1
2	1300390	SPLINE BOLT - DRIVE	1
3	<b>1302360</b>	<b>PINION, STANDARD TORQUE</b>	1
4	1302380	SHAFT	1
5	1302510	DRIVE HOUSING	1
6	<b>1302530</b>	<b>SAW MANDREL NOSE ASSEMBLY, STANDARD</b>	1
7	3002560	RING	2
8	3204060	BEARING	1
9	3214050	BEARING	1
10	5002440	RETAINING RING	2
11	5100620	RETAINING RING	1
12	8413080	SCREW	2
13	8415120	SCREW	2
14	8506160	WASHER	2
15	8507150	WASHER	2
16	8603090	SQUARE KEY	1
17	8712020	SPRING WASHER, AS NEEDED	4

**Figure 18 1302970: DRIVE SHAFT HOUSING – NOSE, STANDARD TORQUE**

**STANDARD TORQUE GEAR SET:**

1302360 – BEVEL PINION GEAR (SEE 1302970)

1302370 – BEVEL GEAR (SEE NOSE 1302530)

BLADE: 1100 RPM

**NOSE DISASSEMBLY:**

1. Remove six screws (Item 18).
2. Using a 3/16" hex wrench, remove plug (Item 14)
3. With a center punch inserted thru back of nose (Item 8), press out mandrel (Item 2). All internal parts should come out at this time.

**NOSE REASSEMBLY:**

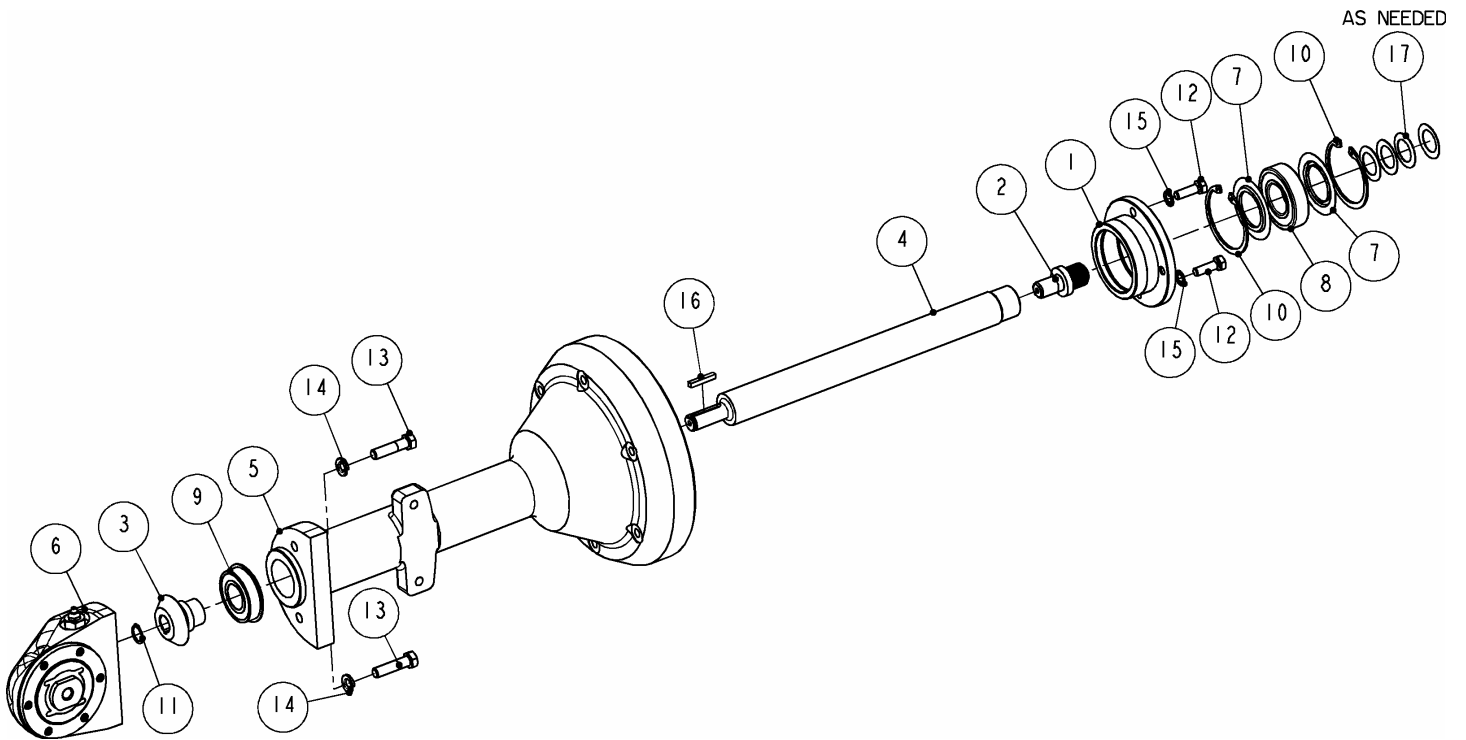
1. Reassemble all parts in reverse order.
2. Refer to Fig. 19 for proper assembly orientation of ring and bearing (Items 6 and Item 11).

**1302530: SAW MANDREL NOSE ASSEMBLY, STANDARD**

ITEM	PART #	DESCRIPTION	QTY
1	1001780	GASKET	1
2	1300190	SAW MANDREL	1
3	1300200	COVER	1
4	1301580	PLUG	1
5	1301590	LUBE PLUG	1
6	1301620	RING	1
7	<b>1302370</b>	<b>BEVEL GEAR, STANDARD</b>	1
8	1302390	NOSE - SAW MANDREL	1
9	1302520	COLLAR BEARING	1
10	3124000	BEARING	1
11	3134060	BEARING	1
12	5100390	RETAINING RING	1
13	5100750	RETAINING RING	1
14	7000010	PLUG	1
15	7016100	LUBE FITTING	1
16	7681470	O-RING	1
17	7701250	O-RING	1
18	8209040	SCREW	6
19	8603050	SQUARE KEY	1

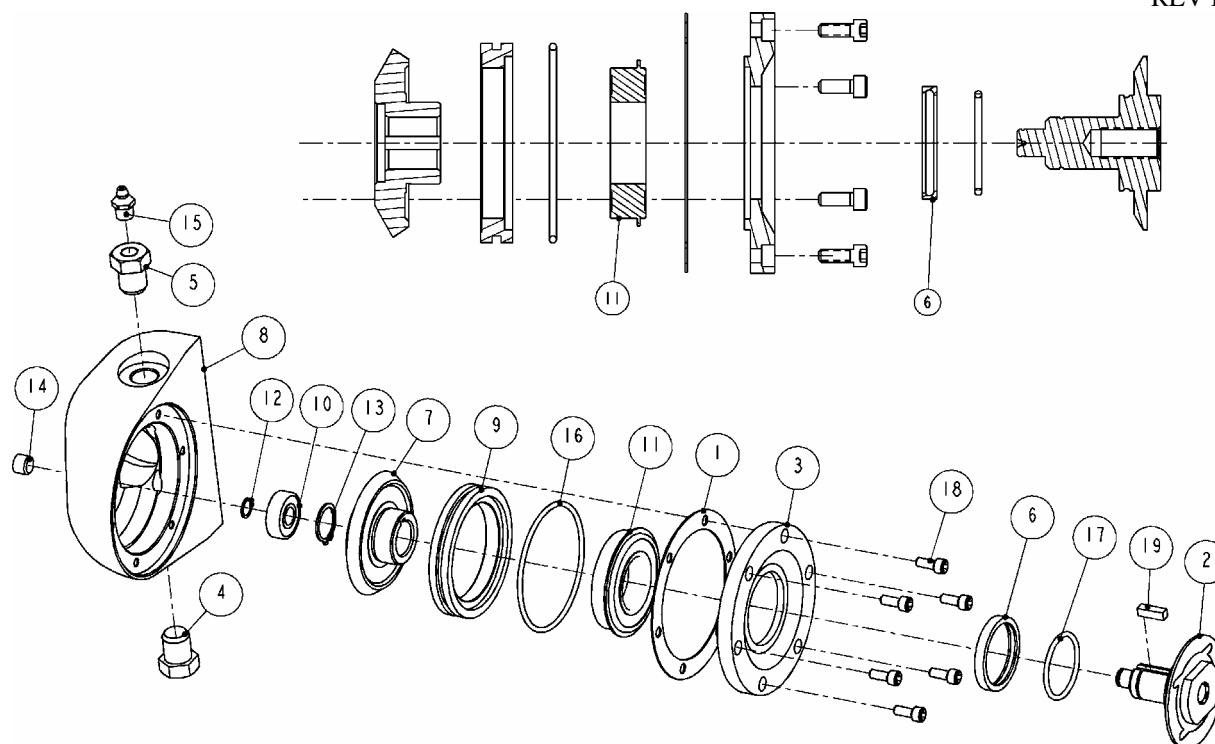
**Figure 19 1302530: NOSE ASSEMBLY, STANDARD TORQUE**

**HIGH TORQUE**



1302552: DRIVE SHAFT HOUSING - NOSE, HIGH TORQUE			
ITEM	PART #	DESCRIPTION	QTY
1	1300350	SLEEVE - DRIVE SHAFT	1
2	1300390	SPLINE BOLT - DRIVE	1
3	<b>1302610</b>	<b>PINION, HIGH TORQUE</b>	1
4	1302380	SHAFT	1
5	1302510	DRIVE HOUSING	1
6	<b>1302531</b>	<b>SAW MANDREL NOSE ASSEMBLY, HIGH TORQUE</b>	1
7	3002560	RING	2
8	3204060	BEARING	1
9	3214050	BEARING	1
10	5002440	RETAINING RING	2
11	5100620	RETAINING RING	1
12	8413080	SCREW	2
13	8415120	SCREW	2
14	8506160	WASHER	2
15	8507150	WASHER	2
16	8603090	SQUARE KEY	1
17	8712020	SPRING WASHER, AS NEEDED	4

**Figure 20 1302552: DRIVE SHAFT HOUSING - NOSE, HIGH TORQUE**

**HIGH TORQUE GEAR SET:**

1302610 – BEVEL PINION GEAR (SEE 1302552)

1302600 – BEVEL GEAR (SEE NOSE 1302531)

BLADE: 1000 RPM

**NOSE DISASSEMBLY:**

4. Remove six screws (Item 18).
5. Using a 3/16" hex wrench, remove plug (Item 14)
6. With a center punch inserted thru back of nose (Item 8), press out mandrel (Item 2). All internal parts should come out at this time.

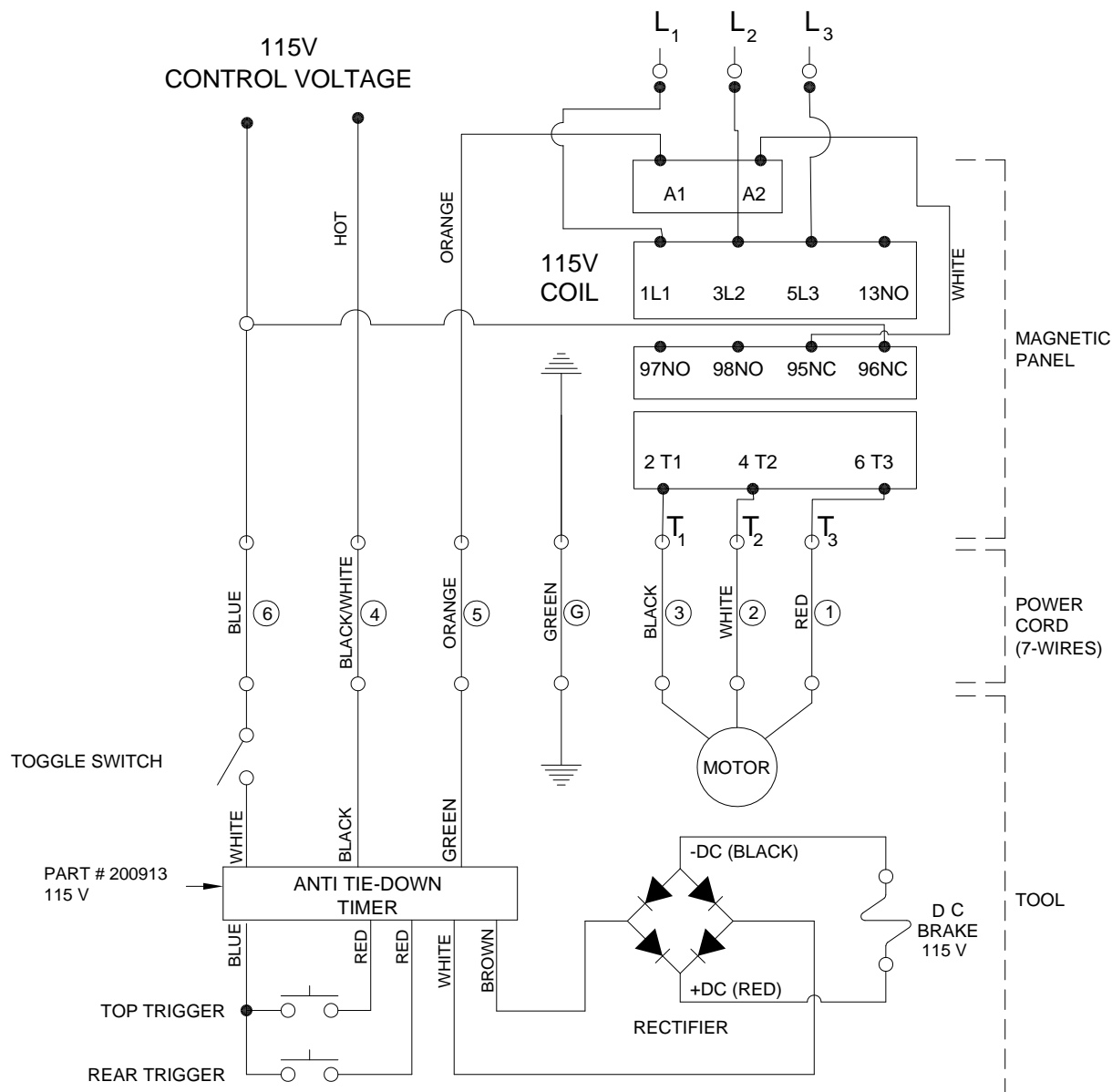
**NOSE REASSEMBLY:**

3. Reassemble all parts in reverse order.
4. Refer to Fig. 21 for proper assembly orientation of ring and bearing (Items 6 and Item 11).

**1302531: SAW MANDREL NOSE ASSEMBLY, HIGH TORQUE**

ITEM	PART #	DESCRIPTION	QTY
1	1001780	GASKET	1
2	1300190	SAW MANDREL	1
3	1300200	COVER	1
4	1301580	PLUG	1
5	1301590	LUBE PLUG	1
6	1301620	RING	1
7	<b>1302600</b>	<b>BEVEL GEAR, HIGH TORQUE</b>	1
8	1302390	NOSE - SAW MANDREL	1
9	1302520	COLLAR BEARING	1
10	3124000	BEARING	1
11	3134060	BEARING	1
12	5100390	RETAINING RING	1
13	5100750	RETAINING RING	1
14	7000010	PLUG	1
15	7016100	LUBE FITTING	1
16	7681470	O-RING	1
17	7701250	O-RING	1
18	8209040	SCREW	6
19	8603050	SQUARE KEY	1

**Figure 21 1302531: NOSE ASSEMBLY – HIGH TORQUE**

**WIRING DIAGRAM**

1. DO NOT ATTEMPT OR MAKE REPAIRS ON THE MACHINE WHILE POWER IS ON.
2. ALL ELECTRICAL WORK MUST BE PERFORMED BY A QUALIFIED ELECTRICIAN.
3. THE ELECTRICAL DIAGRAM SHOWS THE MACHINE IN THE "OFF" POSITION.
4. THE MAGNETIC STRATER COIL MUST OPERATE AT SAME VOLTAGE AS THE BRAKE. BRAKE VOLTAGE IS 110V OR 42V.
5. PRIMARY SIDE OF TRANSFORMER SHOULD ALWAYS COME FROM THE SAME SOURCE AS THE POWER FOR THE MAGNETIC STARTER COILS.

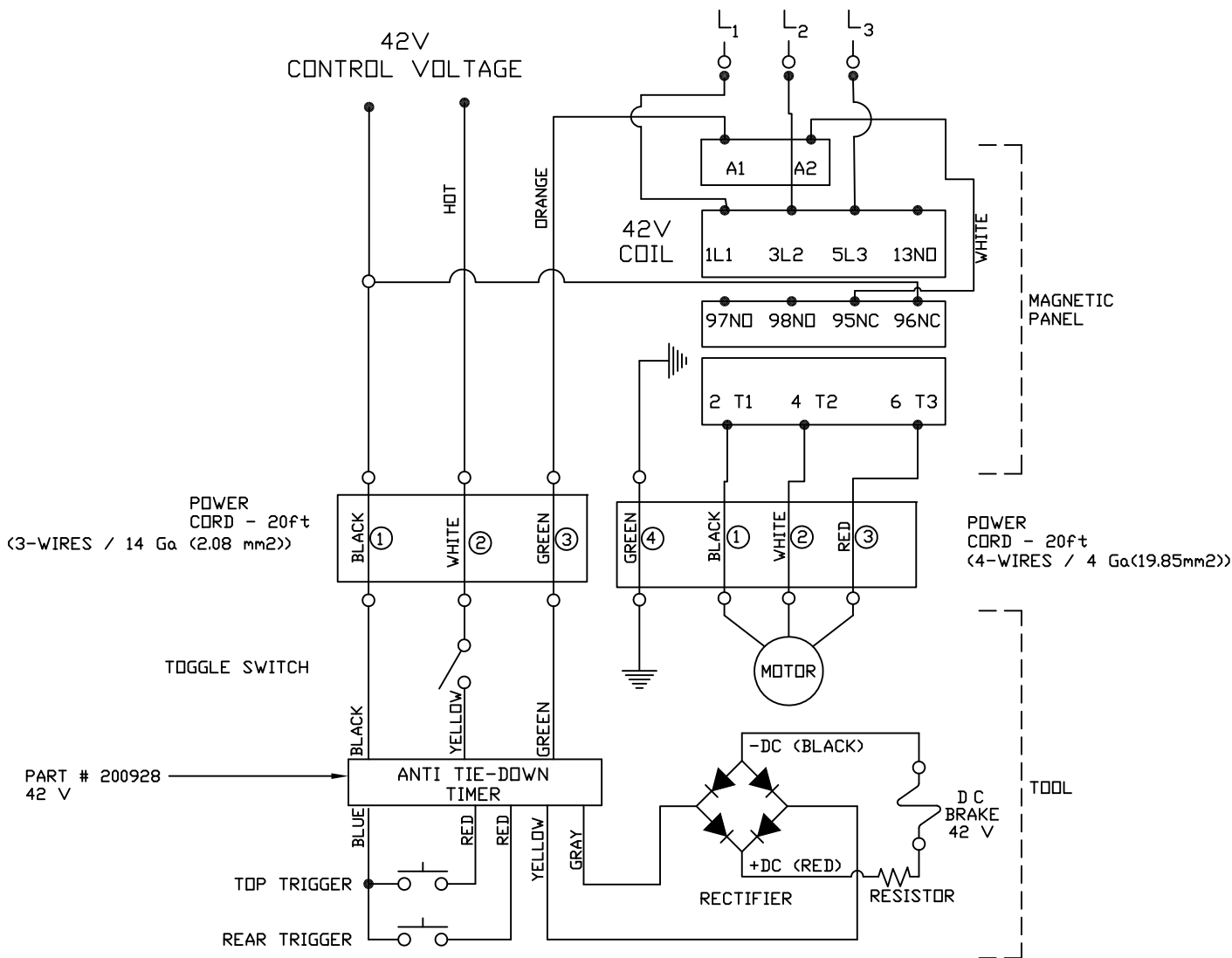
**To obtain the correct Kentmaster part number for 3-pole contactor and overload relay, please contact the Kentmaster representative.**

**Figure 22 WIRING DIAGRAM FOR JB with ATD**

# KENTMASTER MFG., CO., INC.

1801 S. MOUNTAIN AVE. MONROVIA, CA 91016

## KENTMASTER HOG SPLITTING SAW , -JB-A - 42V



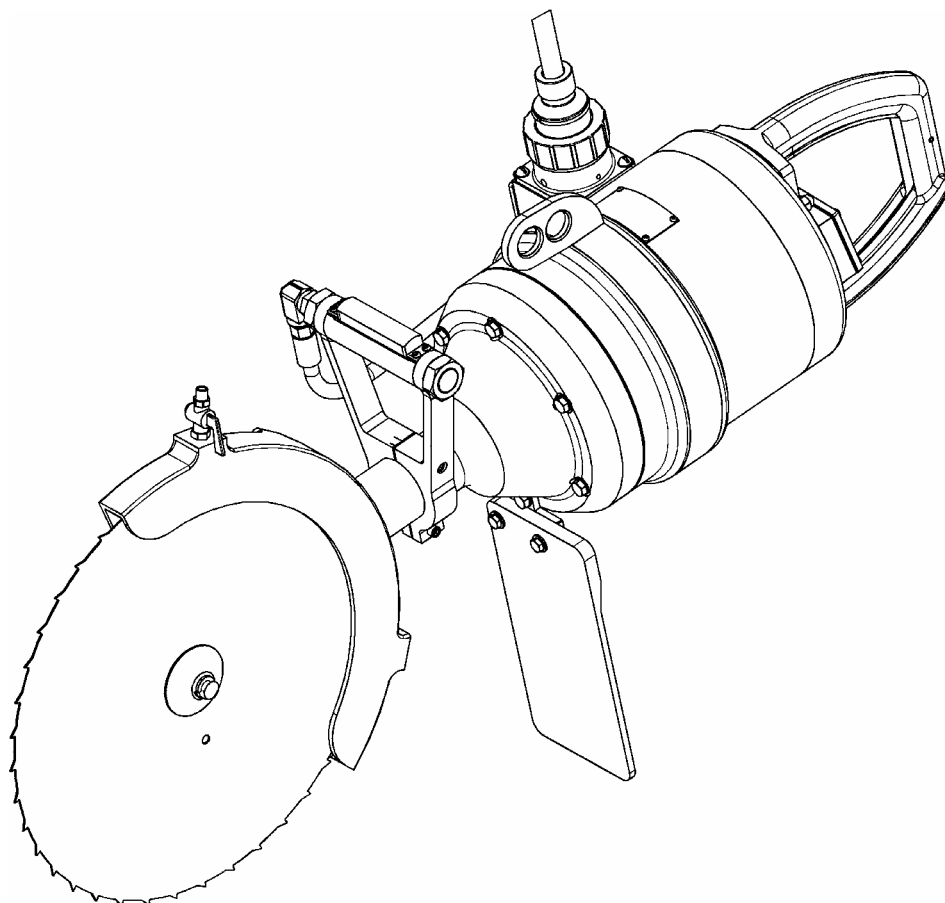
ELECTRICAL DIAGRAM

NOTES :

1. ALL ELECTRICAL WORK MUST BE PERFORMED BY A QUALIFIED ELECTRICIAN.
2. DO NOT ATTEMPT OR MAKE REPAIRS ON THE MACHINE WHILE POWER IS ON.
3. THE ELECTRICAL DIAGRAM SHOWS THE MACHINE IN THE "OFF" POSITION.
4. POWER CORD 4/4:
  - WIRE #1 (BLACK): THREE PHASE POWER CORD CONNECTED DIRECTLY TO MOTOR.
  - WIRE #2 (WHITE): THREE PHASE POWER CORD CONNECTED DIRECTLY TO MOTOR.
  - WIRE #3 (RED): THREE PHASE POWER CORD CONNECTED DIRECTLY TO MOTOR.
  - WIRE #4 (GREEN): GROUND WIRE, CONNECTED TO SAW FRAME.
4. POWER CORD 3/14:
  - WIRE #3 (GREEN): CONNECTED TO THE TIMER GREEN WIRE AT THE TOOL.
  - WIRE #2 (WHITE): CONNECTED TO TOGGLE SWITCH AT THE TOOL.
  - WIRE #1 (BLACK): CONNECTED TO THE TIMER BLACK WIRE AT THE TOOL.
5. ALL WIRES OF THE ANTI TIE-DOWN TIMER THAT ARE NOT USED MUST BE TAPED INDIVIDUALLY.

[ENGLISH]

## GENERAL INFORMATION



### MODEL

## **“160-JB-A” HOG SPLITTING SAW WITH ANTI-TIE DOWN**

---

### SERVICE CENTERS

**KENTMASTER LTD. (U.K)**  
16 AVONBANK INDUSTRIAL CENTRE  
WEST TOWN ROAD  
AVONMOUTH - BRISTOL BS11 9DE  
UNITED KINGDOM

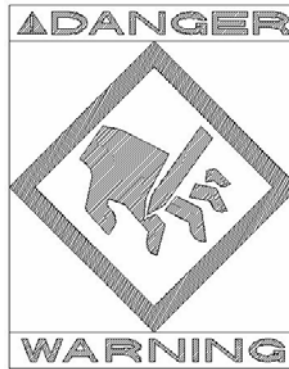
☎ TELEPHONE: ++ 44- (0) 117- 9235035  
FAX: ++ 44- (0) 117- 9829010

**KENTMASTER MFG. CO., INC.**  
1801 SOUTH MOUNTAIN AVE.  
MONROVIA, CALIFORNIA 91016  
UNITED STATES OF AMERICA

☎ TELEPHONE: (626) 359-8888  
FAX: (626) 303-5151

**NOTICE TO EMPLOYER AND PURCHASER OF TOOL**  
**NOTICE TO SAFETY DIRECTOR**

**You have purchased a powerful tool that, if misused, can cause severe injury and harm to your employees. You must instruct your employees in the safe and proper use of this tool and to follow the safety procedures and instructions that have been supplied by the manufacturer of this tool. Please follow the following instructions.**



1. Instruct tool operators to test the tool each day before using it to be sure it does not malfunction. Remove and repair any tool that malfunctions.
2. Instruct tool operators to immediately stop using a tool that malfunctions or is defective.
3. Instruct personnel to immediately remove all tools that malfunction. Be sure to disconnect tool from power supply.
4. Instruct all personnel to stay clear of tool, and not to stand or walk in front of, or next to tool when in use.
5. Point out to all personnel the dangers related to the misuse of tool and the importance of following safety procedures and instructions.
6. Do not make, or allow others to make, alterations or modifications to this tool. Replace all lost or illegible labels.
7. Follow all safety, installation and maintenance instructions provided with this tool. Establish proper safety procedures in accordance with local and national requirements to prevent accidental energizing of tool that can cause injuries.
8. If this tool is sold or change in ownership takes place, you must provide the new owner all safety instructions, notices and maintenance instructions you were originally provided. You can obtain additional copies of the instructions from Kentmaster, free of charge upon request.
9. Give copies of instructions to:
  - (A) Tool Operators**
  - (B) Maintenance Supervisor**
  - (C) Clean-up Supervisor**




## GENERAL INFORMATION


COVERING: SAFETY PRECAUTIONS AND PLACING INTO SERVICE  
**HOG SPLITTING SAW with ANTI-TIE DOWN**


**READ THIS MANUAL CAREFULLY BEFORE INSTALLING, OPERATING OR SERVICING THIS TOOL**


IT IS THE RESPONSIBILITY OF THE EMPLOYER TO PLACE THIS INFORMATION INTO THE HANDS OF THE OPERATOR.


### **PLACING INTO SERVICE**

 **WARNING** = Hazards or unsafe practices which could result in severe personal injury, death or substantial property damage.

 **CAUTION** = Hazards or unsafe practices which could result in minor personal injury, product or property damage.

 **NOTICE** = Important installation, operation or maintenance information.

 **WARNING** Installation, adjustment repair and maintenance of this tool must be made by trained and qualified personnel.

 **WARNING** Always disconnect power supply from tool before:  
(A) Installing or removing blade from tool.  
(B) Making repairs or adjustments to the tool.  
(C) performing maintenance or cleanup work.

**DECLARATION OF CONFORMITY**

**DECLARATION OF CONFORMITY**

DECLARATION DE CONFORMITE -DECLARACION DE CONFORMIDAD- ERKLARUNG BEZUGLICH EINHALTUNG DER VORSCHRIFTEN  
DICHIARAZIONE DI CONFORMITA . CONFORMITEITSVERKLARING

**MANUFACTURED BY:**

FABRIQUE PAR:  
FABRICADA POR:  
HERGESTELLTVON:  
FABBRICATO DA:  
VERVAARDIGD DOOR:

**KENTMASTER MFG CO., INC.**  
**1801 SOUTH MOUNTAIN AVE.**  
**MONROVIA, CALIFORNIA 91016**  
**UNITED STATES OF AMERICA**  
**TELEPHONE (626) 359-8888 FAX (626) 303-5151**

**TYPE / SERIES: HOG SPLITTING SAW with ANTI-TIE DOWN**

TYPE / SERIE:  
TIPO / SERIE:  
TYP / SERIE:  
TIPO / SERIE:  
TYPE / SERIE:

**MODEL: 160-JB-A**

MODELE:  
MODELO:  
MODELL:  
MODELLO:  
MODEL:

**SERIAL NO. RANGE: XXXXX**

N SERIE: • GAMA DE No. DE SERIE: • SERIEN-NR.-BEREICH: • NUMERI DI SERIE: • SERIENUMMERS:

**This product complies with the following European Community Directives:**

Ce produit est conforme aux directives de la Communauté européenne suivantes:  
Este producto cumple con las siguientes Directrices de la Comunidad Europea:  
Dieses Produkt erfüllt die folgenden Vorschriften der Europäischen Gemeinschaft:  
Questo prodotto è conforme alle seguenti direttive CEE:  
Dit produkt voldoet aan de volgende EG-richtlijnen:

**2004/108/EC, 2006/95/EC, 2006/42/EC**

**The following Standards were used to verify compliance with the Directives:**

Les normes suivantes ont été utilisées pour vérifier la conformité avec les Directives:  
Las siguientes Normas se usaron para verificar el cumplimiento de las Directrices:  
Folgende Normen wurden angewandt, um Erfüllung der Vorschriften zu bestätigen:  
Per verificare la conformità del prodotto alle direttive sono stati usati i seguenti standard:  
De volgende normen zijn gebruikt om naleving van de richtlijnen te bevestigen:

**EN 12984**

**Approved by:** \_\_\_\_\_

**Date:** JAN-1-2010

RALPH KARUBIAN MONROVIA, CA. U.S.A.  
(Engineering Manager) (Directeur technique) (gerente de ingenieria) (verantwortlicher Konstruktionsleiter) (Responsabile tecnico) (ondersteunend technisch mangar)

## Kentmaster Worldwide Location

Kentmaster Equipment (Aust) PTY.LTD.

Unit 2,24 Central Court  
Browns Plains Qld. 4118  
Australia

Telephone: (07) 3806-8400

Fax: (07) 3806-7933

[Australia@Kentmaster.com](mailto:Australia@Kentmaster.com)

---

Kentmaster do Brasil, Ltda.

Av. Dr. Joao Teodoro No. 805  
Bairro De Vila Rezende  
13405-240 Piracicaba, SP,  
Brazil

Telephone #1: (019) 3 413 3113

Telephone #2: (019)983-4973

Fax: (019) 3 413 3113

[Brazil@Kentmaster.com](mailto:Brazil@Kentmaster.com)

---

Kentmaster (IRL) LTD.

Benamore, Dublin Road.  
Roscrea,  
CO, Tipperary,  
Ireland

Telephone: (353) 0505-23292

Fax: (353) 0505-23299

[Ireland@Kentmaster.com](mailto:Ireland@Kentmaster.com)

---

Kentmaster Equipment (NZ) LTD.

5 Cooper Street  
Havelock North  
New Zealand

Telephone #1: (64) 6 8777 857

Telephone #2: 0800 KENTMASTER

Fax: (64) 6 8777 858

[NewZealand@Kentmaster.com](mailto:NewZealand@Kentmaster.com)

---

Kentmaster South Africa (PTY) LTD.

Johannesburg - S. Africa  
Unit 54 Sunnyrock Park  
Sunrock Close, Germiston  
South Africa

Telephone: (27) 11-455-3748

Fax: (27) 11-455-3749

[SouthAfrica@Kentmaster.com](mailto:SouthAfrica@Kentmaster.com)

---

Kentmaster (UK ) LTD.

Unit 16 Avonbank Ind. Centre  
West Town Rd, Avonmouth-Bristol,  
BS11 9DE  
England

Telephone: (44) 117-923-5035

Fax: (44)-117-932-9010

[UK@Kentmaster.com](mailto:UK@Kentmaster.com)

---

Kentmaster Mfg. Co., Inc.

1801 South Mountain Ave.  
Monrovia, CA, 91016  
USA

Telephone #1: (626) 359-8888

Telephone #2: (800) 421-1477

Fax: (626) 303-5151

[info@Kentmaster.com](mailto:info@Kentmaster.com)

---

Kentmaster Omaha

4417 South 139th Street  
Omaha, NE, 68137  
USA

Telephone #1: (402) 896-3355

Telephone #2: (800) 367-3181

Fax: (402) 896-3311

[Omaha@Kentmaster.com](mailto:Omaha@Kentmaster.com)

---

**INDEX**

<b>OPERATING AND SAFETY INSTRUCTIONS</b> .....	<b>2</b>
<b>OPERATING INSTRUCTIONS</b> .....	<b>3</b>
<b>MAINTENANCE</b> .....	<b>3</b>
<b>BLADE REMOVAL AND CLEANING</b> .....	<b>3</b>
<b>TROUBLE SHOOTING</b> .....	<b>3</b>
<b>SERVICE</b> .....	<b>4</b>
<b>PARTS BOOK</b> .....	<b>5</b>
<b>160-JB-A</b> .....	<b>5</b>
<b>ELECTRO-MAGNETIC BRAKE</b> .....	<b>7</b>
BRAKE ADJUSTMENT .....	9
<b>MOTOR ASSEMBLY, 3HP</b> .....	<b>9</b>
MOTOR DISASSEMBLY AND REASSEMBLY PROCEDURE.....	11
<b>POWER SUPPLY</b> .....	<b>12</b>
POWER SUPPLY FOR NON 42V MODELS WITH ATD .....	12
POWER SUPPLY FOR 42V MODELS WITH ATD .....	14
<b>HANDLES</b> .....	<b>15</b>
FRONT HANDLE, ATD.....	15
REAR HANDLE, ATD .....	16
<b>DRIVESHAFT HOUSING – NOSE ASSEMBLY</b> .....	<b>17</b>
STANDARD TORQUE .....	17
HIGH TORQUE .....	19
<b>WIRING DIAGRAM</b> .....	<b>21</b>
<b>GENERAL INFORMATION</b> .....	<b>24</b>
<b>DECLARATION OF CONFORMITY</b> .....	<b>25</b>
<b>Kentmaster Worldwide Location</b> .....	<b>26</b>
<b>INDEX</b> .....	<b>27</b>
<b>FIGURES - INDEX</b> .....	<b>28</b>

**FIGURES - INDEX**

Figure 1 MODEL 160 – BLADE REPLACEMENT .....	4
Figure 2 MODEL “160-JB-A” – MAIN ASSEMBLY .....	5
Figure 3 BOM FOR MODEL “160-JB-A” .....	6
Figure 4 2000201: ELECTRO-MAGNETIC BRAKE, 90VDC.....	7
Figure 5 2000350: ELECTRO-MAGNETIC BRAKE, 42VDC.....	7
Figure 6 2000200: ARMATURE ASSEMBLY .....	8
Figure 7 BRAKE ADJUSTMENT .....	8
Figure 8 3HP MOTOR ASSEMBLY .....	9
Figure 9 BOM FOR 3HP MOTOR ASSEMBLY .....	10
Figure 10 ROTOR ASSEMBLY, 3HP .....	11
Figure 11 1302950: POWER SUPPLY, NON 42V, ATD .....	12
Figure 12 2001140: WATERPROOF RECEPTACLE, 8 WIRE .....	12
Figure 13 2007040: CORD AND PLUG ASSEMBLY (14/7).....	13
Figure 14 2001180: TRIPLOC PLUG, 8 WIRE.....	13
Figure 15 1302965: POWER SUPPLY, 42V, ATD .....	14
Figure 16 1302560: FORWARD HANDLE ASSEMBLY, ATD .....	15
Figure 17 1302550: REAR HANDLE ASSEMBLY, ATD .....	16
Figure 18 1302970: DRIVE SHAFT HOUSING – NOSE, STANDARD TORQUE.....	17
Figure 19 1302530: NOSE ASSEMBLY, STANDARD TORQUE .....	18
Figure 20 1302552: DRIVE SHAFT HOUSING - NOSE, HIGH TORQUE .....	19
Figure 21 1302531: NOSE ASSEMBLY – HIGH TORQUE.....	20
Figure 22 WIRING DIAGRAM FOR JB with ATD.....	21