

OPERATOR'S MANUAL

INCLUDING: OPERATION, INSTRUCTION, INSTALLATION, MAINTENANCE AND PARTSBOOK

IMPORTANT: READ THIS MANUAL CAREFULLY BEFORE INSTALLING, OPERATING OR SERVICING THIS TOOL.

HOG SPLITTING SAW with INVERTER

TOOL DATA

MODEL: 160-JI

ASSEMBLY NO. 1600510 (INCLUDING INVERTER)

1600570 (INVERTER NOT INCLUDED) – INVERTER IS REQUIRED FOR PROPER OPERATION

TYPE: ELECTRICAL OPERATED

NET WEIGHT: 120 LBS (55 KG)

MOTOR HORSEPOWER: 3HP

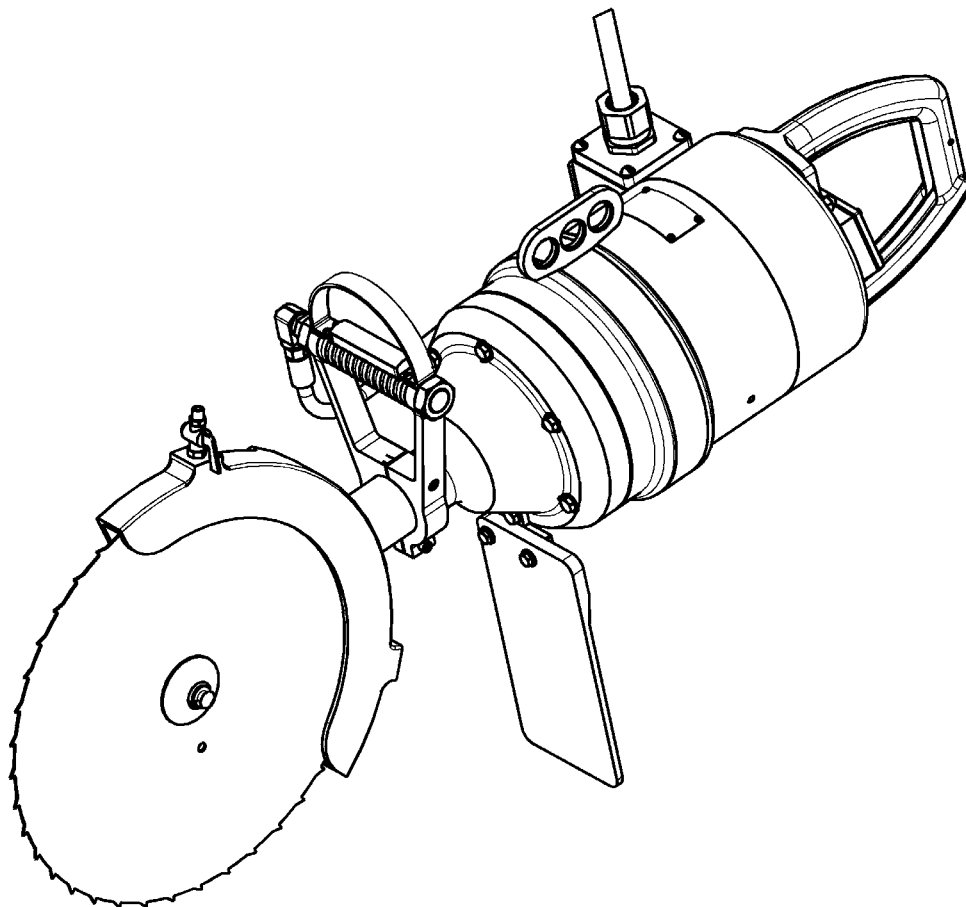

- = Hazards or unsafe practices which could result in severe personal injury, death or substantial property damage.
- = Hazards or unsafe practices which could result in minor personal injury, product or property damage.
- = Important installation, operation or maintenance information.

OPERATING AND SAFETY INSTRUCTIONS

- ⚠ WARNING** DO NOT OPERATE THIS TOOL UNTIL YOU HAVE READ AND UNDERSTOOD THE SAFETY INSTRUCTIONS AND OPERATING MANUALS.
- ⚠ WARNING** DO NOT OPERATE THIS TOOL UNTIL YOU HAVE RECEIVED TRAINING IN THE HANDLING, OPERATION AND USE OF THIS TOOL.
- ⚠ WARNING** STOP USING A MALFUNCTIONING OR DEFECTIVE TOOL IMMEDIATELY. REPORT ANY PROBLEMS OR DEFECTS TO YOUR SUPERVISOR FOR REMOVAL OF THE TOOL FROM SERVICE.
- ⚠ WARNING** DO NOT ATTEMPT TO REPAIR THE TOOL YOURSELF.
- ⚠ WARNING** DO NOT ALLOW UNAUTHORIZED PERSONS TO USE TOOL.
- ⚠ WARNING** REMOVE AND DISCONNECT POWER FROM THE TOOL WHEN TOOL IS LEFT UNATTENDED OR IS NOT IN USE.
- ⚠ WARNING** NEVER TIE DOWN, BYPASS, ALTER OR MODIFY THE ACTIVATING SWITCHES OR TRIGGERS OF THIS TOOL.
- ⚠ WARNING** NEVER MAKE ALTERATIONS OR MODIFICATIONS TO THIS TOOL.
- ⚠ WARNING** BE CONSTANTLY AWARE AND ALERT FOR UNSAFE CONDITIONS AND REPORT THEM IMMEDIATELY TO YOUR SUPERVISOR.
- ⚠ WARNING** NEVER PLACE YOUR HAND OR ANY PART OF YOUR BODY IN THE CUTTING PATH OF THE TOOL.
- ⚠ WARNING** NEVER ALLOW ANYONE ELSE TO PLACE THEIR HANDS OR ANY PART OF THEIR BODY IN THE CUTTING PATH OF THE TOOL.
- ⚠ WARNING** DO NOT ACTIVATE CONTROL SWITCHES OR TRIGGERS OF THIS TOOL UNLESS YOU INTEND TO TEST OR OPERATE THIS TOOL.
- ⚠ WARNING** DO NOT USE THIS TOOL FOR ANY PURPOSE OTHER THAN IT'S INTENDED PURPOSE.
- WHEN OPERATING THIS TOOL WEAR THE PROTECTIVE GEAR AND SAFETY EQUIPMENT SUPPLIED TO YOU.
- ⚠ WARNING** THE NOISE EMISSION (SOUND PRESSURE LEVEL) AT THE WORKSTATION MAY EXCEED 80 dB (A). EAR AND SOUND PROTECTION GEAR IS REQUIRED.

OPERATING INSTRUCTIONS

⚠ WARNING ONLY TRAINED PERSONNEL ARE TO OPERATE THIS TOOL.

1. TO ENSURE TOOL IS OPERATING PROPERLY, PERFORM FOLLOWING STEPS AT START OF EACH SHIFT:
 - MAKE SURE TOOL MOVES UP AND DOWN FREELY WHILE HANGING FROM BALANCER OVERHEAD.
 - WITH POWER TO TOOL TURNED ON, TEST TRIGGER FOR PROPER OPERATION.
 - DEPRESS EACH TRIGGER SEPARATELY. TOOL SHOULD NOT ACTIVATE. DEPRESS BOTH TRIGGERS. TOOL SHOULD ACTIVATE.
 - IF TOOL HAS "ANTI-TIE DOWN" OPTION, BOTH TRIGGERS MUST BE DEPRESSED SIMULTANEOUSLY FOR TOOL TO ACTIVATE.
 - THIS TOOL HAS AN ELECTRIC BRAKE ASSEMBLY (INVERTER BOX) THAT SLOWS DOWN THE BLADE WHEN EITHER TRIGGER IS RELEASED. **INVERTER HAS TO BE INSTALLED WITH 1600510 AND 1600570 MODEL**
2. TO PERFORM WORK, HOLD TOOL FIRMLY AT BOTH HANDLES. SQUEEZE TRIGGERS TO ACTIVATE TOOL.
3. SAW CARCASS THROUGH THE TAILBONE, MOVING DOWNWARD IN A STRAIGHT LINE.
4. DO NOT EXERT EXCESSIVE PRESSURE. ALLOW TIME FOR TOOL TO CUT.
5. CUT DOWNWARD IN A STRAIGHT LINE THROUGH SHOULDER AND NECK OF CARCASS.

MAINTENANCE

⚠ WARNING ONLY TRAINED AND QUALIFIED PERSONNEL ARE TO PERFORM MAINTENANCE AND SERVICE TO THIS TOOL.

THE COMPRESSED AIR DISTRIBUTION SYSTEM MUST BE LARGE ENOUGH TO SUPPLY AN ADEQUATE VOLUME OF CLEAN AND DRY COMPRESSED AIR TO THE TOOL.

TOOL REQUIRES GREASING AFTER EVERY 40 HOURS OF OPERATION. GREASE ONE LOCATION USING KENTMASTER GREASE (PART NO. 7903070).

BLADE REMOVAL AND CLEANING

⚠ WARNING ALWAYS DISCONNECT POWER SUPPLY FROM TOOL BEFORE INSTALLING OR REMOVING BLADE FROM TOOL.

⚠ WARNING ALWAYS WEAR WIRE MESH GLOVES WHEN INSTALLING OR REMOVING BLADE FROM TOOL.

1. REMOVE SCREW (ITEM NO. 1, FIG. NO. 1).
2. REMOVE PARTS (ITEM NO. 2-4, FIG. NO. 1).
3. CLEAN ALL PARTS REMOVED WITH SOAP AND WATER.
4. SHARPEN OR REPLACE BLADES WHEN NECESSARY AND LUBRICATE ALL PARTS.
5. REASSEMBLE IN REVERSE ORDER.

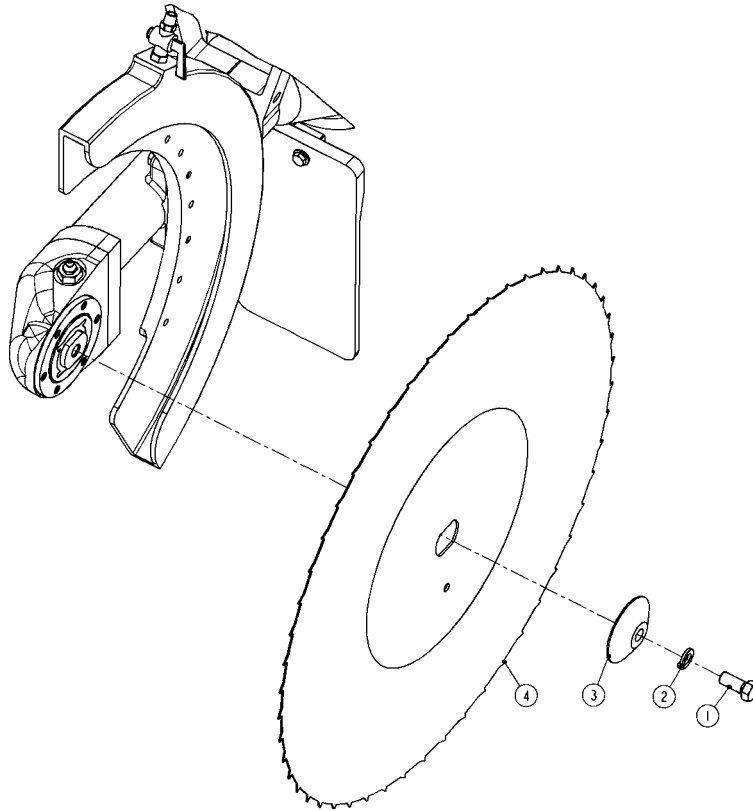
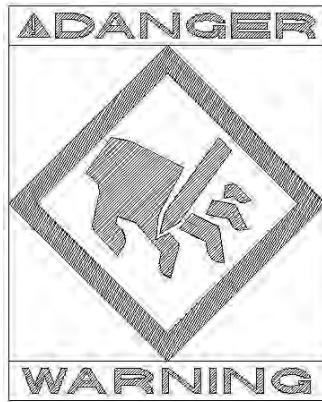

Figure 1 MODEL 160 – BLADE REPLACEMENT

SERVICE

1. KEEP GOOD RECORDS OF ALL SERVICE ACTIVITY AND INCLUDE TOOL IN PREVENTIVE MAINTENANCE PROGRAM.
2. USE ONLY GENUINE KENTMASTER REPLACEMENT PARTS TO ASSURE PROPER PERFORMANCE OF TOOL.
3. CONTACT THE KENTMASTER SUPPLIER NEAREST YOU FOR PARTS AND CUSTOMER SERVICE INFORMATION.



PARTS BOOK
160-JI

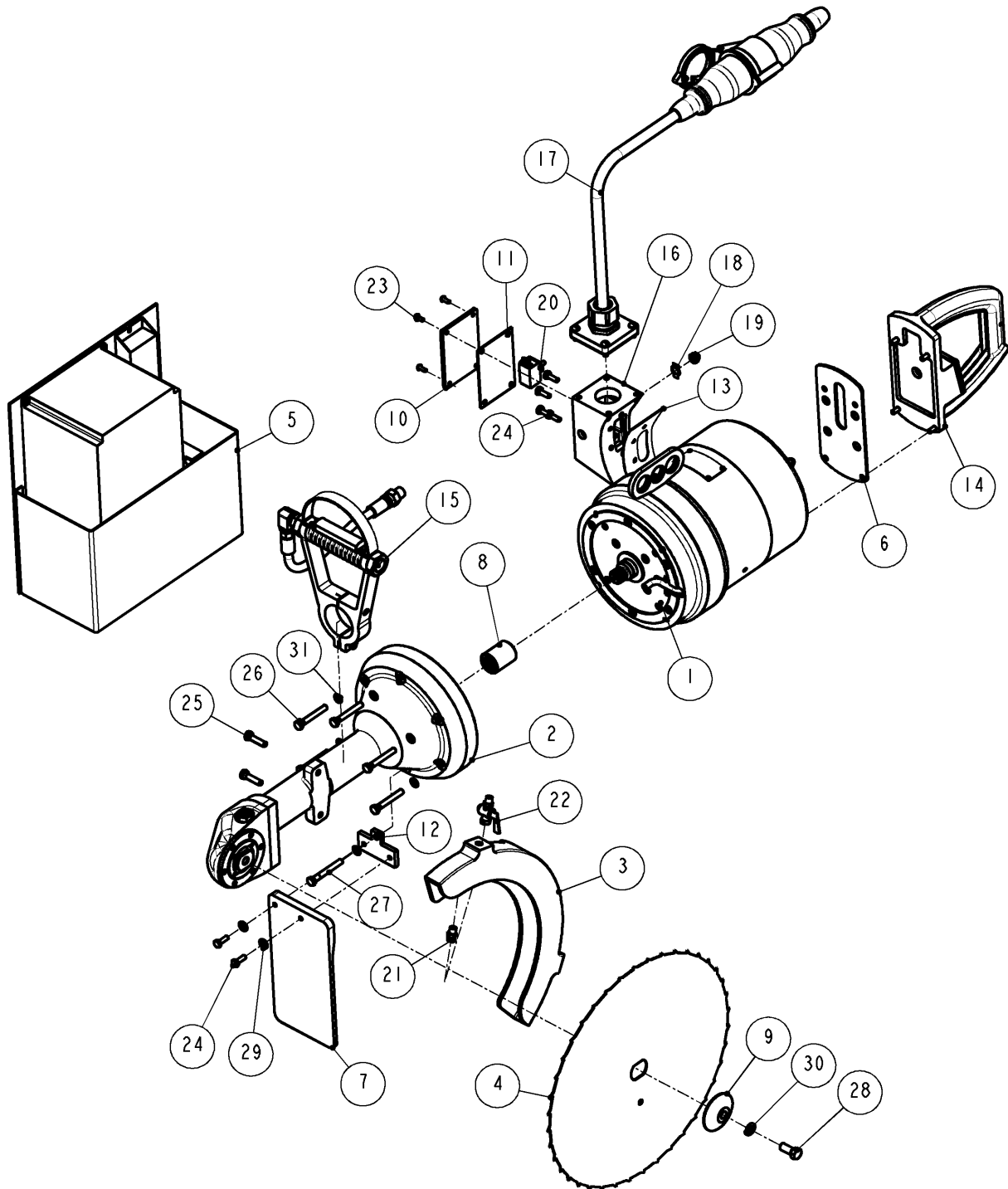

Figure 2 MODEL "160-JI" – MAIN ASSEMBLY

KENTMASTER MFG. CO., INC. 1801 SOUTH MOUNTAIN AVE., MONROVIA, CALIFORNIA 91016 UNITED STATES OF AMERICA
 ☎ TELEPHONE: (626) 359-8888 FAX: (626) 303-5151

1600510: 160-JI, HOG SPLITTING SAW (WITH INVERTER)			
1600570: 160-JI, HOG SPLITTING SAW (INVERTER NOT INCLUDED)			
ITEM	PART #	DESCRIPTION	QTY
1	OPTIONS	MOTOR ASSEMBLY, 3HP	1
2	1302970	DRIVE SHAFT HOUSING - NOSE, STANDARD TORQUE	1
	1302552	DRIVE SHAFT HOUSING - NOSE, HIGH TORQUE	1
3	1302500	GUARD FOR 16" BLADE	1
4	4000550	16" SAW BLADE, 40 TEETH, DOUBLE SKIP TOOTH	1
	4000180	16" SAW BLADE, 120 TEETH, THIN RIM	1
	4000490	16" SAW BLADE, 40 TEETH, DOUBLE SKIP TOOTH, HEAVY-DUTY	1
5	7400151	VARIABLE DRIVE ASS'Y, 5HP, 380V - 460V, 3PH – INVERTER	1
	7400163	VARIABLE DRIVE ASS'Y, 5HP, 200V - 240V, 3PH – INVERTER	1
6	1001940	INSULATION PLATE	1
7	1300180	SPLASH GUARD	1
8	1300400	SLEEVE	1
9	1300830	FLANGE - SAW BLADE	1
10	1301800	COVER, WIRE BOX	1
11	1301870	GASKET	1
12	1302150	MOUNTING PLATE	1
13	1302350	GASKET	1
14	1302550	REAR HANDLE ASSEMBLY, ATD	1
15	1302560	FORWARD HANDLE ASSEMBLY, ATD	1
16	1302620	WIRE BOX	1
17	1302963	POWER SUPPLY, NON 42V	1
18	2000130	ON-OFF PLATE	1
19	2000140	BOOT, TOGGLE SWITCH	1
20	2000730	SWITCH	1
21	7011650	SPRAY NOZLE	1
22	7025110	SHUT OFF VALVE	1
23	8029040	SCREW	4
24	8411060	SCREW	6
25	8413100	SCREW	2
26	8413180	SCREW	5
27	8413200	SCREW	1
28	8417580	SCREW	1
29	8505100	WASHER	2
30	8506170	WASHER	1
31	8507150	WASHER	8

Figure 3 BOM FOR MODEL “160-JI”

MOTOR ASSEMBLY, 3HP

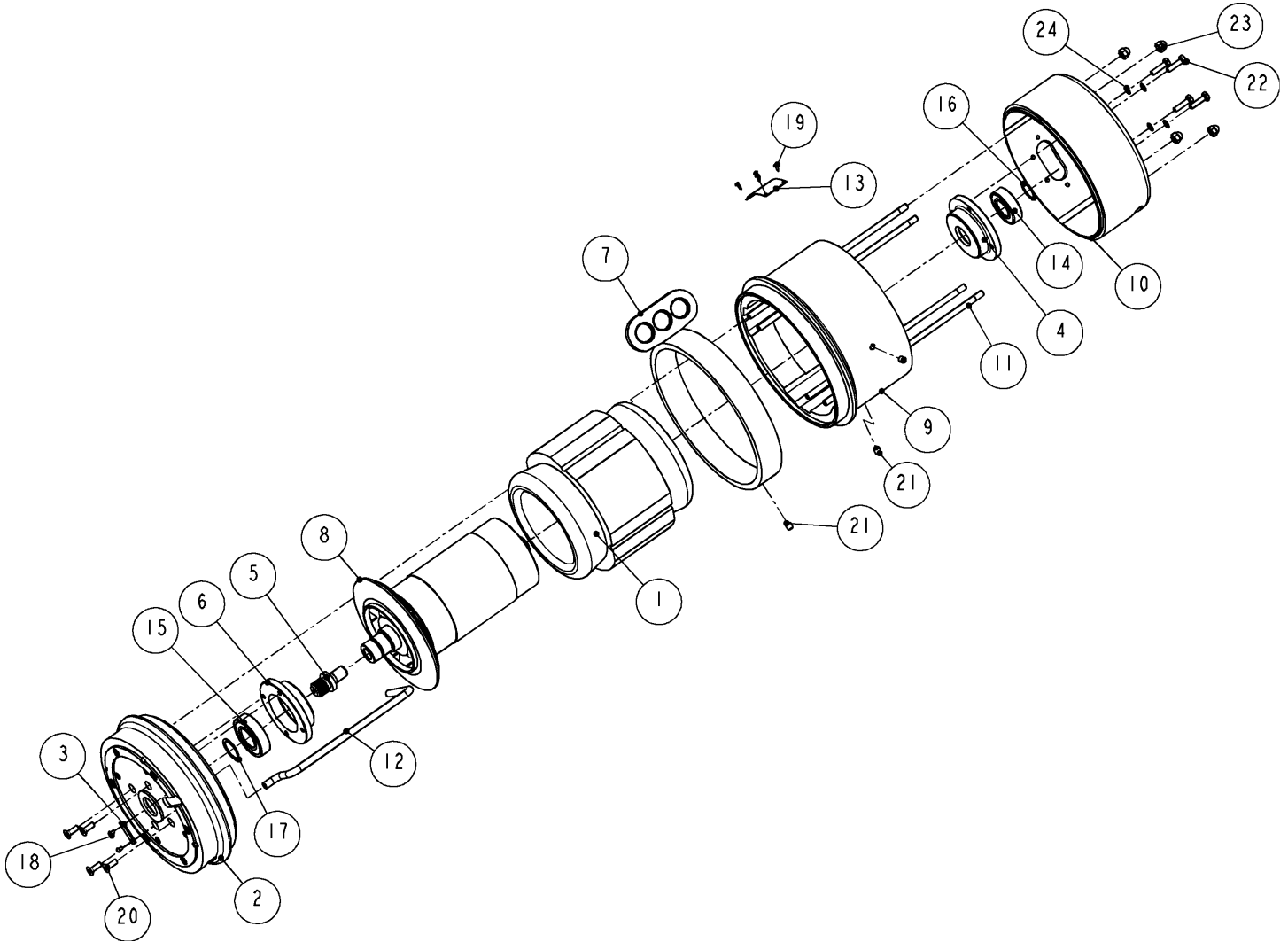

Figure 4 3HP MOTOR ASSEMBLY

KENTMASTER MFG. CO., INC. 1801 SOUTH MOUNTAIN AVE., MONROVIA, CALIFORNIA 91016 UNITED STATES OF AMERICA

☎ TELEPHONE: (626) 359-8888 FAX: (626) 303-5151

MOTOR ASSEMBLY 416V, 3PH, 50HZ, 3HP, 4.3 AMPS	1600830-416-350	2340130
MOTOR ASSEMBLY 208V, 3PH, 50HZ, 3HP, 8.3 AMPS	1600830-208-350	2340130
MOTOR ASSEMBLY 380V, 3PH, 50HZ, 3HP, 5.1 AMPS	1600820-380-350	2340120
MOTOR ASSEMBLY 220V, 3PH, 50HZ, 3HP, 8.8 AMPS	1600820-220-350	2340120
MOTOR ASSEMBLY 230V, 3PH, 50HZ, 3HP, 8.8 AMPS	1600810-230-350	2340110
MOTOR ASSEMBLY 115V, 3PH, 50HZ, 3HP, 17.6 AMPS	1600810-115-350	2340110
MOTOR ASSEMBLY 42V, 3PH, 50HZ, 3HP, 47.0AMPS	1600800	2340100
MOTOR ASSEMBLY 460V, 3PH, 60HZ, 3HP, 4.1AMPS	1600830-460-360	2340130
MOTOR ASSEMBLY 230V, 3PH, 60HZ, 3HP, 8.2AMPS	1600830-230-360	2340130
MOTOR ASSEMBLY 550V, 3PH, 60HZ, 3HP, 3.8AMPS	1600850	2340150
MOTOR ASSEMBLY 380V, 3PH, 60HZ, 3HP, 5.0AMPS	1600840-380-360	2340140
MOTOR ASSEMBLY 220V, 3PH, 60HZ, 3HP, 8.6AMPS	1600840-220-360	2340140
MOTOR OPTION DESCRIPTION	MOTOR ASSEMBLY	STATOR
160-JB AND 160 JB-A MOTOR ASSEMBLY		

16008 : MOTOR ASSEMBLY, 3HP			
ITEM	PART #	DESCRIPTION	QTY
1	OPTIONS	STATOR	1
2	1000070	MOTOR, FRONT END BELL	1
3	1000190	CLAMP	1
4	1300070	HOUSING - REAR MOTOR BRG.	1
5	1300390	SPLINE BOLT - DRIVE	1
6	1300710	HOUSING - FRONT MOTOR BRG.	1
7	1302173	HANGER	1
8	1600630	ROTOR ASSEMBLY, 3 HP	1
9	1600640	MOTOR SHELL	1
10	1600680	MOTOR END BELL - REAR	1
11	1600690	ROD	4
12	1600710	WIRE CONDUICT	1
13	2000040	NAME PLATE	1
14	3204050	BEARING	1
15	3204060	BEARING	1
16	5100980	RETAINING RING	1
17	5101180	RETAINING RING	1
18	8026020	SCREW	2
19	8081020	SCREW	4
20	8241060	SCREW	4
21	8313030	SET SCREW	3
22	8411080	SCREW	4
23	8501130	NUT	4
24	8507100	WASHER	4

Figure 5 BOM FOR 3HP MOTOR ASSEMBLY

1600630: ROTOR ASSEMBLY, 3 HP			
ITEM	PART #	DESCRIPTION	QTY
1	1600730	IMPELLER	1
2	1600620	SHAFT	1
3	2340610	ROTOR	1

Figure 6 ROTOR ASSEMBLY, 3HP

Rotor- Shaft – Impeller Assembly (Item 1600730) has to be balanced.

MOTOR DISASSEMBLY AND RE-ASSEMBLY PROCEDURE

1. RODS (ITEM 1600690) ARE ASSEMBLED TO BELL. AVOID HITTING WINDINGS OF STATOR WITH LOOSE ENDS OF RODS.
2. USING A GEAR PULLER, PULL HOUSINGS (ITEMS 4 AND 6, FIG. 4) FROM SHAFT (ITEM 8, FIG 4)
3. PULL STATOR (ITEM 1, FIG. 4) OUT OF SHELL (ITEM 9, FIG.4). (APPLYING HEAT (ABOUT 200° F, 93° C) TO SHELL WILL EXPAND IT. STATOR WILL BE EASIER TO REMOVE.

TO REASSEMBLY MOTOR REVERSE STEPS 1 TO 3.

POWER SUPPLY

POWER SUPPLY 14/7

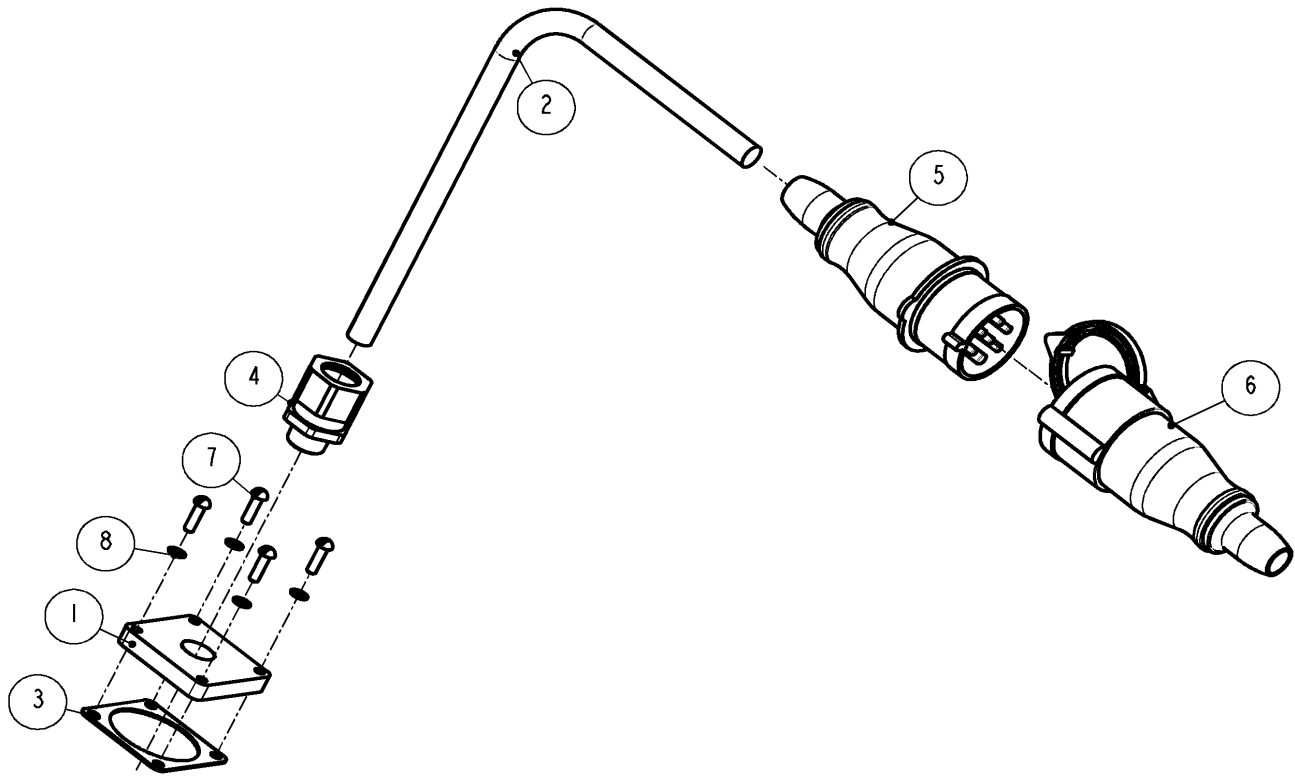

1302963: POWER SUPPLY, NON 42V (14/7)			
ITEM	PART #	DESCRIPTION	QTY
1	1302635	GASKET	1
2	2001080	POWER CORD	1
3	2001160	GASKET	1
4	2001270	CABLE CONNECTOR	1
5	2001610	PLUG, MALE	1
6	2001620	SOCKET, FEMALE	1
7	8031070	SCREW	4
8	8507100	WASHER	4

Figure 7 1302963: POWER SUPPLY, 14/7

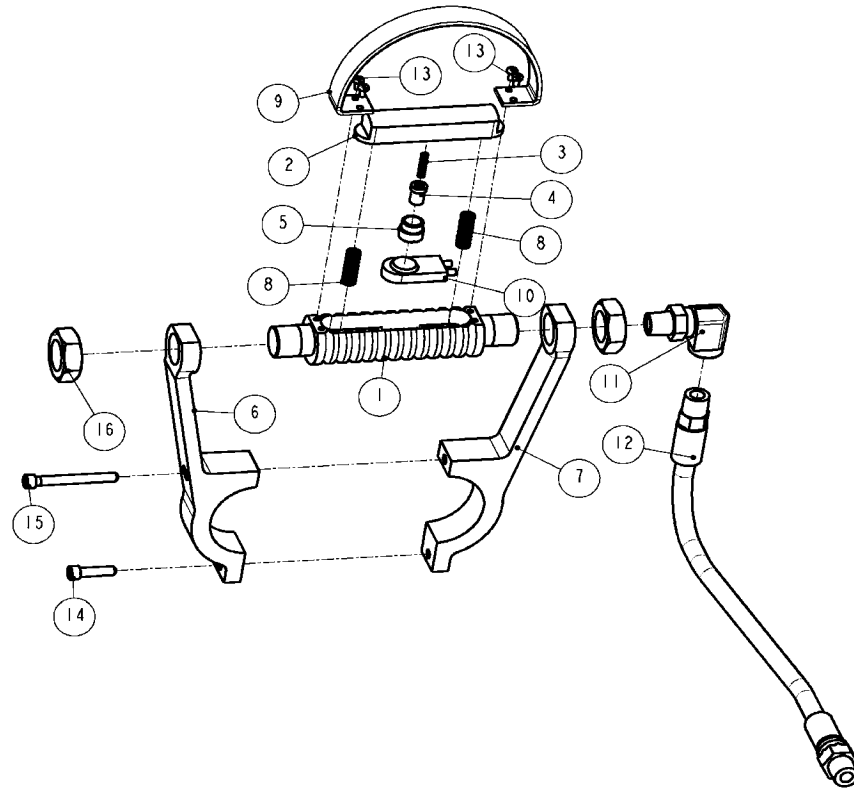
HANDLES**FRONT HANDLE****HANDLE DISASSEMBLY:**

1. In the wirebox identify wires to switch of handle assembly. Identify which wires they connect with prior to removing caps. Refer to wiring diagram.
2. Pull out switch (Item 10, Fig. 8).
3. The drilled hole in the housing (item 1) has been filled with silicon to help keep moisture out of electrical system. Remove silicon prior to reassembly.

HANDLE REASSEMBLY:

1. Reverse steps 1 and 2 of "Handle disassembly".
2. After installing switch, fill drilled hole that switch wires were sent thru with silicon. This helps keep moisture out of electrical system.
3. Insert closed end of spring (item 3) into plunger (item 4).

1302560: FORWARD HANDLE ASSEMBLY			
ITEM	PART #	DESCRIPTION	QTY
1	1302420	HANDLE	1
2	1302430	TRIGGER	1
3	1302440	SPRING	1
4	1302450	PLUNGER	1
5	1302460	HOLDER, PLUNGER	1
6	1302480	HANDLE BAR, FRONT	1
7	1302490	HANDLE BAR, REAR	1
8	1701550	SPRING	2
9	1710570	GUARD	1
10	2000690	SWITCH	1
11	7018750	ELBOW	1
12	7310120	HOSE, ARMORED	1
13	8086020	SCREW	4
14	8211080	SCREW	1
15	8211180	SCREW	1
16	8500580	NUT	2

Figure 8 1302560: FORWARD HANDLE ASSEMBLY

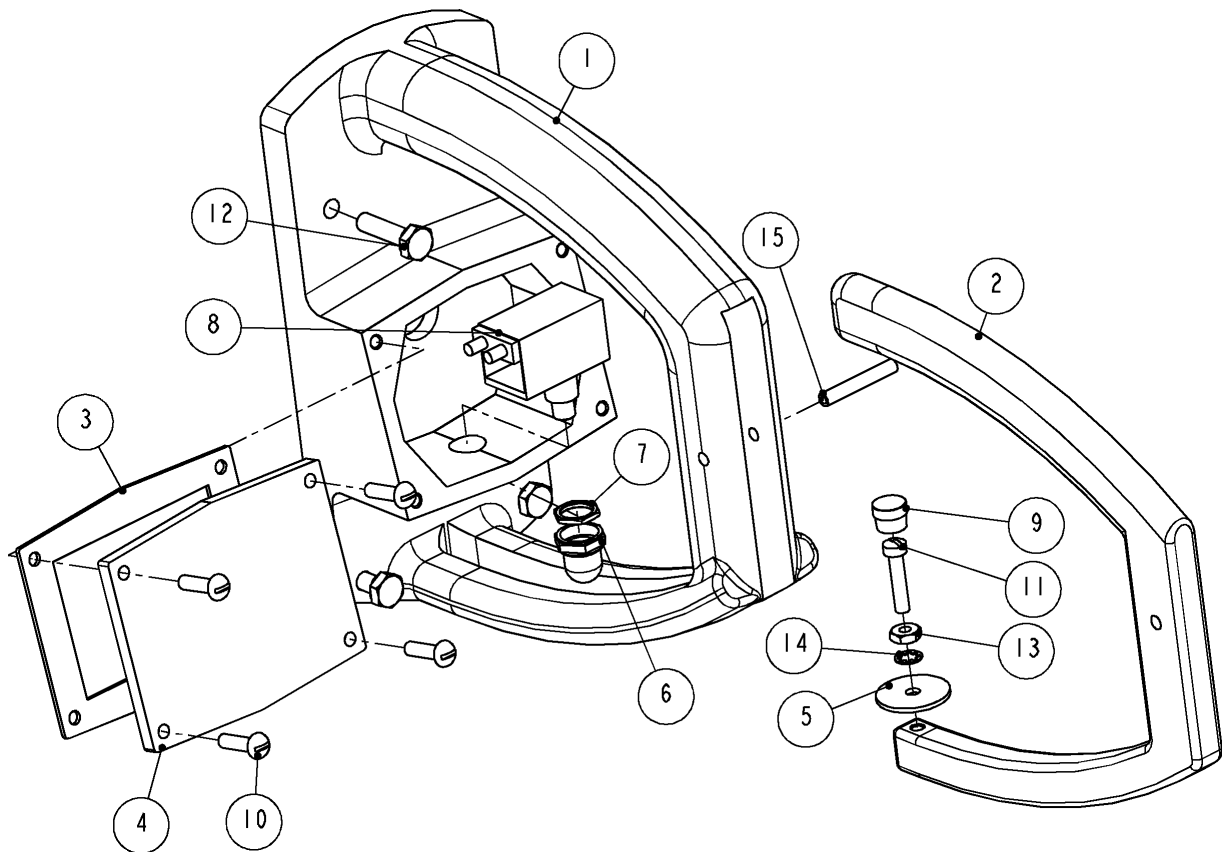
REAR HANDLE

1302550: REAR HANDLE ASSEMBLY			
ITEM	PART #	DESCRIPTION	QTY
1	1302220	HANDLE - REAR	1
2	1302230	TRIGGER, REAR HANDLE	1
3	1302260	GASKET	1
4	1302270	COVER	1
5	1302290	WASHER	1
6	2000020	BOOT, PUSH BUTTON	1
7	2000080	LOCKNUT	1
8	2000700	SWITCH	1
9	7018400	CAP, LUBE FITTING	1
10	8030060	SCREW	4
11	8070070	SCREW	1
12	8411080	SCREW	4
13	8500100	NUT	1
14	8507090	WASHER	1
15	8613200	PIN	1

Figure 9 1302550: REAR HANDLE ASSEMBLY

KENTMASTER MFG. CO., INC. 1801 SOUTH MOUNTAIN AVE., MONROVIA, CALIFORNIA 91016 UNITED STATES OF AMERICA

☎ TELEPHONE: (626) 359-8888 FAX: (626) 303-5151

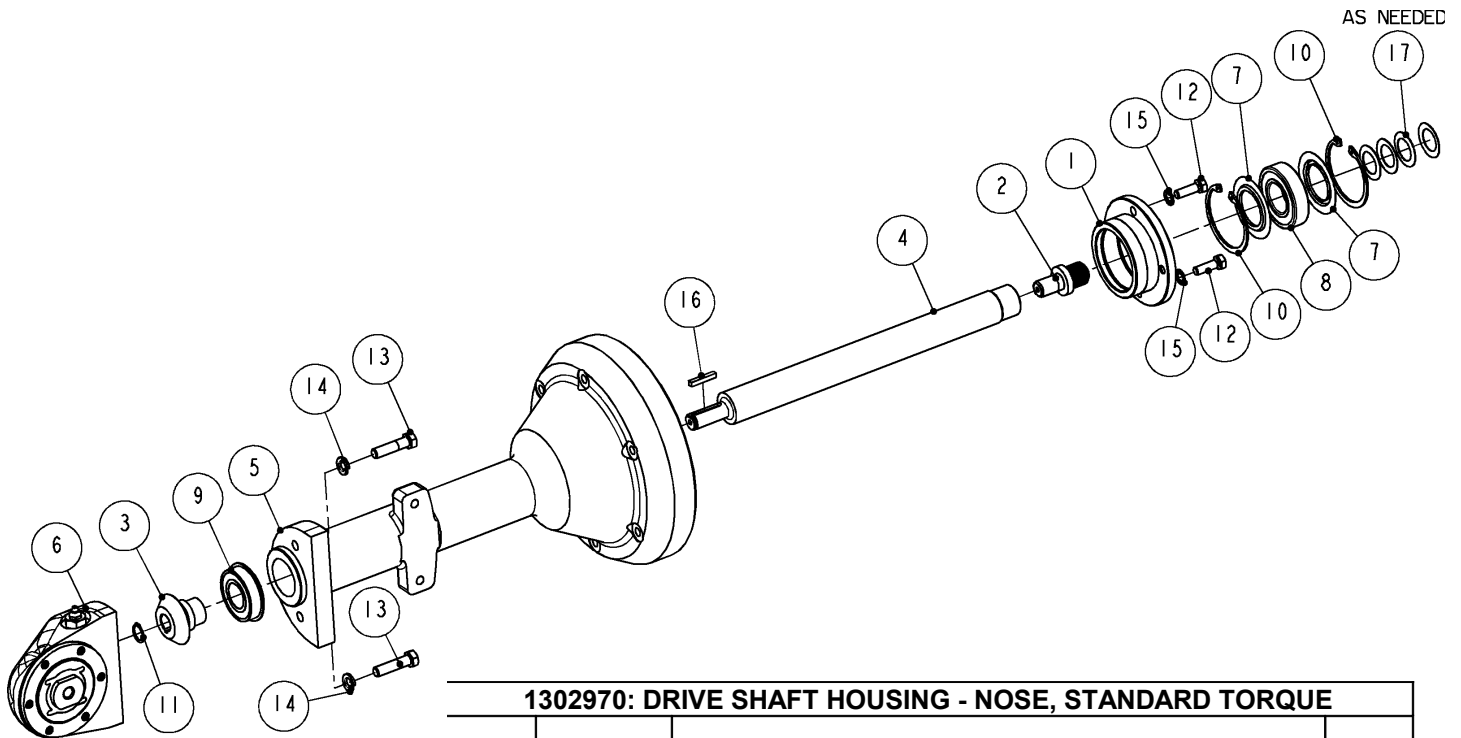
DRIVESHAFT HOUSING – NOSE ASSEMBLY**STANDARD TORQUE**

1302970: DRIVE SHAFT HOUSING - NOSE, STANDARD TORQUE			
ITEM	PART #	DESCRIPTION	QTY
1	1300350	SLEEVE - DRIVE SHAFT	1
2	1300390	SPLINE BOLT - DRIVE	1
3	1302360	PINION, STANDARD TORQUE	1
4	1302380	SHAFT	1
5	1302510	DRIVE HOUSING	1
6	1302530	SAW MANDREL NOSE ASSEMBLY, STANDARD	1
7	3002560	RING	2
8	3204060	BEARING	1
9	3214050	BEARING	1
10	5002440	RETAINING RING	2
11	5100620	RETAINING RING	1
12	8413080	SCREW	2
13	8415120	SCREW	2
14	8506160	WASHER	2
15	8507150	WASHER	2
16	8603090	SQUARE KEY	1
17	8712020	SPRING WASHER, AS NEEDED	4

Figure 10 1302970: DRIVE SHAFT HOUSING – NOSE, STANDARD TORQUE

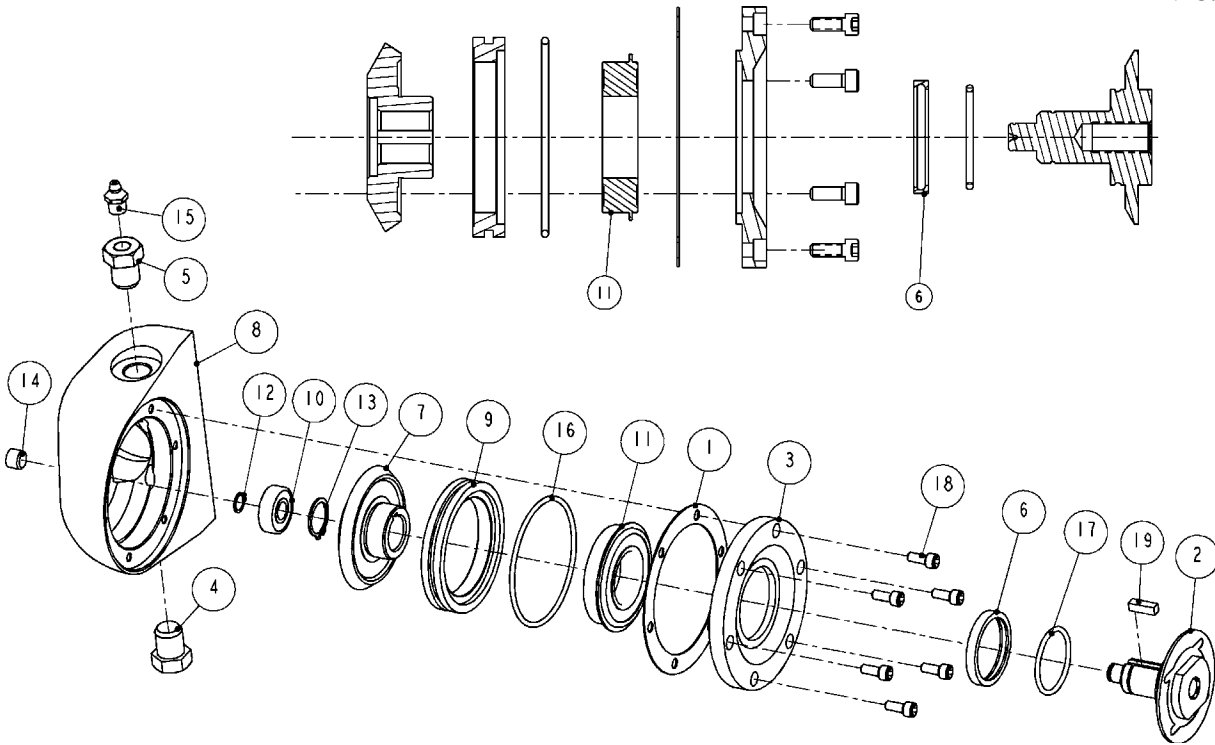

STANDARD TORQUE GEAR SET:

1302360 – BEVEL PINION GEAR (SEE 1302970)

1302370 – BEVEL GEAR (SEE NOSE 1302530)

BLADE: 1100 RPM

NOSE DISASSEMBLY:

1. Remove six screws (Item 18).
2. Using a 3/16” hex wrench, remove plug (Item 14)
3. With a center punch inserted thru back of nose (Item 8), press out mandrel (Item 2). All internal parts should come out at this time.

NOSE REASSEMBLY:

1. Reassemble all parts in reverse order.
2. Refer to Fig. 14 for proper assembly orientation of ring and bearing (Items 6 and Item 11).

1302530: SAW MANDREL NOSE ASSEMBLY, STANDARD			
ITEM	PART #	DESCRIPTION	QTY
1	1001780	GASKET	1
2	1300190	SAW MANDREL	1
3	1300200	COVER	1
4	1301580	PLUG	1
5	1301590	LUBE PLUG	1
6	1301620	RING	1
7	1302370	BEVEL GEAR, STANDARD	1
8	1302390	NOSE - SAW MANDREL	1
9	1302520	COLLAR BEARING	1
10	3124000	BEARING	1
11	3134060	BEARING	1
12	5100390	RETAINING RING	1
13	5100750	RETAINING RING	1
14	7000010	PLUG	1
15	7016100	LUBE FITTING	1
16	7681470	O-RING	1
17	7701250	O-RING	1
18	8209040	SCREW	6
19	8603050	SQUARE KEY	1

Figure 11 1302530: NOSE ASSEMBLY, STANDARD TORQUE

HIGH TORQUE

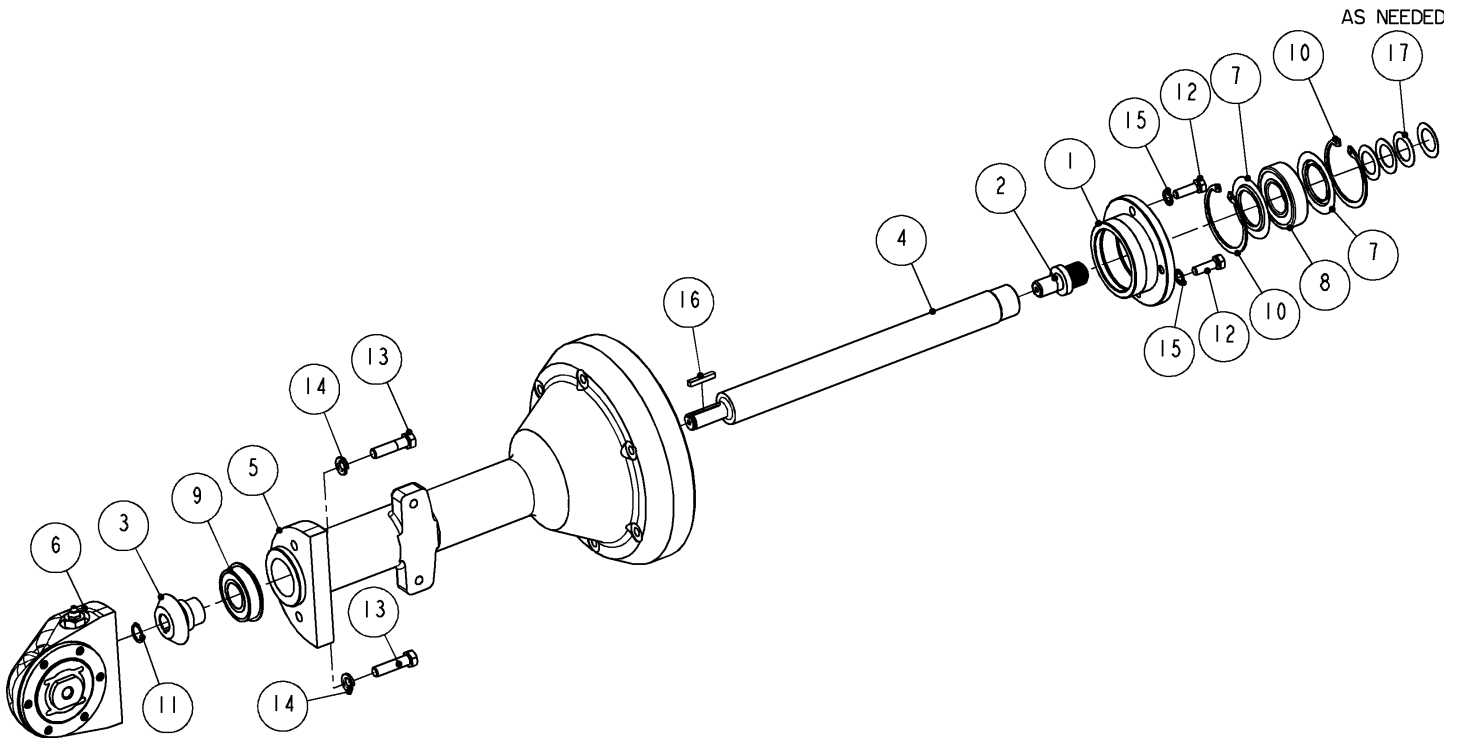

1302552: DRIVE SHAFT HOUSING - NOSE, HIGH TORQUE			
ITEM	PART #	DESCRIPTION	QTY
1	1300350	SLEEVE - DRIVE SHAFT	1
2	1300390	SPLINE BOLT - DRIVE	1
3	1302610	PINION, HIGH TORQUE	1
4	1302380	SHAFT	1
5	1302510	DRIVE HOUSING	1
6	1302531	SAW MANDREL NOSE ASSEMBLY, HIGH TORQUE	1
7	3002560	RING	2
8	3204060	BEARING	1
9	3214050	BEARING	1
10	5002440	RETAINING RING	2
11	5100620	RETAINING RING	1
12	8413080	SCREW	2
13	8415120	SCREW	2
14	8506160	WASHER	2
15	8507150	WASHER	2
16	8603090	SQUARE KEY	1
17	8712020	SPRING WASHER, AS NEEDED	4

Figure 12 1302552: DRIVE SHAFT HOUSING - NOSE, HIGH TORQUE

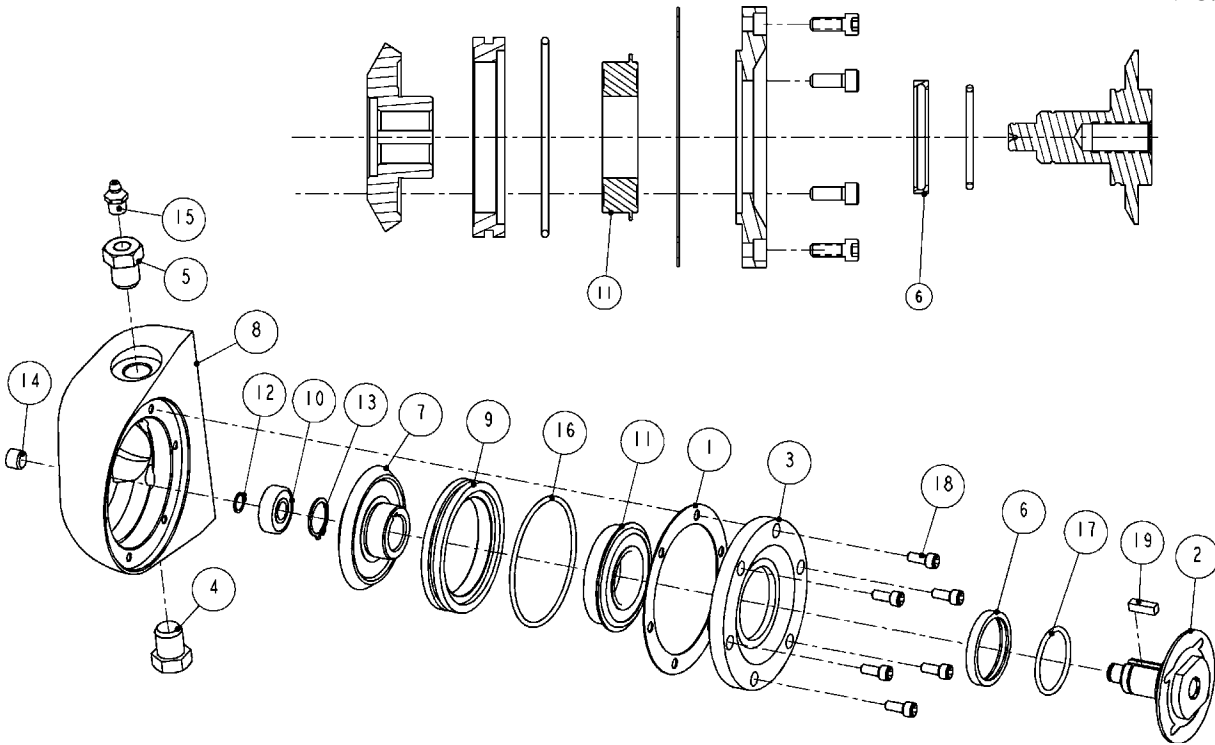

HIGH TORQUE GEAR SET:

1302610 – BEVEL PINION GEAR (SEE 1302552)
 1302600 – BEVEL GEAR (SEE NOSE 1302531)
 BLADE: 1000 RPM

NOSE DISASSEMBLY:

4. Remove six screws (Item 18).
5. Using a 3/16” hex wrench, remove plug (Item 14)
6. With a center punch inserted thru back of nose (Item 8), press out mandrel (Item 2). All internal parts should come out at this time.

NOSE REASSEMBLY:

3. Reassemble all parts in reverse order.
4. Refer to Fig. 16 for proper assembly orientation of ring and bearing (Items 6 and Item 11).

1302531: SAW MANDREL NOSE ASSEMBLY, HIGH TORQUE			
ITEM	PART #	DESCRIPTION	QTY
1	1001780	GASKET	1
2	1300190	SAW MANDREL	1
3	1300200	COVER	1
4	1301580	PLUG	1
5	1301590	LUBE PLUG	1
6	1301620	RING	1
7	1302600	BEVEL GEAR, HIGH TORQUE	1
8	1302390	NOSE - SAW MANDREL	1
9	1302520	COLLAR BEARING	1
10	3124000	BEARING	1
11	3134060	BEARING	1
12	5100390	RETAINING RING	1
13	5100750	RETAINING RING	1
14	7000010	PLUG	1
15	7016100	LUBE FITTING	1
16	7681470	O-RING	1
17	7701250	O-RING	1
18	8209040	SCREW	6
19	8603050	SQUARE KEY	1

Figure 13 1302531: NOSE ASSEMBLY – HIGH TORQUE

INVERTER ASS'Y AND WIRING DIAGRAM

MACHINE WIRING

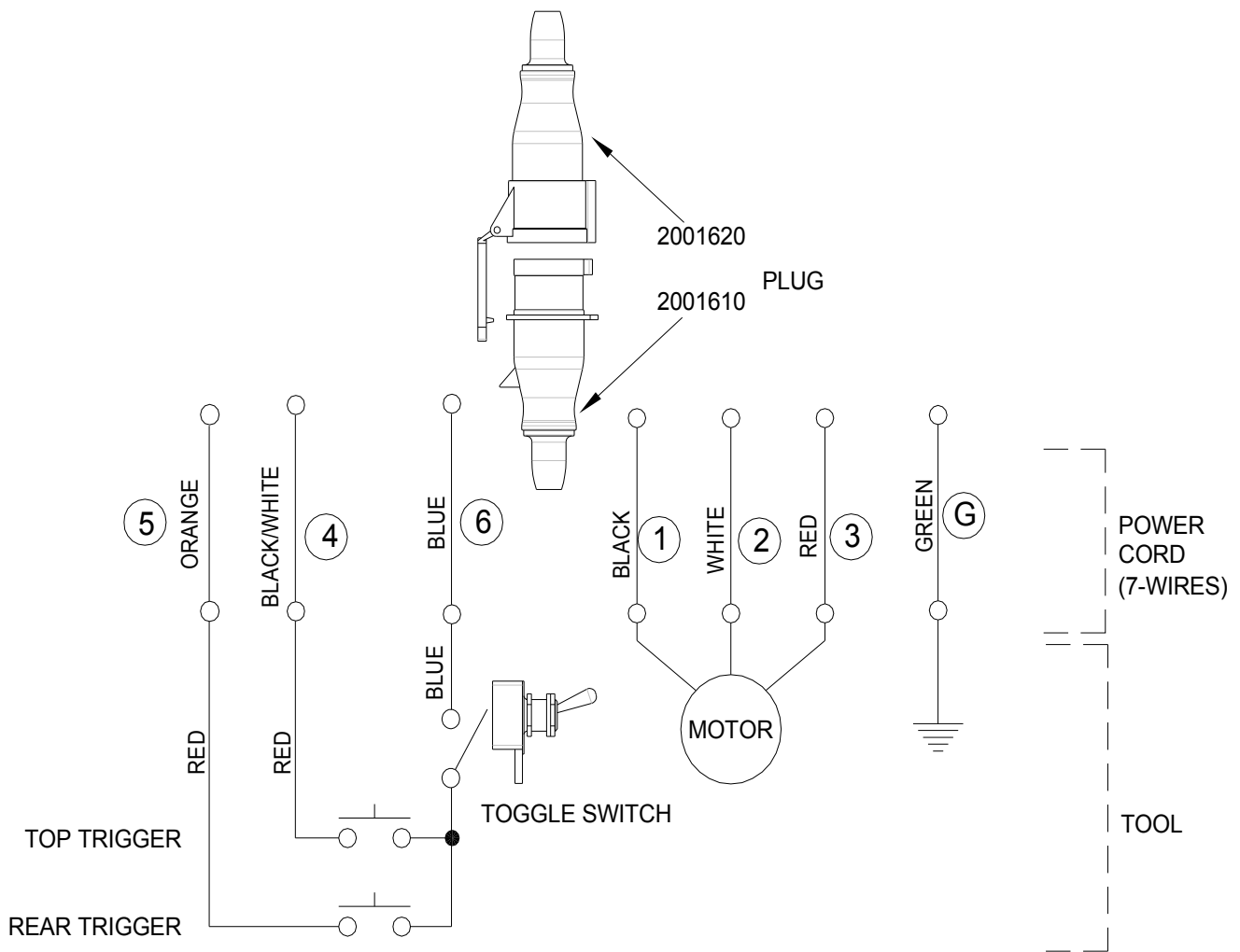
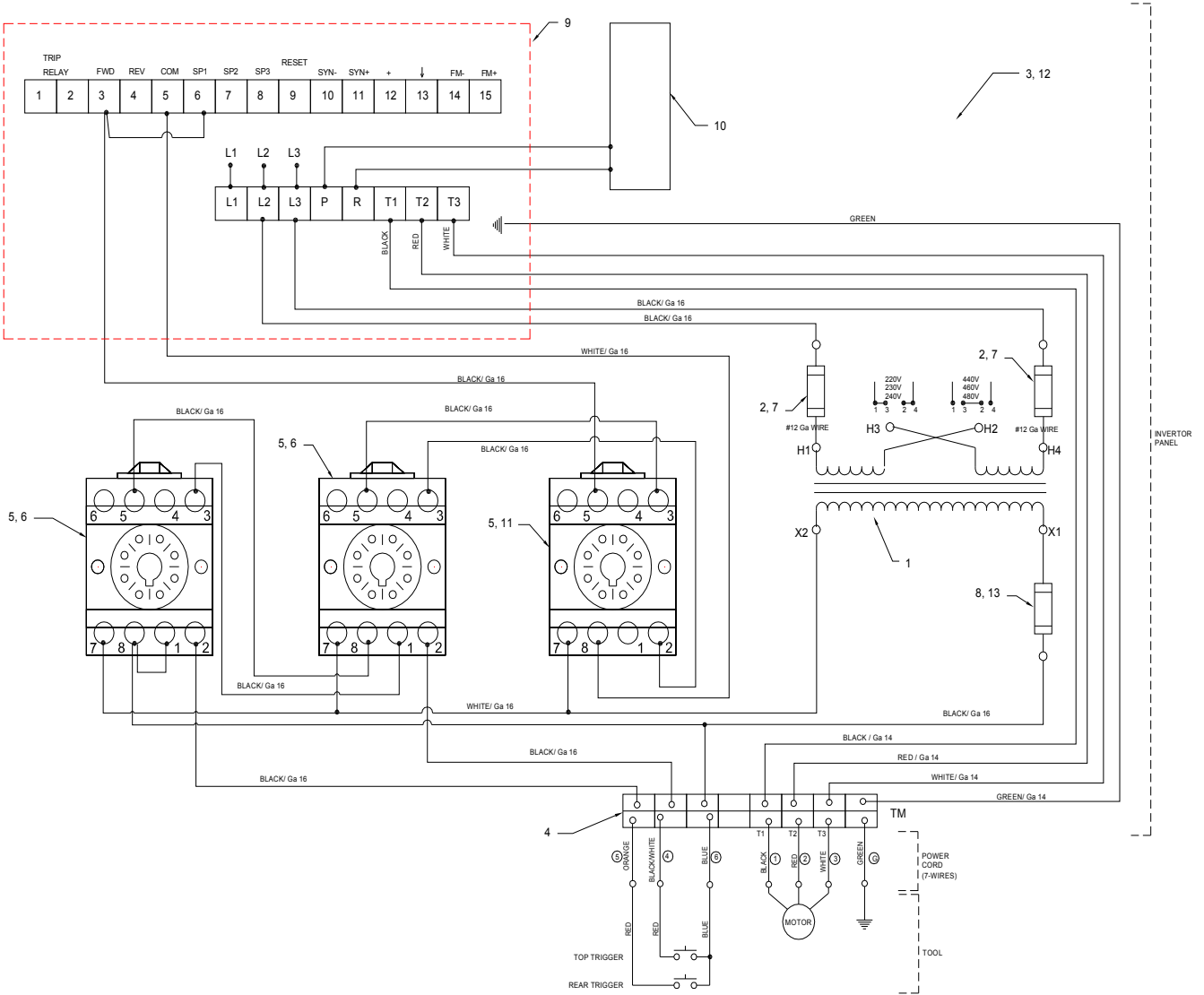

Figure 14 160-JI (1600510 AND 1600570) WIRING DIAGRAM

200V - 240V VOLTAGE - INVERTER



1. DO NOT ATTEMPT OR MAKE REPAIRS ON THE MACHINE WHILE POWER IS ON.
2. ALL ELECTRICAL WORK MUST BE PERFORMED BY A QUALIFIED ELECTRICIAN.
3. THE ELECTRICAL DIAGRAM SHOWS THE MACHINE IN THE "OFF" POSITION.

3HP MOTOR REQUIRES 5HP INVERTER SETUP.

Figure 15 7400163: WIRING DIAGRAM - 200V - 240V

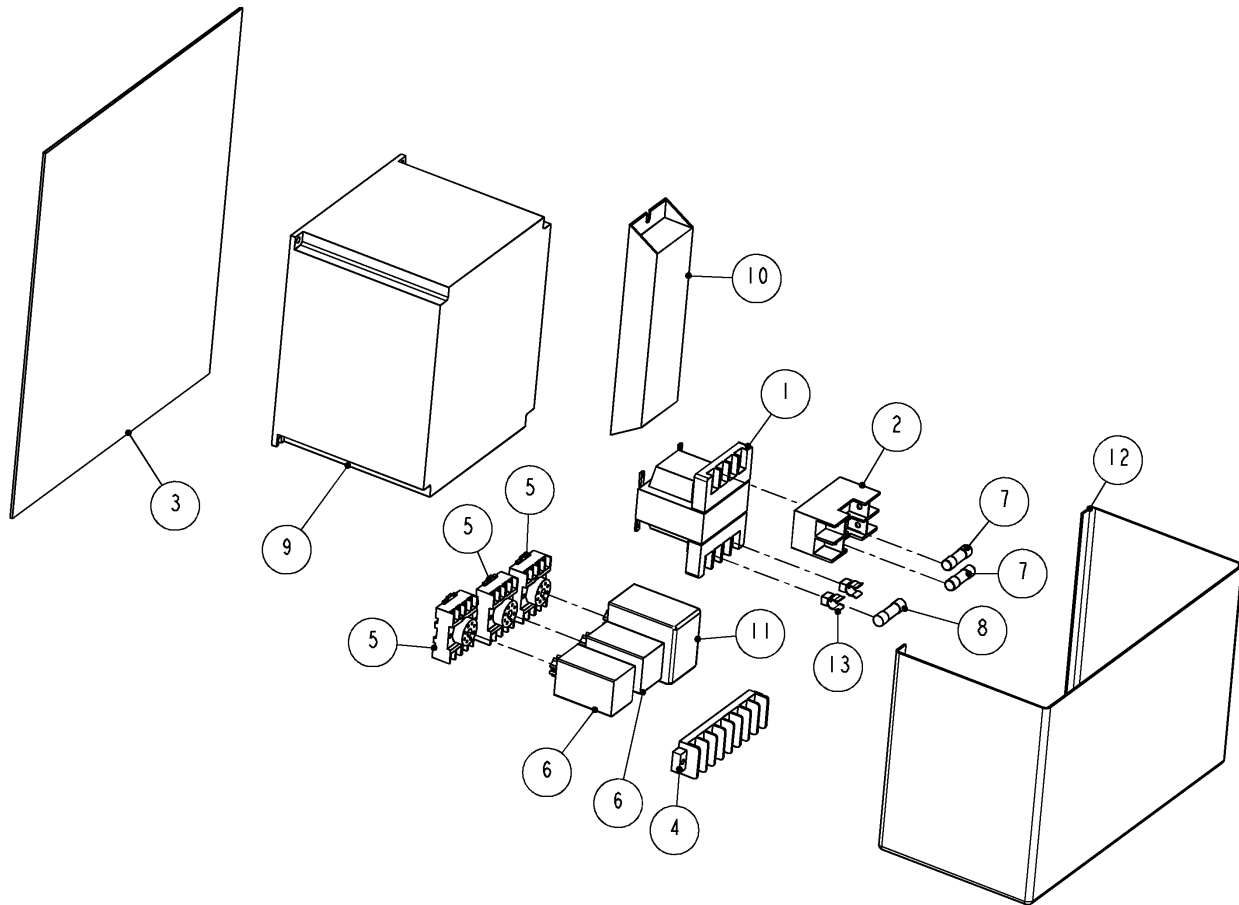

7400163: VARIABLE DRIVE ASS'Y, 5HP, 240V, 3PH			
ITEM	PART #	DESCRIPTION	QTY
1	7400138	TRANSFORMER	1
2	7400139	FUSE BOX, PRIMARY	1
3	7400140	BACK PANEL	1
4	7400141	TERMINAL	1
5	7400142	SOCKET, 8 PIN	3
6	7400143	RELAY	2
7	7400144	FUSE	2
8	7400145	FUSE	1
9	7400164	VARIABLE FREQUENCY DRIVE, 5HP, 240V, 3PH	1
10	7400165	BRAKE RESISTOR	1
11	7400148	ANTI TIE-DOWN	1
12	7400152	COVER	1
13	7400153	FUSE BOX, SECONDARY	1

Figure 16 7400163: INVERTER, 200V – 240V

400V – 460V VOLTAGE - INVERTER

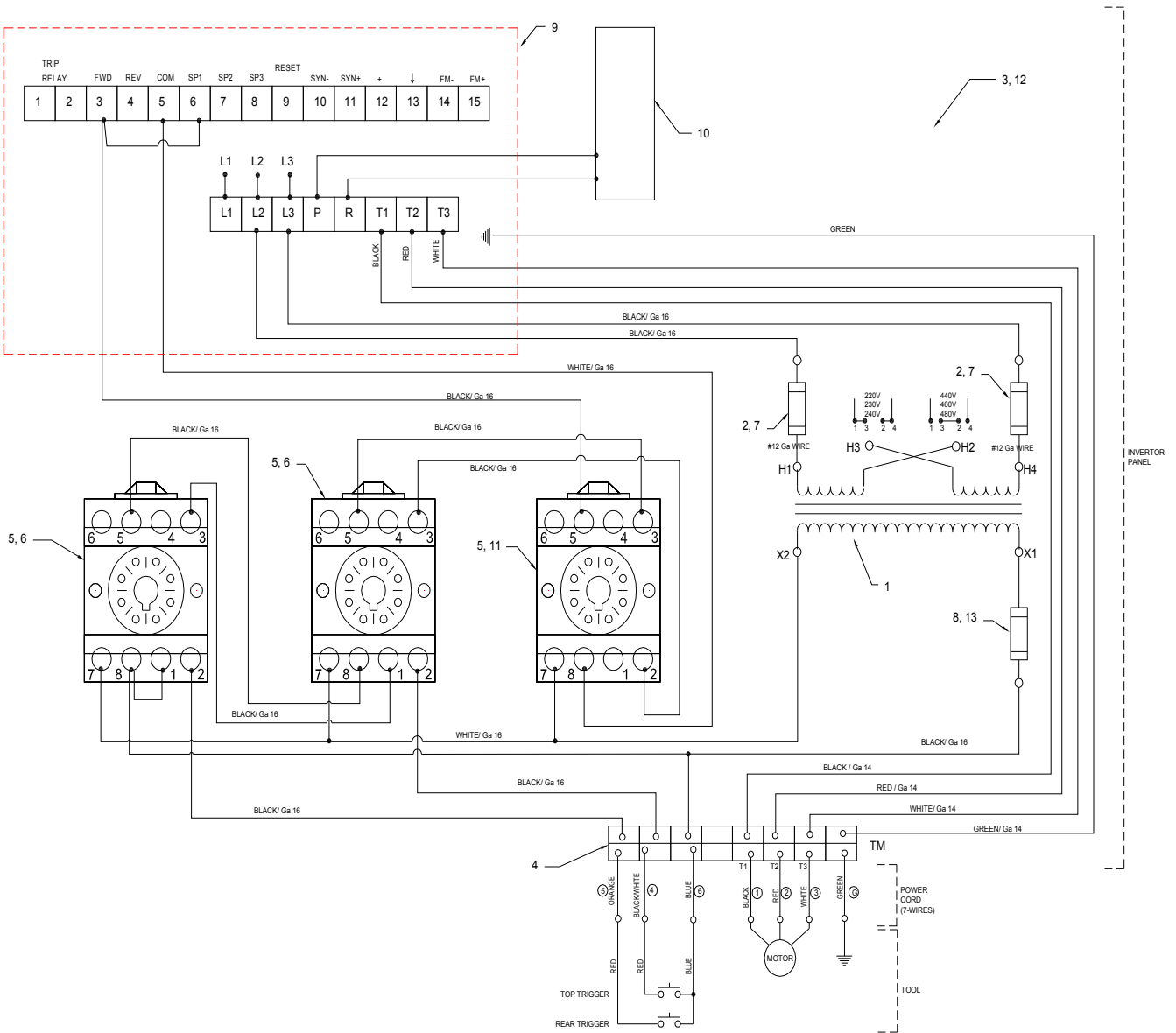

1. DO NOT ATTEMPT OR MAKE RAPAIRS ON THE MACHINE WHILE POWER IS ON.
2. ALL ELECTRICAL WORK MUST BE PERFORMED BY A QUALIFIED ELECTRICIAN.
3. THE ELECTRICAL DIAGRAM SHOWS THE MACHINE IN THE “OFF” POSITION.

3HP MOTOR REQUIRES 5HP INVERTER SETUP.

Figure 17 7400151:WIRING DIAGRAM - 400V – 460V

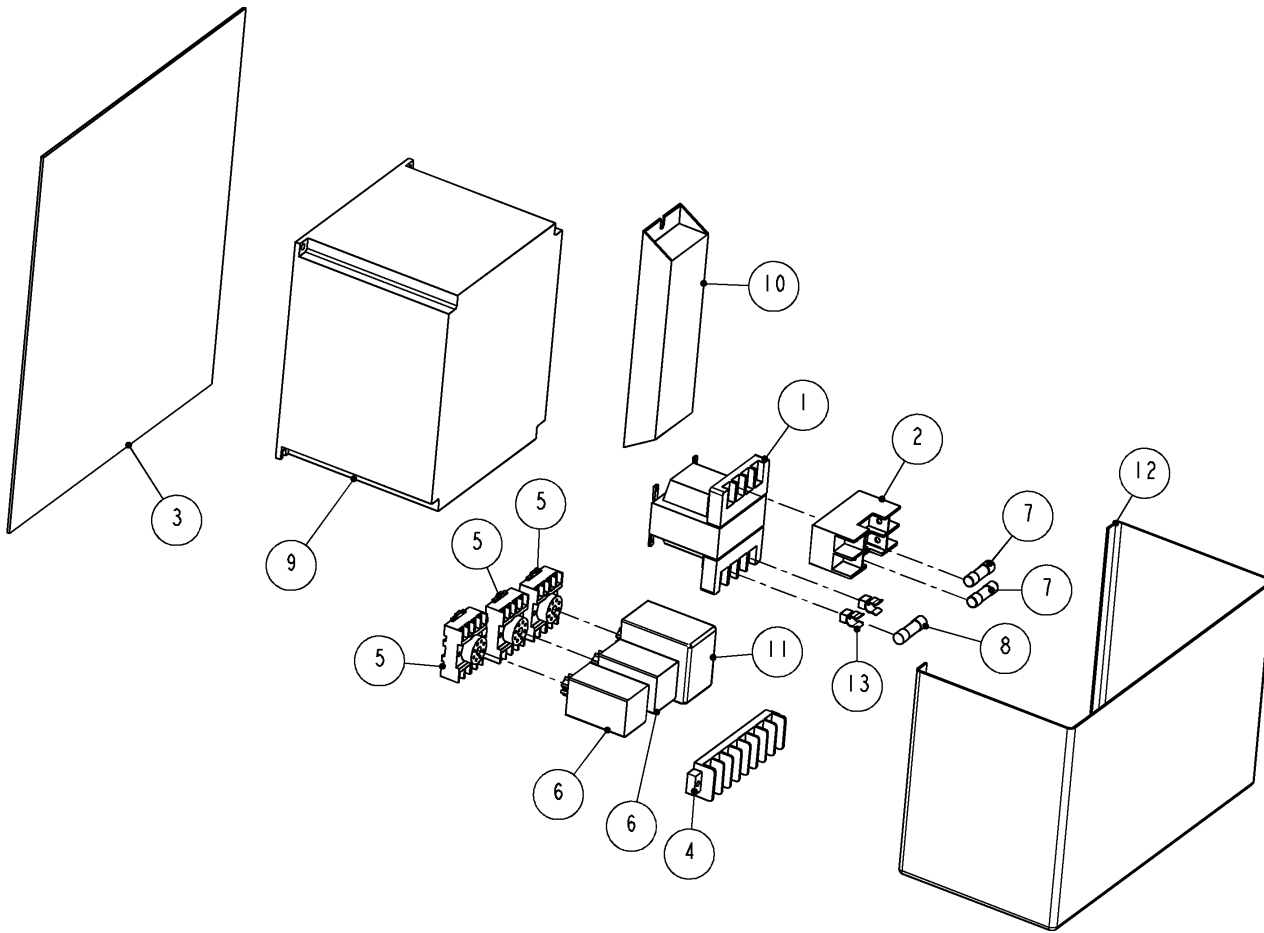

7400151: VARIABLE DRIVE ASS'Y, 5HP, 400V - 460V, 3PH			
ITEM	PART #	DESCRIPTION	QTY
1	7400138	TRANSFORMER	1
2	7400139	FUSE BOX, PRIMARY	1
3	7400140	BACK PANEL	1
4	7400141	TERMINAL	1
5	7400142	SOCKET, 8 PIN	3
6	7400143	RELAY	2
7	7400144	FUSE	2
8	7400145	FUSE	1
9	7400149	VARIABLE FREQUENCY DRIVE, 5HP, 460V, 3PH	1
10	7400150	BRAKE RESISTOR	1
11	7400148	ANTI TIE-DOWN	1
12	7400152	COVER	1
13	7400153	FUSE BOX, SECONDARY	1

Figure 18 7400151: INVERTER, 400V – 460V

[ENGLISH]

GENERAL INFORMATION

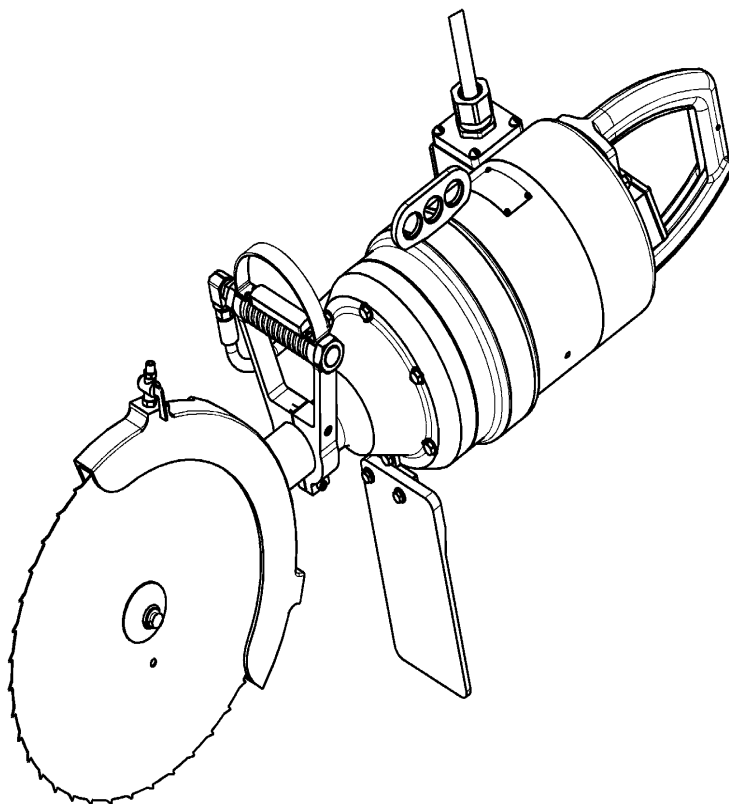

MODEL

**“160-JI” HOG SPLITTING SAW
WITH INVERTER**

SERVICE CENTERS

KENTMASTER MFG. CO., INC.
1801 SOUTH MOUNTAIN AVE.
MONROVIA, CALIFORNIA 91016
UNITED STATES OF AMERICA

☎ **TELEPHONE: (626) 359-8888**
FAX: (626) 303-5151

NOTICE TO EMPLOYER AND PURCHASER OF TOOL
NOTICE TO SAFETY DIRECTOR

You have purchased a powerful tool that, if misused, can cause severe injury and harm to your employees. You must instruct your employees in the safe and proper use of this tool and to follow the safety procedures and instructions that have been supplied by the manufacturer of this tool. Please follow the following instructions.

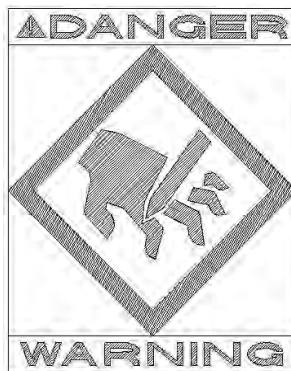

1. Instruct tool operators to test the tool each day before using it to be sure it does not malfunction. Remove and repair any tool that malfunctions.
2. Instruct tool operators to immediately stop using a tool that malfunctions or is defective.
3. Instruct personnel to immediately remove all tools that malfunction. Be sure to disconnect tool from power supply.
4. Instruct all personnel to stay clear of tool, and not to stand or walk in front of, or next to tool when in use.
5. Point out to all personnel the dangers related to the misuse of tool and the importance of following safety procedures and instructions.
6. Do not make, or allow others to make, alterations or modifications to this tool. Replace all lost or illegible labels.
7. Follow all safety, installation and maintenance instructions provided with this tool. Establish proper safety procedures in accordance with local and national requirements to prevent accidental energizing of tool that can cause injuries.
8. If this tool is sold or change in ownership takes place, you must provide the new owner all safety instructions, notices and maintenance instructions you were originally provided. You can obtain additional copies of the instructions from Kentmaster, free of charge upon request.
9. Give copies of instructions to: **(A) Tool Operators**
(B) Maintenance Supervisor
(C) Clean-up Supervisor

GENERAL INFORMATION

COVERING: SAFETY PRECAUTIONS AND PLACING INTO SERVICE
HOG SPLITTING SAW with INVERTER

READ THIS MANUAL CAREFULLY BEFORE INSTALLING, OPERATING OR SERVICING THIS TOOL

IT IS THE RESPONSIBILITY OF THE EMPLOYER TO PLACE THIS INFORMATION INTO THE HANDS OF THE OPERATOR.

PLACING INTO SERVICE

 **WARNING**

= Hazards or unsafe practices which could result in severe personal injury, death or substantial property damage.

 **CAUTION**

= Hazards or unsafe practices which could result in minor personal injury, product or property damage.

 **NOTICE**

= Important installation, operation or maintenance information.

 **WARNING**

Installation, adjustment repair and maintenance of this tool must be made by trained and qualified personnel.

 **WARNING**

Always disconnect power supply from tool before:
(A) Installing or removing blade from tool.
(B) Making repairs or adjustments to the tool.
(C) performing maintenance or cleanup work.

INDEX

<i>OPERATING AND SAFETY INSTRUCTIONS</i>	2
OPERATING INSTRUCTIONS.....	3
MAINTENANCE.....	3
BLADE REMOVAL AND CLEANING.....	3
SERVICE.....	4
<i>PARTS BOOK</i>	5
160-JI.....	5
MOTOR ASSEMBLY, 3HP.....	7
POWER SUPPLY.....	10
HANDLES.....	11
DRIVESHAFT HOUSING – NOSE ASSEMBLY.....	13
INVERTER ASS'Y AND WIRING DIAGRAM.....	17
<i>NOTICE TO EMPLOYER AND PURCHASER OF TOOL</i>	23
<i>GENERAL INFORMATION</i>	24
<i>INDEX</i>	25
<i>FIGURES - INDEX</i>	26

FIGURES - INDEX

<i>Figure 1 MODEL 160 – BLADE REPLACEMENT.....</i>	<i>4</i>
<i>Figure 2 MODEL “160-JI” – MAIN ASSEMBLY.....</i>	<i>5</i>
<i>Figure 3 BOM FOR MODEL “160-JI”.....</i>	<i>6</i>
<i>Figure 4 3HP MOTOR ASSEMBLY.....</i>	<i>7</i>
<i>Figure 5 BOM FOR 3HP MOTOR ASSEMBLY.....</i>	<i>8</i>
<i>Figure 6 ROTOR ASSEMBLY, 3HP.....</i>	<i>9</i>
<i>Figure 7 1302963: POWER SUPPLY, 14/7.....</i>	<i>10</i>
<i>Figure 8 1302560: FORWARD HANDLE ASSEMBLY.....</i>	<i>11</i>
<i>Figure 9 1302550: REAR HANDLE ASSEMBLY.....</i>	<i>12</i>
<i>Figure 10 1302970: DRIVE SHAFT HOUSING – NOSE, STANDARD TORQUE.....</i>	<i>13</i>
<i>Figure 11 1302530: NOSE ASSEMBLY, STANDARD TORQUE.....</i>	<i>14</i>
<i>Figure 12 1302552: DRIVE SHAFT HOUSING - NOSE, HIGH TORQUE.....</i>	<i>15</i>
<i>Figure 13 1302531: NOSE ASSEMBLY – HIGH TORQUE.....</i>	<i>16</i>
<i>Figure 14 160-JI (1600510 AND 1600570) WIRING DIAGRAM.....</i>	<i>17</i>
<i>Figure 15 7400163: WIRING DIAGRAM - 200V - 240V.....</i>	<i>18</i>
<i>Figure 16 7400163: INVERTER, 200V – 240V.....</i>	<i>19</i>
<i>Figure 17 7400151: WIRING DIAGRAM - 400V – 460V</i>	<i>20</i>
<i>Figure 18 7400151: INVERTER, 400V – 460V.....</i>	<i>21</i>