

# **OPERATOR'S MANUAL**

**INCLUDING: OPERATION, INSTRUCTION, INSTALLATION, MAINTENANCE AND PARTSBOOK**

---

**IMPORTANT: READ THIS MANUAL CAREFULLY BEFORE INSTALLING, OPERATING OR SERVICING THIS TOOL.**

---

## **LEG CUT-OFF AIR SAW "AL"**

### **TOOL DATA**

MODEL: AL  
ASSEMBLY NO. 6002000  
TYPE: AIR OPERATED  
NET WEIGHT: 23 LBS (10.5 KG)  
INLET AIR PRESSURE: 90 P.S.I. (6-7 BARS), 40CFM, 1 ¼ HP

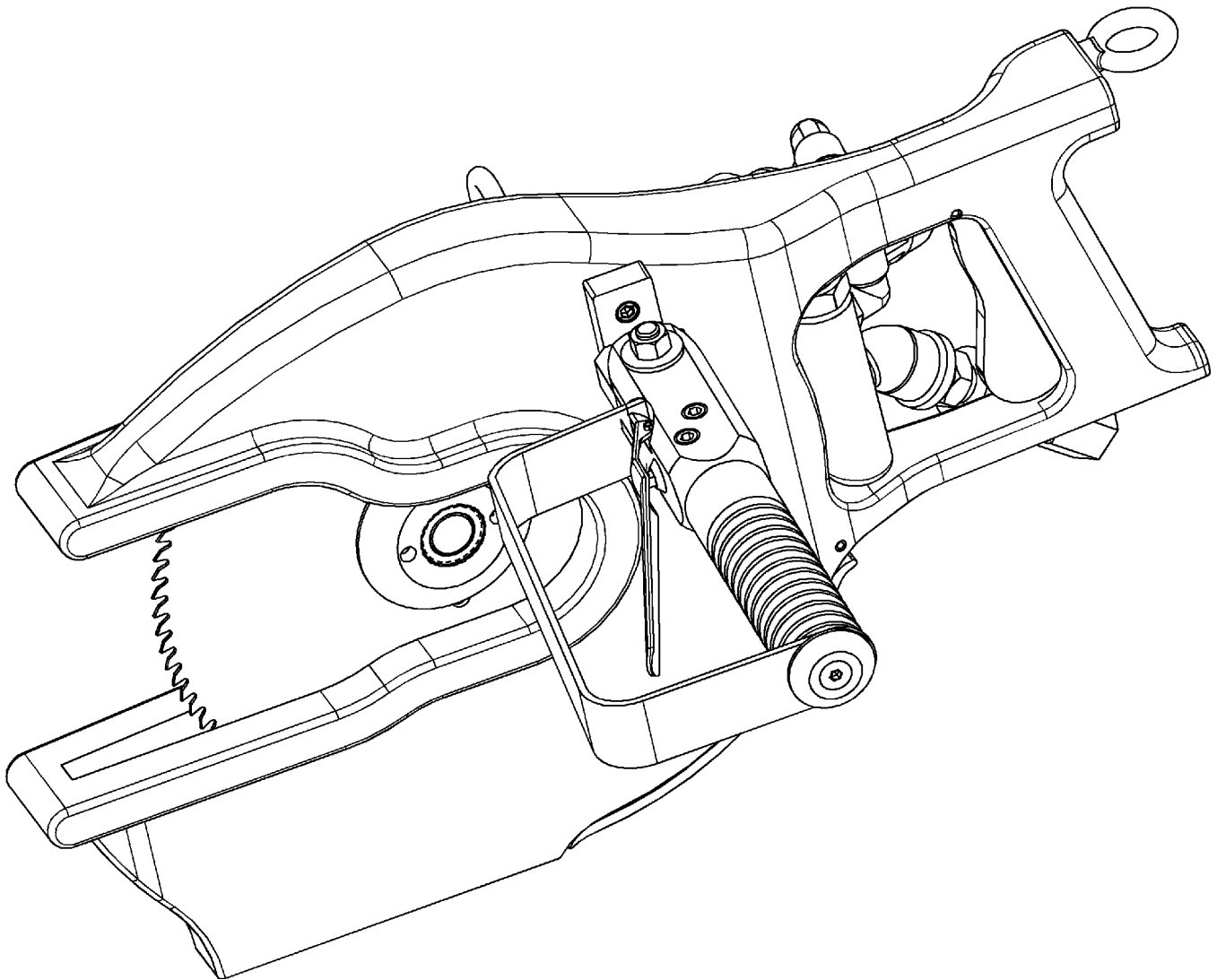

- = Hazards or unsafe practices which could result in severe personal injury, death or substantial property damage.
- = Hazards or unsafe practices which could result in minor personal injury, product or property damage.
- = Important installation, operation or maintenance information.

## **OPERATING AND SAFETY INSTRUCTIONS**

- ⚠ WARNING** DO NOT OPERATE THIS TOOL UNTIL YOU HAVE READ AND UNDERSTOOD THE SAFETY INSTRUCTIONS AND OPERATING MANUALS.
- ⚠ WARNING** DO NOT OPERATE THIS TOOL UNTIL YOU HAVE RECEIVED TRAINING IN THE HANDLING, OPERATION AND USE OF THIS TOOL.
- ⚠ WARNING** STOP USING A MALFUNCTIONING OR DEFECTIVE TOOL IMMEDIATELY. REPORT ANY PROBLEMS OR DEFECTS TO YOUR SUPERVISOR FOR REMOVAL OF THE TOOL FROM SERVICE.
- ⚠ WARNING** DO NOT ATTEMPT TO REPAIR THE TOOL YOURSELF.
- ⚠ WARNING** DO NOT ALLOW UNAUTHORIZED PERSONS TO USE TOOL.
- ⚠ WARNING** REMOVE AND DISCONNECT POWER FROM THE TOOL WHEN TOOL IS LEFT UNATTENDED OR IS NOT IN USE.
- ⚠ WARNING** NEVER TIE DOWN, BYPASS, ALTER OR MODIFY THE ACTIVATING SWITCHES OR TRIGGERS OF THIS TOOL.
- ⚠ WARNING** NEVER MAKE ALTERATIONS OR MODIFICATIONS TO THIS TOOL.
- ⚠ WARNING** BE CONSTANTLY AWARE AND ALERT FOR UNSAFE CONDITIONS AND REPORT THEM IMMEDIATELY TO YOUR SUPERVISOR.
- ⚠ WARNING** NEVER PLACE YOUR HAND OR ANY PART OF YOUR BODY IN THE CUTTING PATH OF THE TOOL.
- ⚠ WARNING** NEVER ALLOW ANYONE ELSE TO PLACE THEIR HANDS OR ANY PART OF THEIR BODY IN THE CUTTING PATH OF THE TOOL.
- ⚠ WARNING** DO NOT ACTIVATE CONTROL SWITCHES OR TRIGGERS OF THIS TOOL UNLESS YOU INTEND TO TEST OR OPERATE THIS TOOL.
- ⚠ WARNING** DO NOT USE THIS TOOL FOR ANY PURPOSE OTHER THAN IT'S INTENDED PURPOSE.
- WHEN OPERATING THIS TOOL WEAR THE PROTECTIVE GEAR AND SAFETY EQUIPMENT SUPPLIED TO YOU.
- ⚠ WARNING** THE NOISE EMISSION (SOUND PRESSURE LEVEL) AT THE WORKSTATION MAY EXCEED 80 dB (A). EAR AND SOUND PROTECTION GEAR IS REQUIRED.

**OPERATING INSTRUCTIONS**

**⚠ WARNING ONLY TRAINED PERSONNEL ARE TO OPERATE THIS TOOL.**

1. TO ENSURE TOOL IS OPERATING PROPERLY, PERFORM FOLLOWING STEPS AT START OF EACH SHIFT.
  - MAKE SURE TOOL MOVES UP AND DOWN FREELY WHILE HANGING FROM BALANCER OVERHEAD.
  - WITH POWER TO TOOL TURNED ON, TEST TRIGGER FOR PROPER OPERATION.
  - DEPRESS EACH TRIGGER SEPARATELY. TOOL SHOULD NOT ACTIVATE. DEPRESS BOTH TRIGGERS. TOOL SHOULD ACTIVATE.
  - IF TOOL HAS "ANTI-TIE DOWN" OPTION, BOTH TRIGGERS MUST BE DEPRESSED SIMULTANEOUSLY FOR TOOL TO ACTIVATE.
2. TO PERFORM WORK, HOLD TOOL FIRMLY AT BOTH HANDLES. SQUEEZE TRIGGERS TO ACTIVATE TOOL.
3. POSITION TOOL AND PERFORM CUTTING OPERATION. DESIGNED TO REMOVE HORN COMPLETELY WITH THE ADJACENT SKULL SECTION.
4. CUTTING DEPTH 4 ½".
5. ONE OPERATOR CAN HANDLE IN EXCESS OF 200 BEFF PER HOUR.

**MAINTENANCE**

**⚠ WARNING ONLY TRAINED AND QUALIFIED PERSONNEL ARE TO PERFORM MAINTENANCE AND SERVICE TO THIS TOOL.**

**THE COMPRESSED AIR DISTRIBUTION SYSTEM MUST BE LARGE ENOUGH TO SUPPLY AN ADEQUATE VOLUME OF CLEAN AND DRY COMPRESSED AIR TO THE TOOL.**

1. MAKE ALL NECESSARY LINE CONNECTIONS TO THE TOOL.
  2. AN AIR FILTER-REGULATOR-LUBRICATOR (PART NO. 7200030) MUST BE INSTALLED IN AIR SUPPLY FOR EACH TOOL.
3. FILL LUBRICATOR WITH KENTMASTER AIR MIST OIL (PART NO. 7903050). SET DRIP RATE ACCORDING TO INSTRUCTIONS SUPPLIED. TURN ADJUSTMENT ON SIGHT FEED DOME TO INCREASE/DECREASE OIL DELIVERY. MONITOR THE DEVICE BEING LUBRICATED AND READJUST IF NEEDED.
4. TOOL REQUIRES GREASING AT START OF EACH SHIFT. GREASE FOUR (4) LOCATIONS USING KENTMASTER GREASE GUN (PART NO. 4501470) AND GREASE (PART NO. 7903070).
  5. TOOL REQUIRES 40 S.C.F.M. OF AIR @ 90 P.S.I. AIR PRESSURE.
6. FLUSH AIR MOTOR AT END OF EACH DAY'S USE BY SQUIRTING A FEW SQUIRTS OF KENTMASTER AIR OIL MIST (PART 7903050) DIRECTLY INTO THE AIR INLET PORT. RUN TOOL A FEW SECONDS TO COAT AND PROTECT THE AIR MOTOR AND INTERNAL PARTS OF TOOL.

**BLADE REMOVAL AND CLEANING.**

**⚠ WARNING**

**ALWAYS DISCONNECT POWER SUPPLY FROM TOOL BEFORE INSTALLING OR REMOVING BLADE FROM TOOL.**

**⚠ WARNING**

**ALWAYS WEAR WIRE MESH GLOVES WHEN INSTALLING OR REMOVING BLADE FROM TOOL.**

1. USE WRENCH (ITEM NO. 3) TO REMOVE COLLAR (ITEM NO. 1, FIG. NO. 1).
2. OPEN BLADE GUARD (ITEM NO. 4).
3. REMOVE BLADE (ITEM NO. 2, FIG. NO. 1).
4. CLEAN ALL PARTS REMOVED WITH SOAP AND WATER.
5. SHARPEN OR REPLACE BLADES WHEN NECESSARY.
6. REASSEMBLE IN REVERSE ORDER.
7. BLADE MAY BE STERILIZED WHILE IN MACHINE.

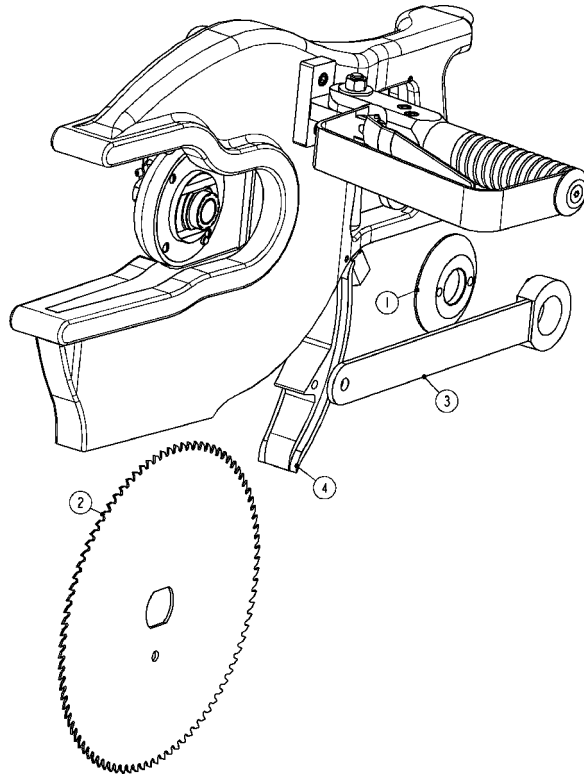

**Figure 1 MODEL AL – BLADE REPLACEMENT**

**SERVICE**

1. KEEP GOOD RECORDS OF ALL SERVICE ACTIVITY AND INCLUDE TOOL IN PREVENTIVE MAINTENANCE PROGRAM.
2. USE ONLY GENUINE KENTMASTER REPLACEMENT PARTS TO ASSURE PROPER PERFORMANCE OF TOOL.
3. CONTACT THE KENTMASTER SUPPLIER NEAREST YOU FOR PARTS AND CUSTOMER SERVICE INFORMATION.

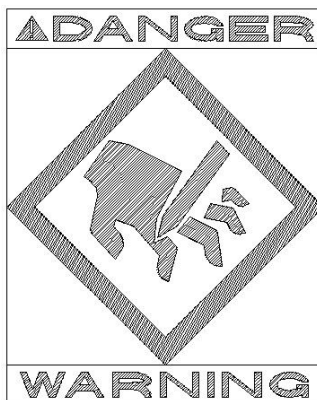

**PARTS BOOK**

**MAIN ASSEMBLY**

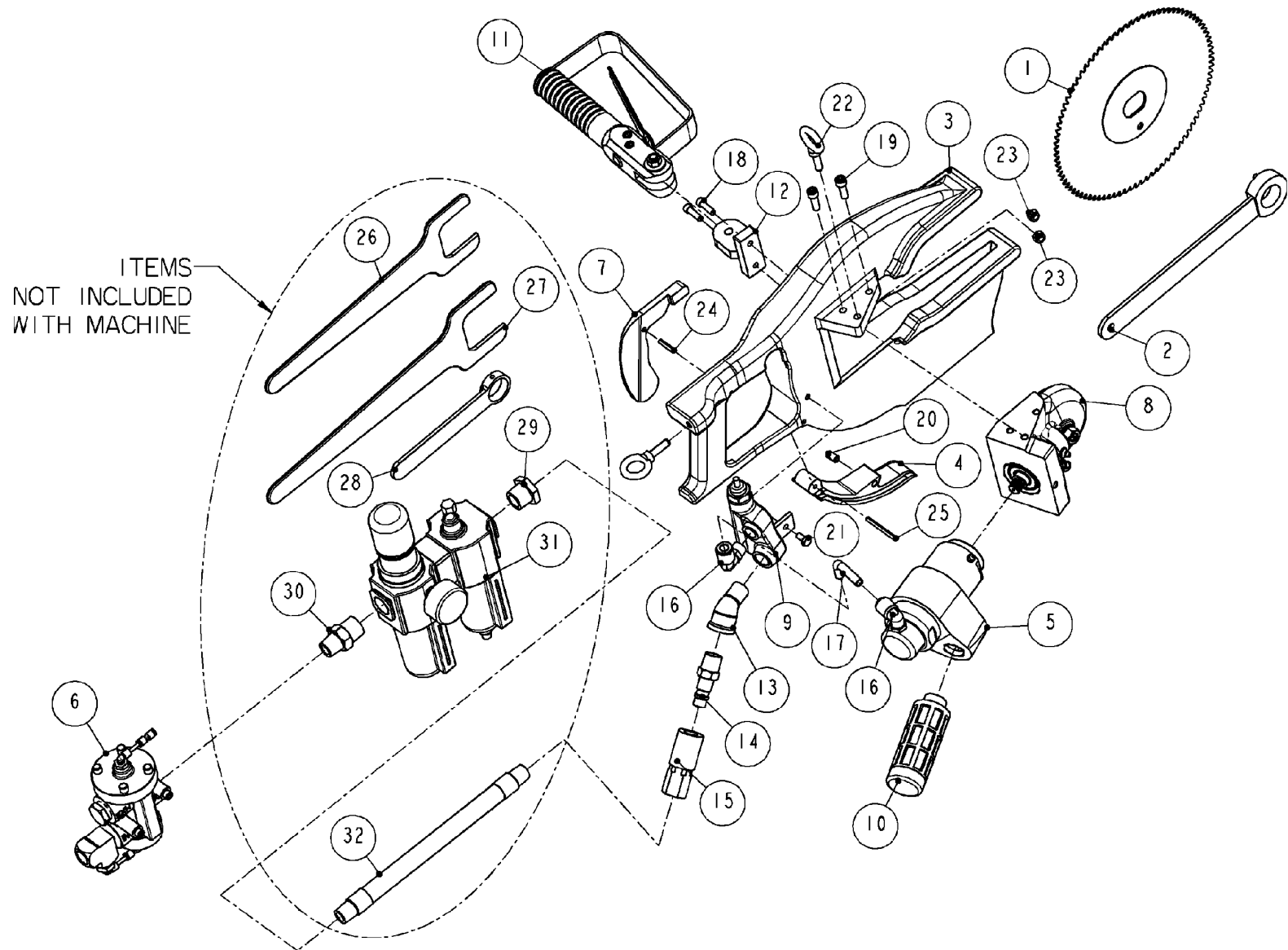

**Figure 2 MODEL "AL" – MAIN ASSEMBLY**

<b>6002000: "AL" LEG CUT-OFF AIR SAW</b>			
<b>ITEM</b>	<b>PART #</b>	<b>DESCRIPTION</b>	<b>QTY</b>
1	4000130	10" SAW BLADE, 90 TEETH - THIN RIM	1
2	4501610	WRENCH	1
3	6000920	FRAME	1
4	6000980	GUARD BLADE	1
5	6001000	AIR MOTOR & GEAR CASE ASS'Y, HIGH SPEED	1
6	6001605	POPPET VALVE ASSEMBLY	1
7	6001740	TRIGGER	1
8	6001750	GEAR NOSE HOUSING ASS'Y	1
9	6001790	AIR VALVE ASSEMBLY	1
10	6330160	MUFFLER	1
11	6600530	AIR HANDLE - FRONT	1
12	6609650	HANDLE BRACKET	1
13	7000540	STREET ELBOW	1
14	7034060	MALE QUICK CONNECT	1
15	7034260	FEMALE SOCKET	1
16	7036450	ELBOW	2
17	7300756	TUBE	1
18	8211070	SCREW	2
19	8213080	SCREW	2
20	8349640	BALL PLUNGER	1
21	8411040	SCREW	1
22	8463070	SHOULDER EYE BOLT	2
23	8504110	NUT	2
24	8613160	PIN	1
25	8613320	PIN	1
26	4501300	WRENCH- AIRMOTOR, GEAR CASE - <b>OPTIONAL</b>	1
27	4501390	WRENCH- AIRMOTOR HOUSING - <b>OPTIONAL</b>	1
28	6001420	WRENCH PINION - <b>OPTIONAL</b>	1
29	7002450	<b>BUSHING - OPTIONAL</b>	1
30	7002680	<b>ADAPTER - OPTIONAL</b>	1
31	7200030	<b>REGULATOR/FILTER/LUBRICATOR - OPTIONAL</b>	1
32	7310040	<b>AIR HOSE - OPTIONAL</b>	1

**MODEL "AL" WITH TWO TRIGGERS (FRONT HANDLE #6600530) REQUIRES POPPET VALVE (#6001605).  
AN AIR FILTER-REGULATOR-LUBRICATOR (#7200030) MUST BE INSTALLED IN AIR SUPPLY FOR EACH TOOL.**

**Figure 3 BOM FOR MODEL "AL"**

**GEAR NOSE ASSEMBLY**

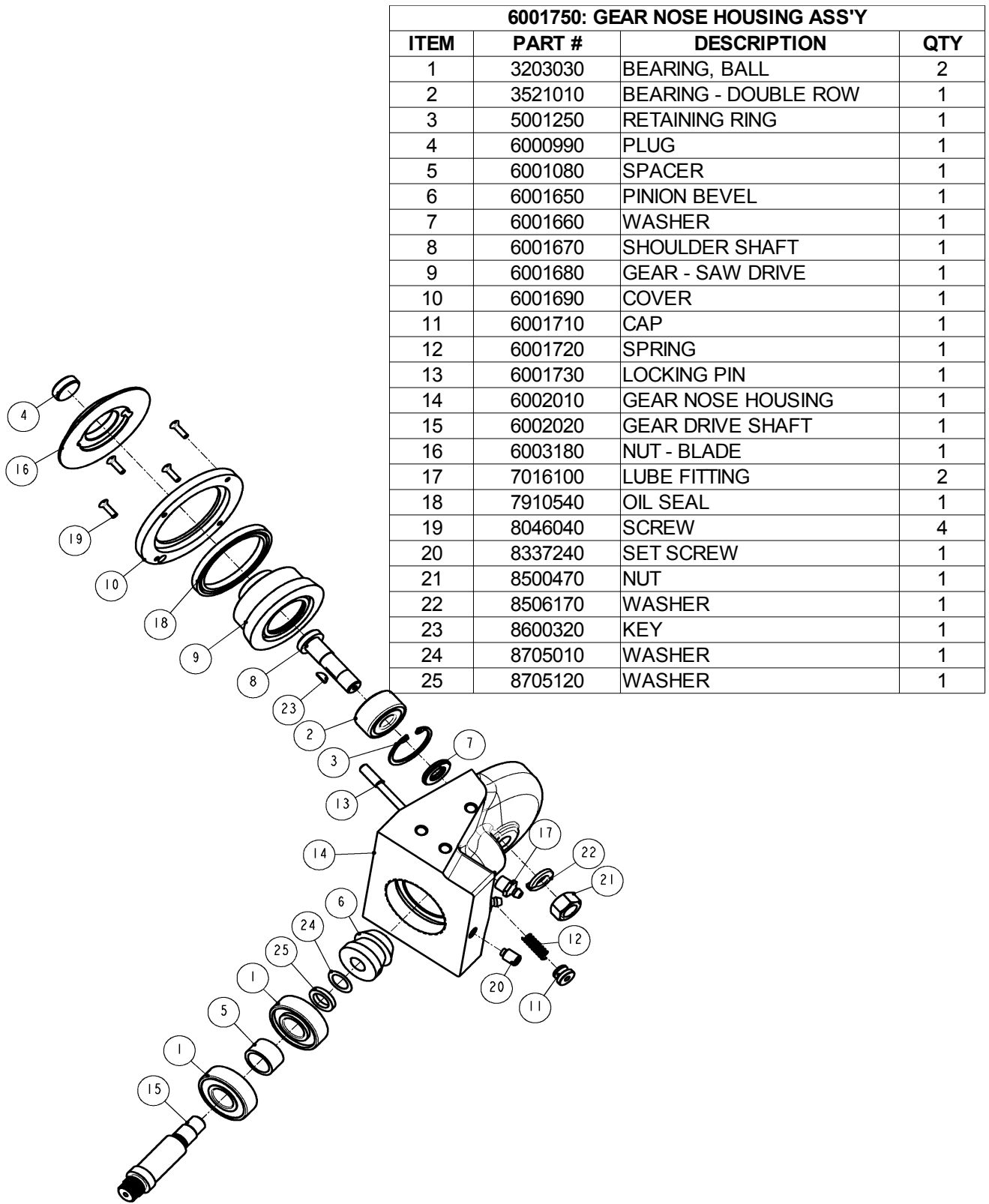

**Figure 4 GEAR-NOSE ASSEMBLY**

**KENTMASTER MFG. CO., INC.** 1801 SOUTH MOUNTAIN AVE., MONROVIA, CALIFORNIA 91016 UNITED STATES OF AMERICA  
 ☎ TELEPHONE: (626) 359-8888 FAX: (626) 303-5151

**GEAR HOUSING DISASSEMBLY**

1. REMOVE (1) NUT, ITEM 21 (FIGURE 4).
2. FROM REAR OF NOSE, ITEM 14, REMOVE COVER, ITEM 10.
3. FROM REAR OF NOSE, ITEM 14, PRESS OUT SHAFT, ITEM 8, WITH GEAR AND BEARING, NEXT.
4. REMOVE RETAINING RING, ITEM 3.
5. FROM FRONT FACE OF NOSE, ITEM 14, PRESS OUT GEAR DRIVE SHAFT AND PINION, ITEMS 15 & 6.
6. USING PINION WRENCH (OPTIONAL), ITEM 28 (FIGURE 2), REMOVE PINION, ITEM 6 (FIGURE 4).

**GEAR HOUSING REASSEMBLY**

1. CLEAN AND LUBRICATE ALL PARTS PRIOR TO REASSEMBLY.
2. REASSEMBLE PARS IN REVERSE ORDER.

**AIR MOTOR & GEAR CASE ASSEMBLY**

6001000: AIR MOTOR & GEAR CASE ASS'Y			
ITEM	PART	DESCRIPTION	QTY
1	6000940	DEFLECTOR	1
2	6001010	GEAR CASE ASSEMBLY	1
3	6001480	AIR MOTOR ASSEMBLY	1
4	7680360	O-RING	2
5	8311030	SET SCREW	1

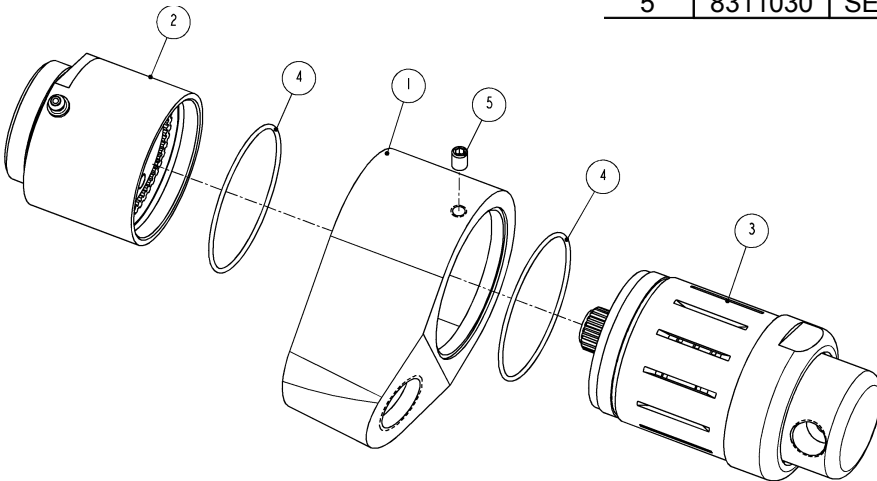

**Figure 5 AIR MOTOR AND GEAR CASE ASSEMBLY**



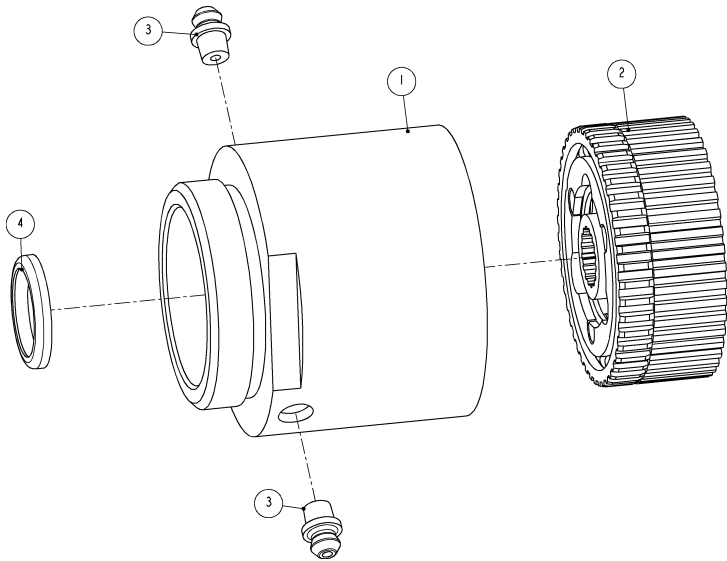

6001010: GEAR CASE ASSEMBLY			
ITEM	PART #	DESCRIPTION	QTY
1	6000860	GEAR CASE	1
2	6001030	GEAR CAGE	1
3	7017110	GREASE FITTING	2
4	7774100	SEAL	1

**Figure 6 GEAR CASE ASSEMBLY**

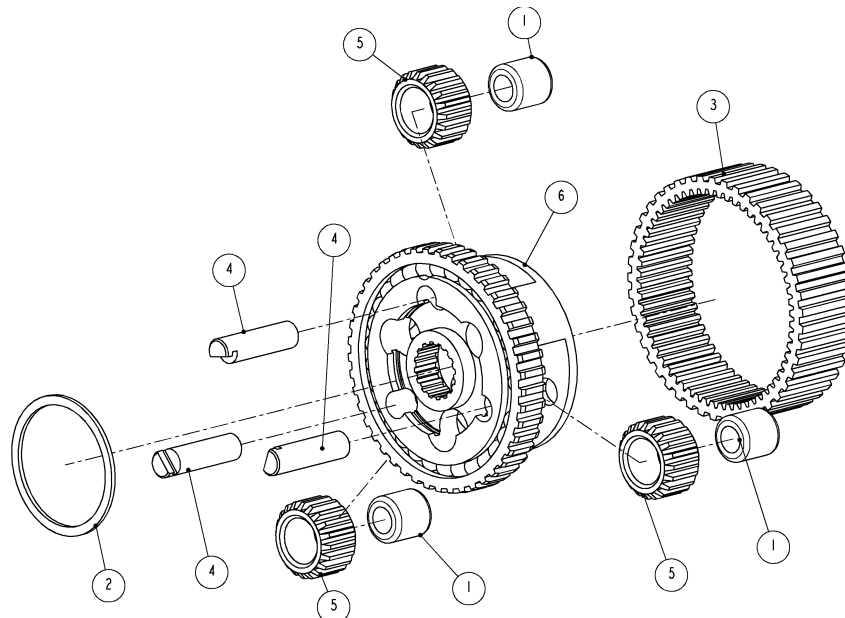

6001030: GEAR CAGE ASSEMBLY			
ITEM	PART #	DESCRIPTION	QTY
1	3700470	NEEDLE BEARING	3
2	5601250	RETAINING RING	1
3	6000790	RING GEAR	1
4	6001040	PIN	3
5	6001050	IDLER GEAR	3
6	6001060	GEAR CAGE AND SPLINE RING ASSEMBLY	1

**Figure 7 GEAR CAGE ASSEMBLY**

**GEAR CASE AND AIRMOTOR DISASSEMBLY**

1. LOOSEN SET SCREW, ITEM 5 (FIGURE 5).
2. USIN WRENCH (OPTIONAL), ITEM 26 (FIGURE 2), REMOVE CASE, ITEM 2 (FIGURE 5).
3. TO DISASSEMBLE GEAR CAGE ASSEMBLY:
  - REMOVE RETAINING RING, ITEM 2 (FIGURE 7).
  - PRESS OUT PINS (3) AND BEARINGS (3), ITEMS 4 AND 1 (FIGURE 7).
4. SLIDE DEFLECTOR, ITEM 1 (FIGURE 5), OFF HOUSING, ITEM 3 (FIGURE 5).
5. SLIDE AIR MOTOR OUT OF HOUSING, ITEM 2 (FIGURE 8).
6. PULL GEAR, ITEM 11 (FIGURE 8), OUT OF AIR MOTOR.
7. PULL PLATES, ITEMS 9 (FIGURE 8), OFF CYLINDER, ITEM 8 (FIGURE 8).

**GEAR CASE AND AIRMOTOR REASSEMBLY**

1. CLEAN AND LUBRICATE ALL PARTS PRIOR TO REASSEMBLY.
2. REASSEMBLE ALL PARTS IN REVERSE ORDER.
3. HAND TIGHTEN CASE, ITEM 2 (FIGURE 5), ONTO HOUSING, ITEM 3 (FIGURE 5).
4. ATTACH AIR TO TOOL. WITH TOOL ACTIVATED, TIGHTEN WITH A WRENCH, CASE ONTO HOUSING. THIS HELPS MAINTAIN THE ALIGNMENT OF AIRMOTOR TO GEAR CASE ASSEMBLY. DISCONNECT AIR SUPPLY.

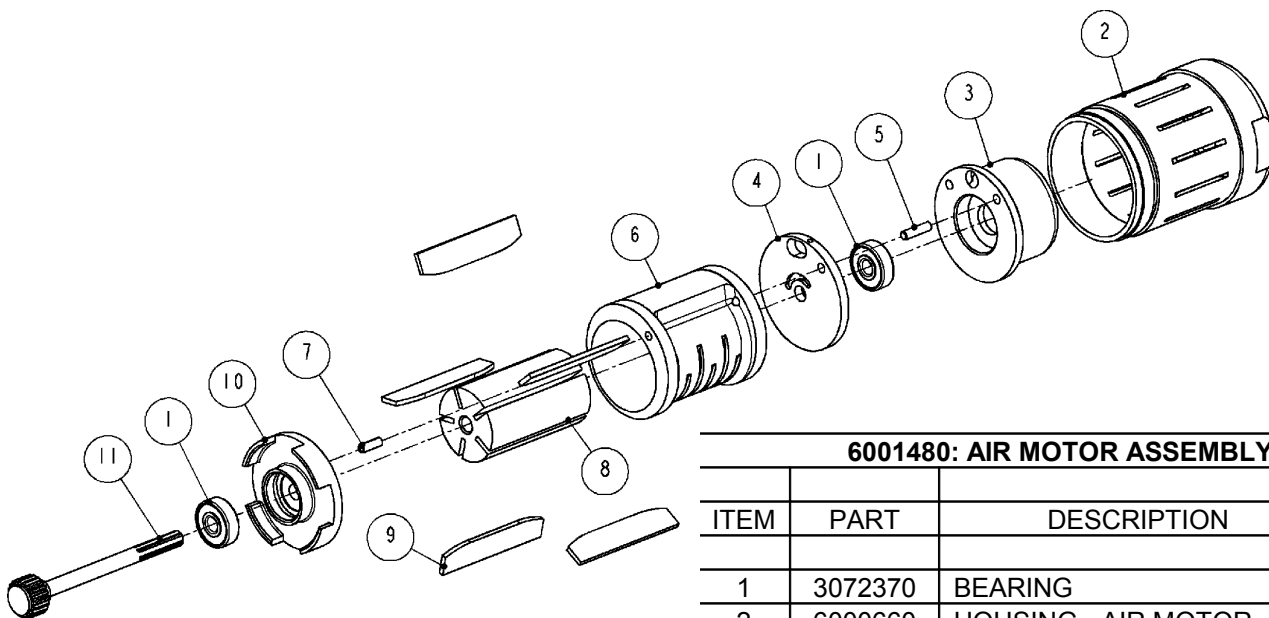
**6001480: AIR MOTOR ASSEMBLY**

ITEM	PART	DESCRIPTION	QTY
1	3072370	BEARING	2
2	6000660	HOUSING - AIR MOTOR	1
3	6000680	SHORT HEAD, AIR MOTOR	1
4	6000700	UPPER END PLATE	1
5	6000710	PIN	1
6	6000720	CYLINDER	1
7	6000730	PIN	1
8	6000740	ROTOR	1
9	6000750	ROTOR BLADES (SET OF 5)	5
10	6000760	LOWER END PLATE	1
11	6001020	LONG GEAR SPINDLE	1

**Figure 8 AIR MOTOR ASSEMBLY**

**HANDLE ASSEMBLY**

<b>6600530: AIR HANDLE - FRONT</b>			
ITEM	PART #	DESCRIPTION	QTY
1	6300770	VALVE PLUG	1
2	6541690	GUARD	1
3	6541720	RETAINER	1
4	6600340	HANDLE	1
5	6600350	BUSHING	1
6	6600360	VALVE STEM	1
7	6600500	LEVER	1
8	7000010	PLUG	2
9	7036510	ELBOW	2
10	7680080	O-RING	1
11	7680140	O-RING	1
12	8241050	SCREW	1
13	8415160	SCREW	1
14	8500150	NUT	1
15	8505160	WASHER	1
16	8620080	PIN	1
17	8890010	SPRING	1

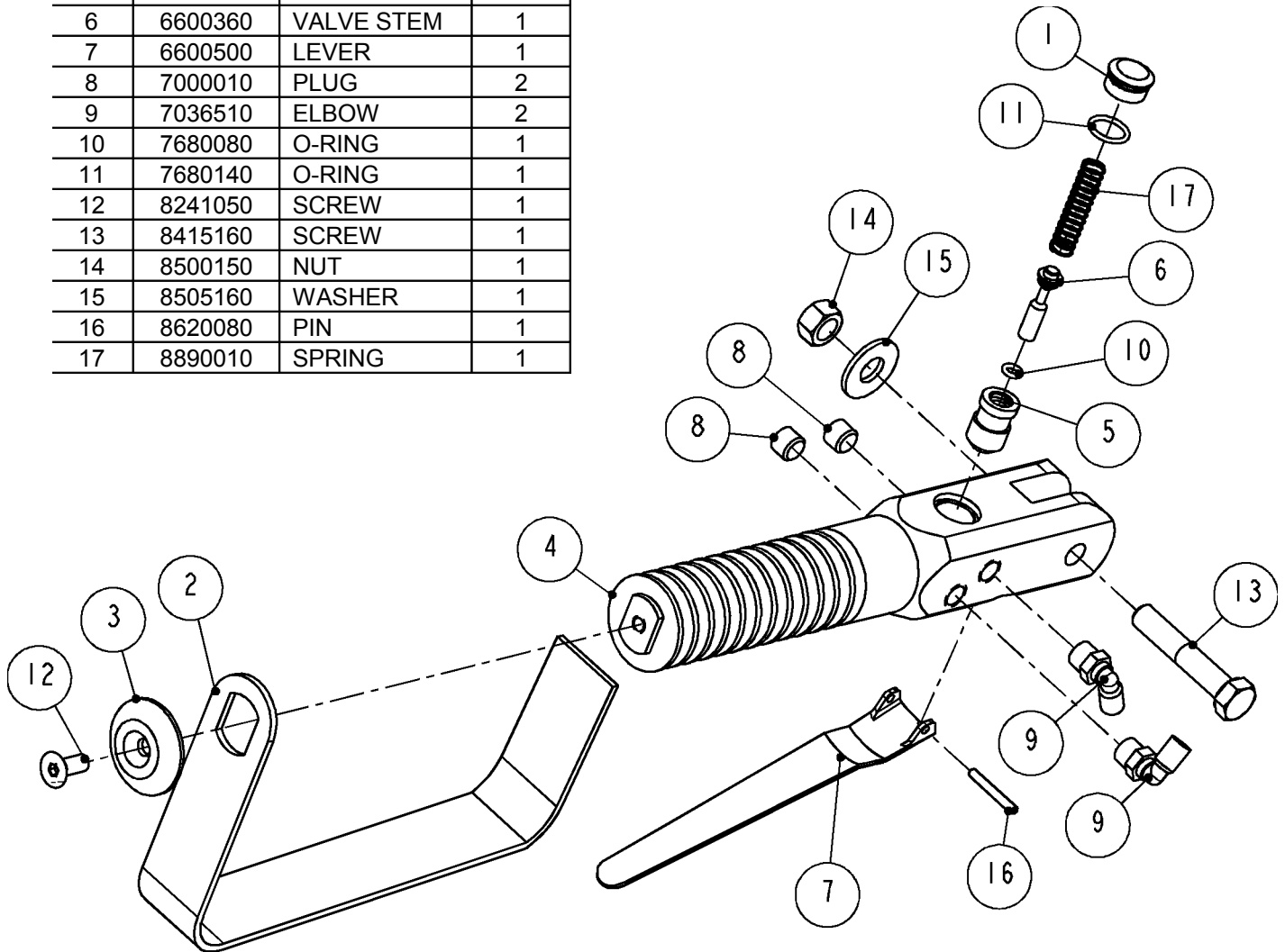

**FRONT HANDLE WITH AIR SWITCH (#6600530) REQUIRES POPPET VALVE (#6001605).**

**Figure 9 FRONT HANDLE WITH AIR SWITCH**

**AIR VALVE ASSEMBLY**

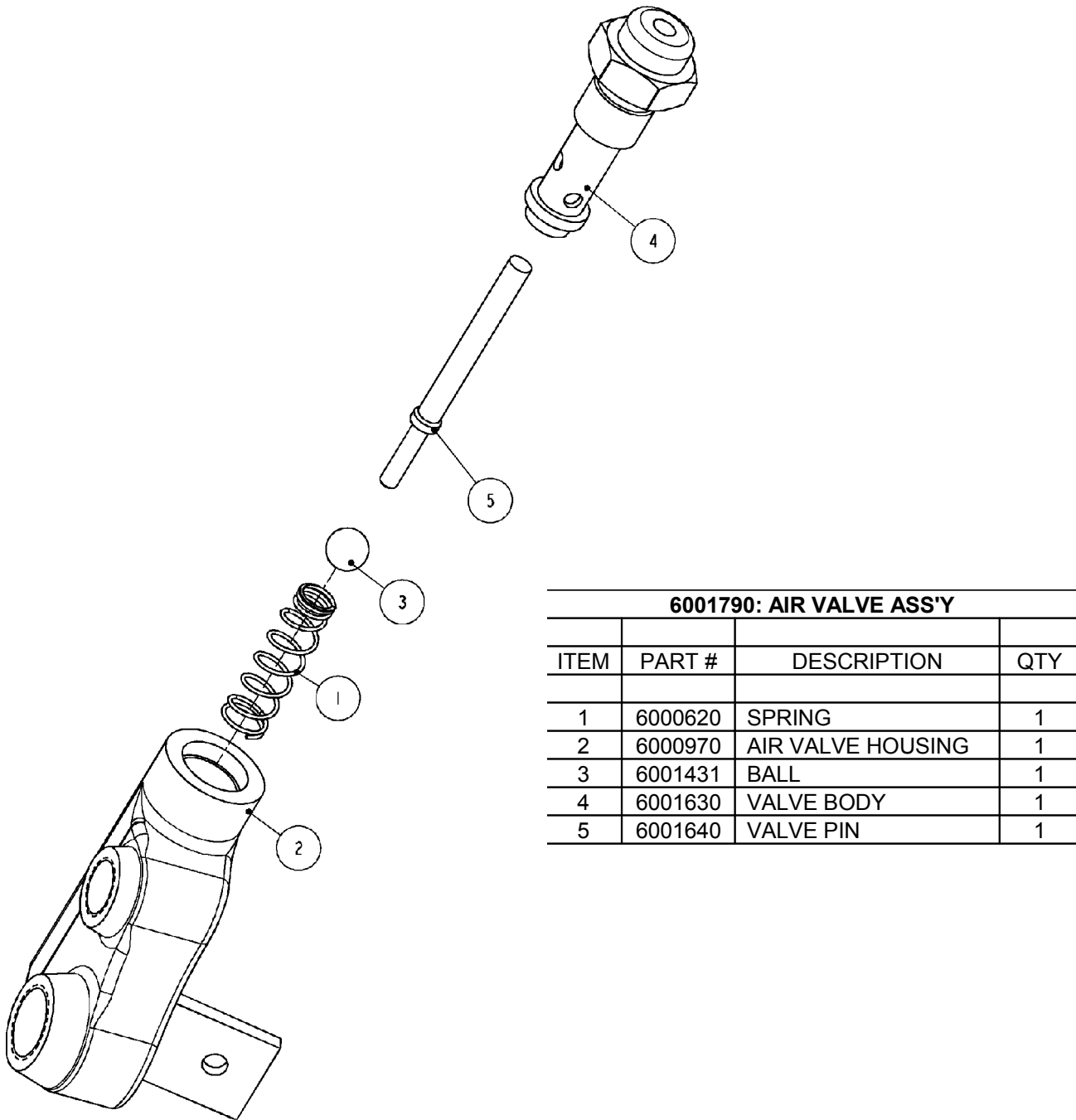

6001790: AIR VALVE ASS'Y			
ITEM	PART #	DESCRIPTION	QTY
1	6000620	SPRING	1
2	6000970	AIR VALVE HOUSING	1
3	6001431	BALL	1
4	6001630	VALVE BODY	1
5	6001640	VALVE PIN	1

**Figure 10 AIR VALVE ASSEMBLY**

**POPET VALE ASSEMBLY**

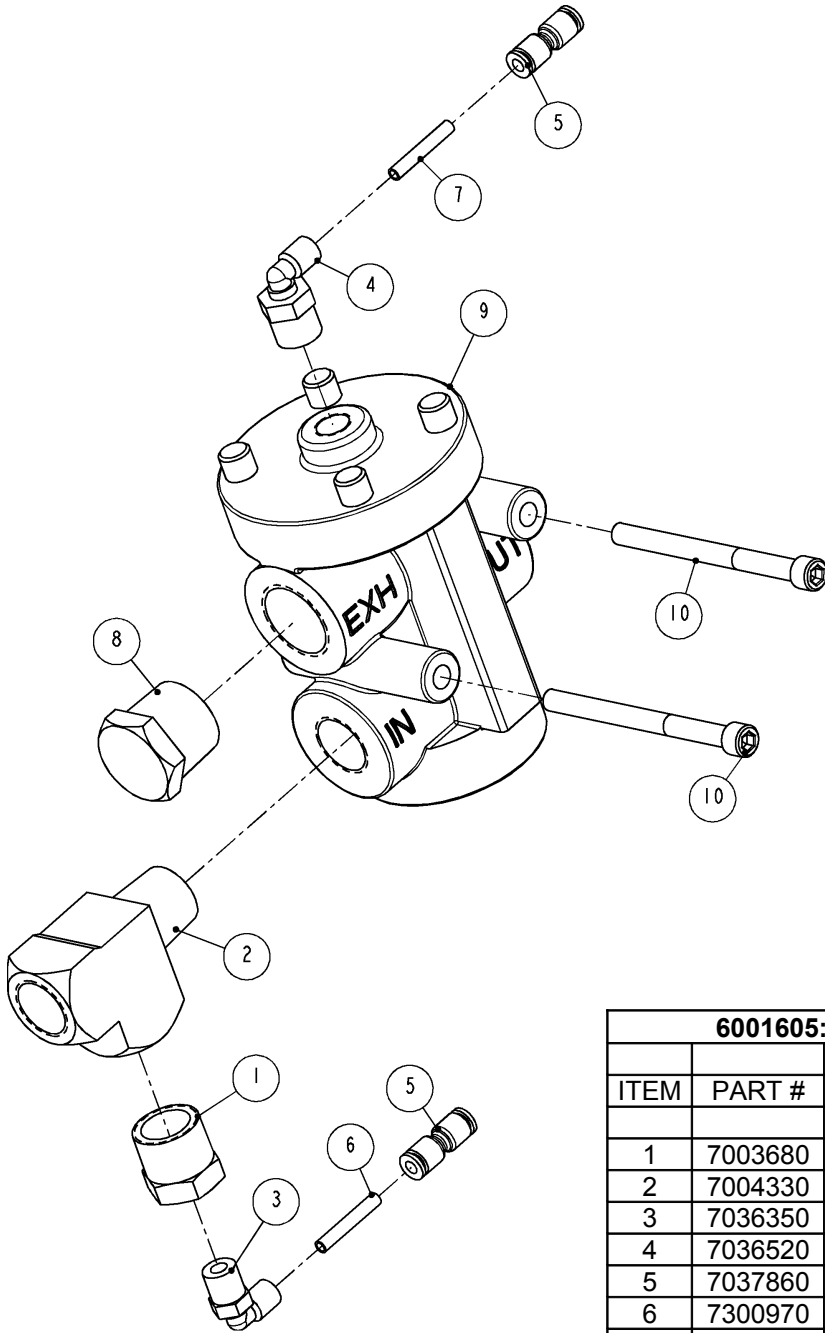

6001605: POPPET VALVE ASSEMBLY			
ITEM	PART #	DESCRIPTION	QTY
1	7003680	BUSHING	1
2	7004330	TEE, STREET	1
3	7036350	ELBOW	1
4	7036520	ELBOW	1
5	7037860	UNION	2
6	7300970	RED AIR TUBE	1
7	7300980	GREEN AIR TUBE	1
8	7802050	BREATHER VENT FILTER	1
9	7802500	POPET VALVE	1
10	8211240	SCREW	2

**POPET VALVE IS USED WITH MODEL "AL" WITH TWO TRIGGERS.**

**Figure 11 POPPET VALVE ASSEMBLY**

**WIRING DIAGRAM**

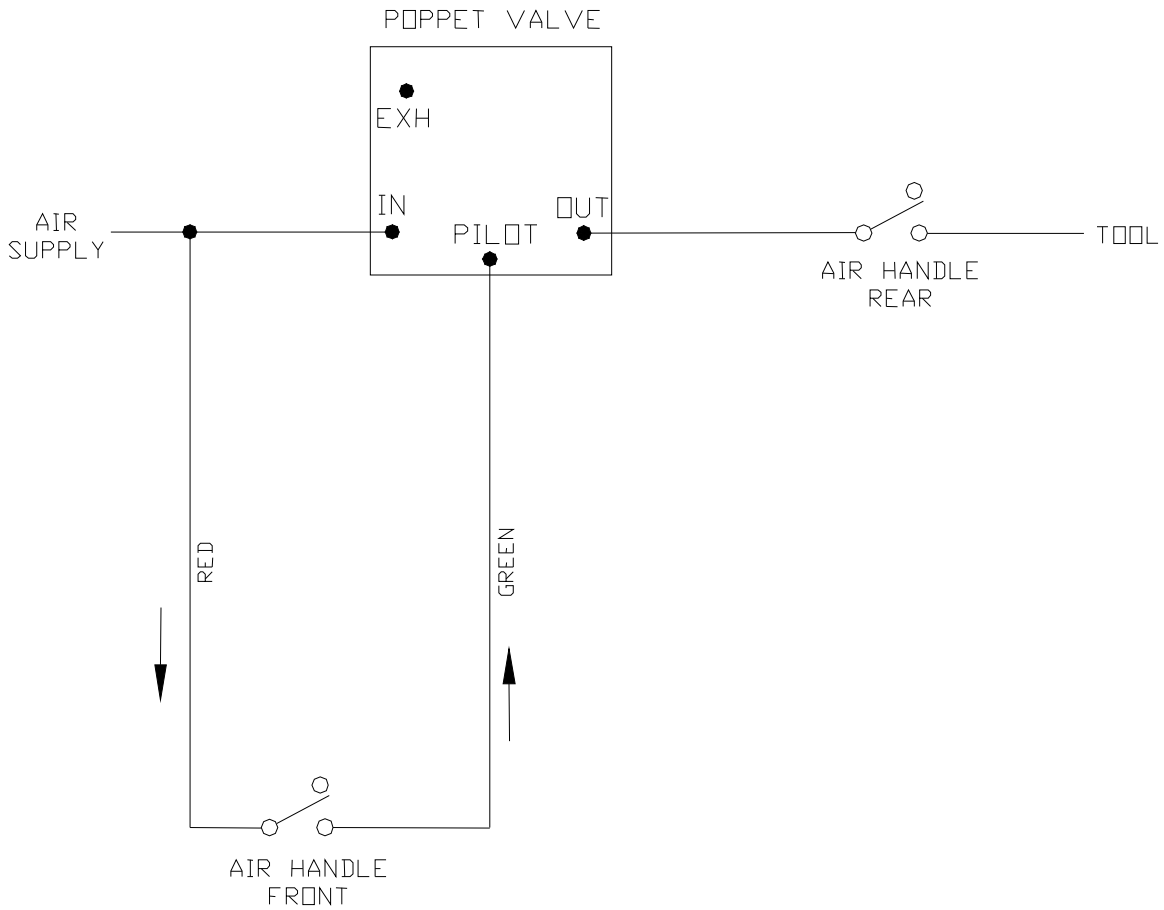

This wiring diagram is for model “AL” with two triggers. As shown on the diagram above, two triggers option requires poppet valve (Kentmaster part No. 6001605).

**Figure 12 WIRING DIAGRAM**

[ENGLISH]

## GENERAL INFORMATION

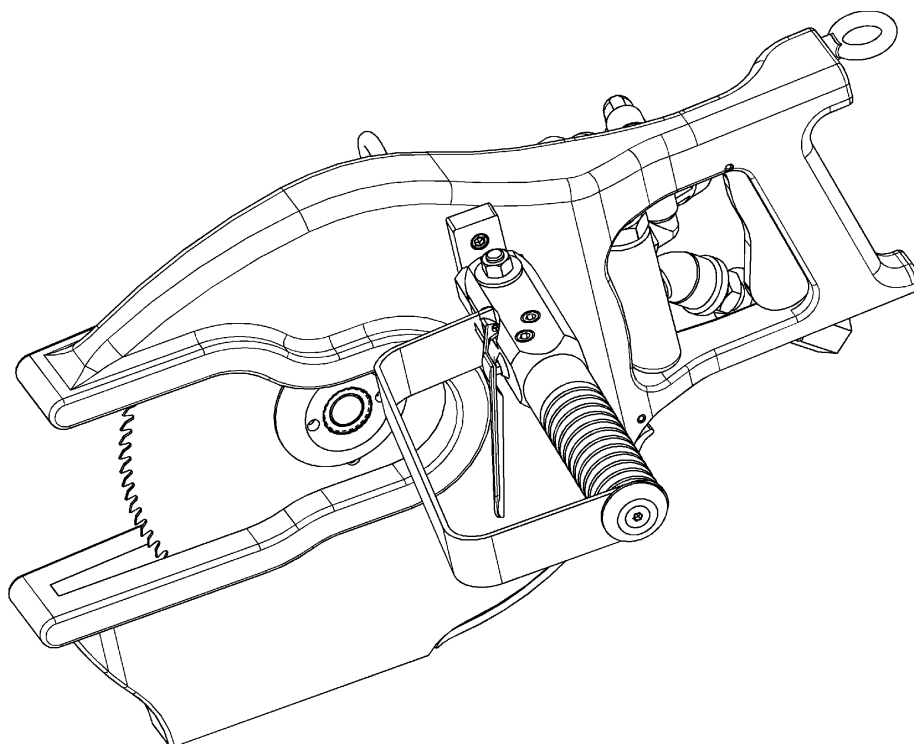

### MODELS

## **LEG CUT-OFF AIR SAW "AL"**

### SERVICE CENTERS

**KENTMASTER LTD. (U.K)**  
16 AVONBANK INDUSTRIAL CENTRE  
WEST TOWN ROAD  
AVONMOUTH - BRISTOL BS11 9DE  
UNITED KINGDOM

☎ **TELEPHONE: ++ 44- (0) 117- 9235035**  
**FAX: ++ 44- (0) 117- 9829010**

**KENTMASTER MFG. CO., INC.**  
1801 SOUTH MOUNTAIN AVE.  
MONROVIA, CALIFORNIA 91016  
UNITED STATES OF AMERICA

☎ **TELEPHONE: (626) 359-8888**  
**FAX: (626) 303-5151**

**NOTICE TO EMPLOYER AND PURCHASER OF TOOL**  
**NOTICE TO SAFETY DIRECTOR**

**You have purchased a powerful tool that, if misused, can cause severe injury and harm to your employees. You must instruct your employees in the safe and proper use of this tool and to follow the safety procedures and instructions that have been supplied by the manufacturer of this tool. Please follow the following instructions.**

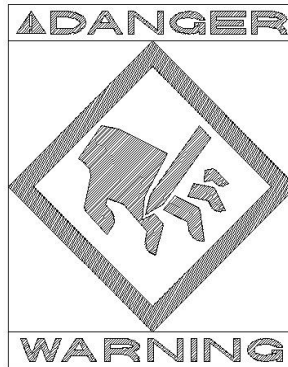

1. Instruct tool operators to test the tool each day before using it to be sure it does not malfunction. Remove and repair any tool that malfunctions.
2. Instruct tool operators to immediately stop using a tool that malfunctions or is defective.
3. Instruct personnel to immediately remove all tools that malfunction. Be sure to disconnect tool from power supply.
4. Instruct all personnel to stay clear of tool, and not to stand or walk in front of, or next to tool when in use.
5. Point out to all personnel the dangers related to the misuse of tool and the importance of following safety procedures and instructions.
6. Do not make, or allow others to make, alterations or modifications to this tool. Replace all lost or illegible labels.
7. Follow all safety, installation and maintenance instructions provided with this tool. Establish proper safety procedures in accordance with local and national requirements to prevent accidental energizing of tool that can cause injuries.
8. If this tool is sold or change in ownership takes place, you must provide the new owner all safety instructions, notices and maintenance instructions you were originally provided. You can obtain additional copies of the instructions from Kentmaster, free of charge upon request.
9. Give copies of instructions to:
  - (A) Tool Operators**
  - (B) Maintenance Supervisor**
  - (C) Clean-up Supervisor**



## **GENERAL INFORMATION**

COVERING: SAFETY PRECAUTIONS AND PLACING INTO SERVICE

### **LEG CUT-OFF AIR SAW “AL”**

**READ THIS MANUAL CAREFULLY BEFORE INSTALLING, OPERATING OR SERVICING THIS TOOL**

IT IS THE RESPONSIBILITY OF THE EMPLOYER TO PLACE THIS INFORMATION INTO THE HANDS OF THE OPERATOR.

### **PLACING INTO SERVICE**

 **WARNING**

= Hazards or unsafe practices which could result in severe personal injury, death or substantial property damage.

 **CAUTION**

= Hazards or unsafe practices which could result in minor personal injury, product or property damage.

 **NOTICE**

= Important installation, operation or maintenance information.

 **WARNING**

Installation, adjustment repair and maintenance of this tool must be made by trained and qualified personnel.

 **WARNING**

Always disconnect power supply from tool before:  
(A) Installing or removing blade from tool.  
(B) Making repairs or adjustments to the tool.  
(C) performing maintenance or cleanup work.

## INSTALLATION INSTRUCTIONS

### MAINTENANCE

**⚠ WARNING** ONLY TRAINED AND QUALIFIED PERSONNEL ARE TO PERFORM MAINTENANCE AND SERVICE TO THIS TOOL.

**THE COMPRESSED AIR DISTRIBUTION SYSTEM MUST BE LARGE ENOUGH TO SUPPLY AN ADEQUATE VOLUME OF CLEAN AND DRY COMPRESSED AIR TO THE TOOL.**

1. MAKE ALL NECESSARY LINE CONNECTIONS TO THE TOOL.
2. AN AIR FILTER-REGULATOR-LUBRICATOR (PART NO. 7200030) MUST BE INSTALLED IN AIR SUPPLY FOR EACH TOOL.
3. FILL LUBRICATOR WITH KENTMASTER AIR MIST OIL (PART NO. 7903050). SET DRIP RATE ACCORDING TO INSTRUCTIONS SUPPLIED. TURN ADJUSTMENT ON SIGHT FEED DOME TO INCREASE/DECREASE OIL DELIVERY. MONITOR THE DEVICE BEING LUBRICATED AND READJUST IF NEEDED.
4. TOOL REQUIRES GREASING AT START OF EACH SHIFT. GREASE FOUR (4) LOCATIONS USING KENTMASTER GREASE GUN (PART NO. 4501470) AND GREASE (PART NO. 7903070).
5. TOOL REQUIRES 40 S.C.F.M. OF AIR @ 90 P.S.I. AIR PRESSURE.
6. FLUSH AIR MOTOR AT END OF EACH DAY'S USE BY SQUIRTING A FEW SQUIRTS OF KENTMASTER AIR OIL MIST (PART 7903050) DIRECTLY INTO THE AIR INLET PORT. RUN TOOL A FEW SECONDS TO COAT AND PROTECT THE AIR MOTOR AND INTERNAL PARTS OF TOOL.
7. A BALANCER IS REQUIRED FOR OPERATION AND USE OF THIS TOOL. WEIGHT OF TOOL MUST FALL WITHIN WEIGHT RANGE OF BALANCER.
8. INSTALL BALANCER ABOVE WORK AREA. BALANCER MUST HAVE SUFFICIENT VERTICAL TRAVEL SO OPERATOR CAN REACH ENTIRE WORK AREA WITH TOOL WITHOUT STRAIN.
9. ADJUST BALANCER ACCORDING TO THE OPERATOR'S PREFERENCE AND COMFORT.

**⚠ WARNING** WE STRONGLY SUGGEST THAT AN ADDITIONAL SAFETY CHAIN BE USED TO CHAIN BALANCER TO OVERHEAD TROLLEY. THIS ADDITIONAL MEASURE OF SAFETY WILL HELP REDUCE INJURIES.

### OPERATING INSTRUCTIONS

**⚠ WARNING** ONLY TRAINED PERSONNEL ARE TO OPERATE THIS TOOL.

1. HOLD TOOL FIRMLY AT BOTH TRIGGER HANDLES. SQUEEZE TRIGGERS SIMULTANEOUSLY TO ACTIVATE TOOL.
2. DO NOT EXERT EXCESSIVE PRESSURE. ALLOW TIME FOR THE TOOL TO CUT.

### SERVICE

1. KEEP GOOD RECORDS OF ALL SERVICE ACTIVITY AND INCLUDE TOOL IN YOUR PREVENTIVE MAINTENANCE PROGRAM.
2. USE ONLY GENUINE KENTMASTER REPLACEMENT PARTS TO ASSURE PROPER PERFORMANCE OF TOOL.
3. CONTACT THE KENTMASTER SUPPLIER NEAREST YOU FOR PARTS AND CUSTOMER SERVICE INFORMATION.

## Kentmaster Worldwide Location

Kentmaster Equipment (Aust) PTY.LTD.

Unit 2,24 Central Court  
Browns Plains Qld. 4118  
Australia

Telephone: (07) 3806-8400  
Fax: (07) 3806-7933  
[Australia@Kentmaster.com](mailto:Australia@Kentmaster.com)

---

Kentmaster do Brasil, Ltda.  
Av. Dr. Joao Teodoro No. 805  
Bairro De Vila Rezende  
13405-240 Piracicaba, SP,  
Brazil

Telephone #1: (019) 3 413 3113  
Telephone #2: (019)983-4973  
Fax: (019) 3 413 3113  
[Brazil@Kentmaster.com](mailto:Brazil@Kentmaster.com)

---

Kentmaster (IRL) LTD.  
Benamore, Dublin Road.  
Roscrea,  
CO, Tipperary,  
Ireland

Telephone: (353) 0505-23292  
Fax: (353) 0505-23299  
[Ireland@Kentmaster.com](mailto:Ireland@Kentmaster.com)

---

Kentmaster Equipment (NZ) LTD.  
5 Cooper Street  
Havelock North  
New Zealand

Telephone #1: (64) 6 8777 857  
Telephone #2: 0800 KENTMASTER  
Fax: (64) 6 8777 858  
[NewZealand@Kentmaster.com](mailto:NewZealand@Kentmaster.com)

Kentmaster South Africa (PTY) LTD.  
Johannesburg - S. Africa  
Unit 54 Sunnyrock Park  
Sunrock Close, Germiston  
South Africa

Telephone: (27) 11-455-3748  
Fax: (27) 11-455-3749  
[SouthAfrica@Kentmaster.com](mailto:SouthAfrica@Kentmaster.com)

---

Kentmaster (UK ) LTD.  
Unit 16 Avonbank Ind. Centre  
West Town Rd, Avonmouth-Bristol,  
BS11 9DE  
England

Telephone: (44) 117-923-5035  
Fax: (44)-117-932-9010  
[UK@Kentmaster.com](mailto:UK@Kentmaster.com)

---

Kentmaster Mfg. Co., Inc.  
1801 South Mountain Ave.  
Monrovia, CA, 91016  
USA

Telephone #1: (626) 359-8888  
Telephone #2: (800) 421-1477  
Fax: (626) 303-5151  
[info@Kentmaster.com](mailto:info@Kentmaster.com)

---

Kentmaster Omaha  
4417 South 139th Street  
Omaha, NE, 68137  
USA

Telephone #1: (402) 896-3355  
Telephone #2: (800) 367-3181  
Fax: (402) 896-3311  
[Omaha@Kentmaster.com](mailto:Omaha@Kentmaster.com)

**INDEX**

**OPERATING AND SAFETY INSTRUCTIONS**.....2  
     **OPERATING INSTRUCTIONS**.....3  
     **MAINTENANCE**.....3  
**SERVICE**.....4  
**PARTS BOOK**.....4  
     **MAIN ASSEMBLY**.....5  
     **GEAR NOSE ASSEMBLY**.....7  
         GEAR HOUSING DISASSEMBLY.....8  
         GEAR HOUSING REASSEMBLY.....8  
     **AIR MOTOR & GEAR CASE ASSEMBLY**.....8  
         GEAR CASE AND AIRMOTOR DISASSEMBLY.....10  
         GEAR CASE AND AIRMOTOR REASSEMBLY.....10  
     **HANDLE ASSEMBLY**.....11  
     **AIR VALVE ASSEMBLY**.....12  
     **POPET VALE ASSEMBLY**.....13  
     **WIRING DIAGRAM**.....14  
**NOTICE TO EMPLOYER AND PURCHASER OF TOOL**.....16  
**GENERAL INFORMATION**.....17  
     **INSTALLATION INSTRUCTIONS**.....18  
     **MAINTENANCE**.....18  
     **OPERATING INSTRUCTIONS**.....18  
     **SERVICE**.....18  
*Kentmaster Worldwide Location*.....19  
**INDEX**.....20  
**FIGURES - INDEX**.....20

**FIGURES - INDEX**

*Figure 1 MODEL AL – BLADE REPLACMENT*.....4  
*Figure 2 MODEL “AL” – MAIN ASSEMBLY*.....5  
*Figure 3 BOM FOR MODEL “AL”*.....6  
*Figure 4 GEAR-NOSE ASSEMBLY*.....7  
*Figure 5 AIR MOTOR AND GEAR CASE ASSEMBLY*.....8  
*Figure 6 GEAR CASE ASSEMBLY*.....9  
*Figure 7 GEAR CAGE ASSEMBLY*.....9  
*Figure 8 AIR MOTOR ASSEMBLY*.....10  
*Figure 9 FRONT HANDLE WITH AIR SWITCH*.....11  
*Figure 10 AIR VALVE ASSEMBLY*.....12  
*Figure 11 POPPET VALVE ASSEMBLY*.....13  
*Figure 12 WIRING DIAGRAM*.....14