

OPERATOR'S MANUAL

INCLUDING: OPERATION, INSTRUCTION, INSTALLATION, MAINTENANCE AND PARTSBOOK

IMPORTANT: READ THIS MANUAL CAREFULLY BEFORE INSTALLING, OPERATING OR SERVICING THIS TOOL.

SHEEP BRISKET SHEAR

TOOL DATA

MODEL: SBS-2

ASSEMBLY NO.: 6240500



TYPE: AIR / HYDRAULICALLY OPERATED

NET WEIGHT: 30 LBS (13.6 KG)



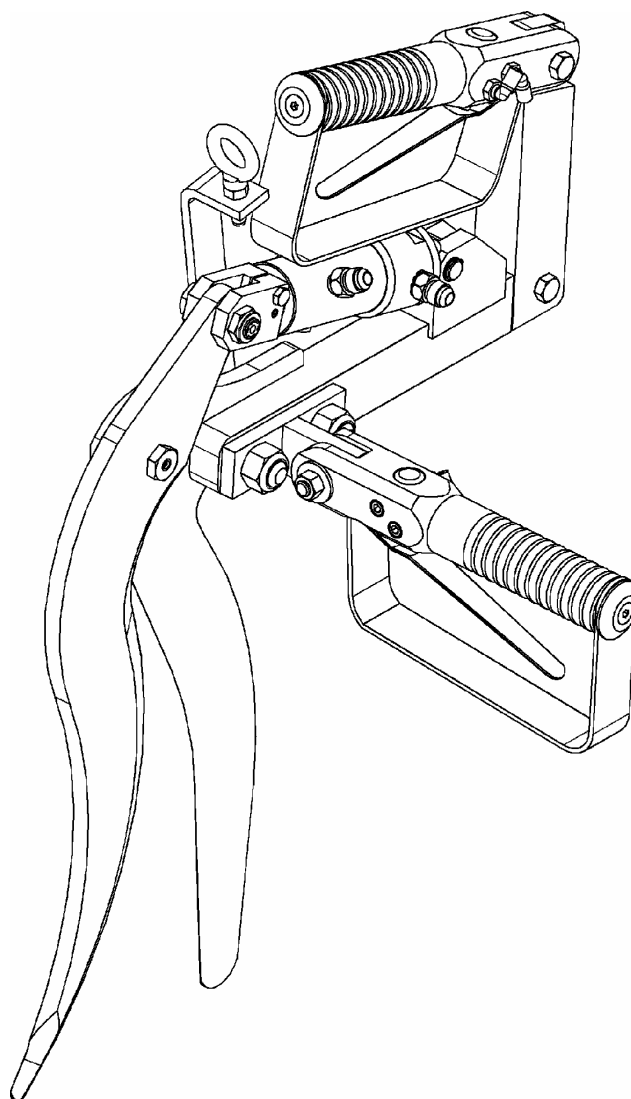











HYDRAULIC PRESSURE: 2000 P.S.I. MAXIMUM

INLET AIR PRESSURE: 90 P.S.I. (6-7 BARS)



 WARNING	= Hazards or unsafe practices which could result in severe personal injury, death or substantial property damage.
 CAUTION	= Hazards or unsafe practices which could result in minor personal injury, product or property damage.
 NOTICE	= Important installation, operation or maintenance information.

OPERATING AND SAFETY INSTRUCTIONS

-  **WARNING** DO NOT OPERATE THIS TOOL UNTIL YOU HAVE READ AND UNDERSTOOD THE SAFETY INSTRUCTIONS AND OPERATING MANUALS.
-  **WARNING** DO NOT OPERATE THIS TOOL UNTIL YOU HAVE RECEIVED TRAINING IN THE HANDLING, OPERATION AND USE OF THIS TOOL.
-  **WARNING** STOP USING A MALFUNCTIONING OR DEFECTIVE TOOL IMMEDIATELY. REPORT ANY PROBLEMS OR DEFECTS TO YOUR SUPERVISOR FOR REMOVAL OF THE TOOL FROM SERVICE.
-  **WARNING** DO NOT ATTEMPT TO REPAIR THE TOOL YOURSELF.
-  **WARNING** DO NOT ALLOW UNAUTHORIZED PERSONS TO USE TOOL.
-  **WARNING** REMOVE AND DISCONNECT POWER FROM THE TOOL WHEN TOOL IS LEFT UNATTENDED OR IS NOT IN USE.
-  **WARNING** NEVER TIE DOWN, BYPASS, ALTER OR MODIFY THE ACTIVATING SWITCHES OR TRIGGERS OF THIS TOOL.
-  **WARNING** NEVER MAKE ALTERATIONS OR MODIFICATIONS TO THIS TOOL.
-  **WARNING** BE CONSTANTLY AWARE AND ALERT FOR UNSAFE CONDITIONS AND REPORT THEM IMMEDIATELY TO YOUR SUPERVISOR.
-  **WARNING** NEVER PLACE YOUR HAND OR ANY PART OF YOUR BODY IN THE CUTTING PATH OF THE TOOL.
-  **WARNING** NEVER ALLOW ANYONE ELSE TO PLACE THEIR HANDS OR ANY PART OF THEIR BODY IN THE CUTTING PATH OF THE TOOL.
-  **WARNING** DO NOT ACTIVATE CONTROL SWITCHES OR TRIGGERS OF THIS TOOL UNLESS YOU INTEND TO TEST OR OPERATE THIS TOOL.
-  **WARNING** DO NOT USE THIS TOOL FOR ANY PURPOSE OTHER THAN IT'S INTENDED PURPOSE.
-  **CAUTION** WHEN OPERATING THIS TOOL WEAR THE PROTECTIVE GEAR AND SAFETY EQUIPMENT SUPPLIED TO YOU.
-  **WARNING** THE NOISE EMISSION (SOUND PRESSURE LEVEL) AT THE WORKSTATION MAY EXCEED 80 dB (A). EAR AND SOUND PROTECTION GEAR IS REQUIRED.

OPERATING INSTRUCTIONS

⚠ WARNING ONLY TRAINED PERSONNEL ARE TO OPERATE THIS TOOL.

1. TO ENSURE TOOL IS OPERATING PROPERLY, PERFORM FOLLOWING STEPS AT START OF EACH SHIFT:
 - MAKE SURE TOOL MOVES UP AND DOWN FREELY WHILE HANGING FROM BALANCER OVERHEAD.
 - WITH POWER TO TOOL TURNED ON, TEST TRIGGER FOR PROPER OPERATION.
 - DEPRESS EACH TRIGGER SEPARATELY. TOOL SHOULD NOT ACTIVATE. DEPRESS BOTH TRIGGERS. TOOL SHOULD ACTIVATE.
 - IF TOOL HAS "ANTI-TIE DOWN" OPTION, BOTH TRIGGERS MUST BE DEPRESSED SIMULTANEOUSLY FOR TOOL TO ACTIVATE.
2. TO PERFORM WORK, HOLD TOOL FIRMLY AT BOTH HANDLES. SQUEEZE TRIGGERS TO ACTIVATE TOOL.
3. POSITION TOOL AND PERFORM CUTTING OPERATION.

MAINTENANCE

⚠ WARNING ONLY TRAINED AND QUALIFIED PERSONNEL ARE TO PERFORM MAINTENANCE AND SERVICE TO THIS TOOL.

1. MAKE ALL NECESSARY LINE CONNECTIONS TO THE TOOL.
2. AN AIR FILTER-REGULATOR-LUBRICATOR (PART NO. 7200030) MUST BE INSTALLED IN AIR SUPPLY FOR EACH TOOL.
3. FILL LUBRICATOR WITH KENTMASTER AIR MIST OIL (PART NO. 7903050). SET DRIP RATE ACCORDING TO INSTRUCTIONS SUPPLIED. TURN ADJUSTMENT ON SIGHT FEED DOME TO INCREASE/DECREASE OIL DELIVERY. MONITOR THE DEVICE BEING LUBRICATED AND READJUST IF NEEDED.
4. TOOL REQUIRES 90 P.S.I. AIR PRESSURE.
5. TOOL REQUIRES GREASING AFTER EVERY SHIFT. GREASE USING KENTMASTER GREASE (PART NO. 7903070).

BLADE REMOVAL AND CLEANING.

⚠ WARNING ALWAYS DISCONNECT POWER SUPPLY FROM TOOL BEFORE INSTALLING OR REMOVING BLADE FROM TOOL.

⚠ WARNING ALWAYS WEAR WIRE MESH GLOVES WHEN INSTALLING OR REMOVING BLADE FROM TOOL.

TO REMOVE OR CHANGE BLADES (PROCEDURE NOT NECESSARY TO CLEAN BLADES):

1. REMOVE (2) BOLTS (ITEMS NO. 1)
2. REMOVE PINS AND NUTS (ITEM NO. 2 AND 3, FIG. NO. 1).
3. SLIDE OUT BLADES (ITEMS 4 AND 5).
4. CLEAN ALL PARTS REMOVED WITH SOAP AND WATER.
5. SHARPEN OR REPLACE BLADES WHEN NECESSARY.
6. REASSEMBLE IN REVERSE ORDER.

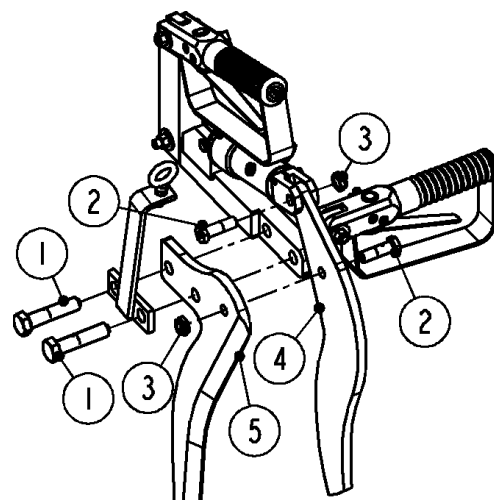
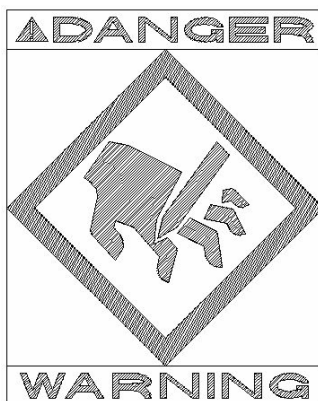

Figure 1 MODEL SBS-2 – BLADE REPLACEMENT

SERVICE

1. KEEP GOOD RECORDS OF ALL SERVICE ACTIVITY AND INCLUDE TOOL IN PREVENTIVE MAINTENANCE PROGRAM.
2. USE ONLY GENUINE KENTMASTER REPLACEMENT PARTS TO ASSURE PROPER PERFORMANCE OF TOOL.
3. CONTACT THE KENTMASTER SUPPLIER NEAREST YOU FOR PARTS AND CUSTOMER SERVICE INFORMATION.



PARTS BOOK

MAIN ASSEMBLY

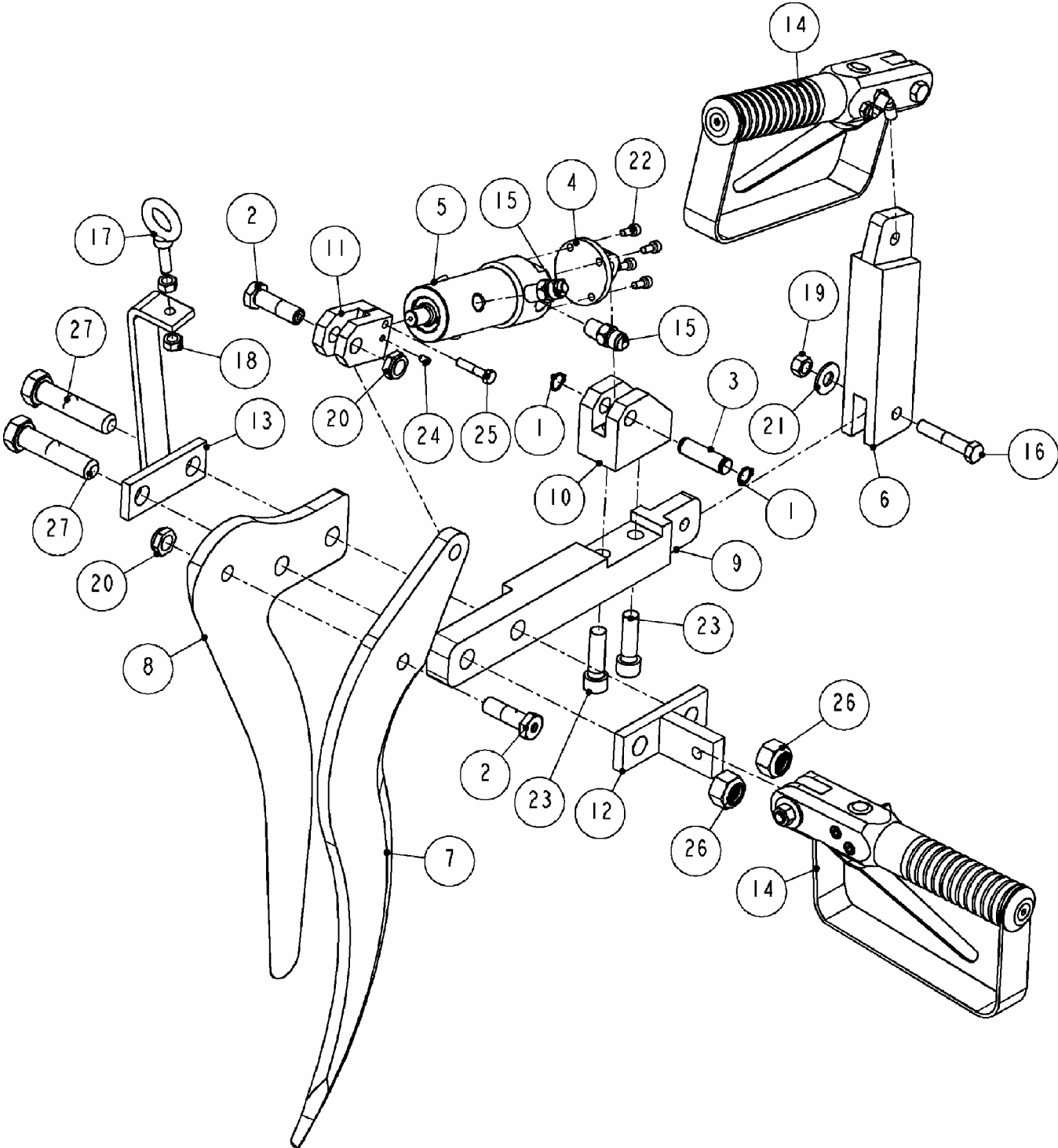
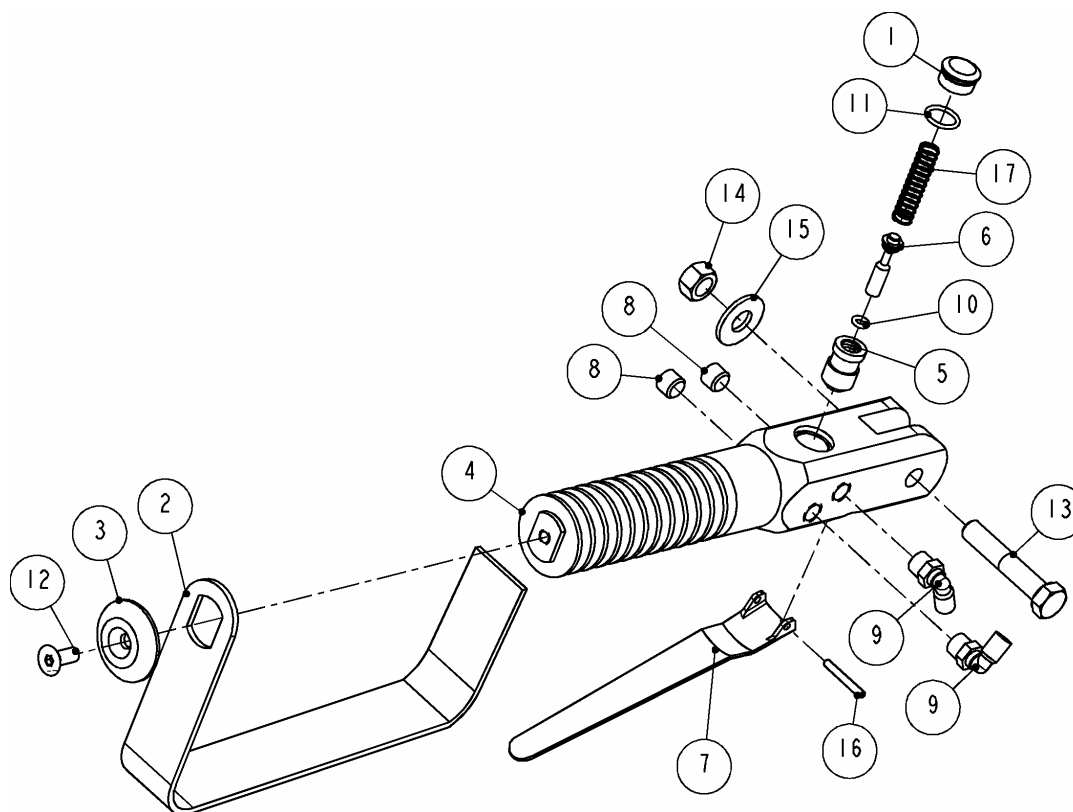

Figure 2 MODEL "SBS-2" – MAIN ASSEMBLY

6240500: SBS-2, SHEEP BRISKET SHEAR			
ITEM	PART #	DESCRIPTION	QTY
1	5100500	RETAINING RING	2
2	6240120	PIN	2
3	6240190	PIN	1
4	6240250	CLEVIS, REAR CYLINDER	1
5	6240300	CYLINDER ASSEMBLY	1
6	6240310	BRACKET, HANDLE	1
7	6240330	BLADE, MOVABLE	1
8	6240340	BLADE, FIXED	1
9	6240350	FRAME	1
10	6240360	BRACKET	1
11	6240380	CLEVIS, CYLINDER	1
12	6240390	BRACKET, HANDLE	1
13	6240400	HANGER, C'BALANCE	1
14	6600530	AIR HANDLE	2
15	7012130	CONNECTOR	2
16	8415160	SCREW	1
17	8463070	SHOULDER EYE BOLT	1
18	8500130	NUT	2
19	8500150	NUT	1
20	8504720	NUT	2
21	8505160	WASHER	1
22	9209040	SCREW	4
23	9219120	SCREW	2
24	9333010	SET SCREW	1
25	9411080	SCREW	1
26	9505190	NUT	2
27	9519220	SCREW	2

Figure 3 BOM FOR MODEL "SBS-2"

HANDLES

6600530: AIR HANDLE			
ITEM	PART #	DESCRIPTION	QTY
1	6300770	VALVE PLUG	1
2	6541690	GUARD	1
3	6541720	RETAINER	1
4	6600340	HANDLE	1
5	6600350	BUSHING	1
6	6600360	VALVE STEM	1
7	6600500	LEVER	1
8	7000010	PLUG	2
9	7036510	ELBOW	2
10	7680080	O-RING	1
11	7680140	O-RING	1
12	8241050	SCREW	1
13	8415160	SCREW	1
14	8500150	NUT	1
15	8505160	WASHER	1
16	8653140	PIN	1
17	8890010	SPRING	1

Figure 4 6600530: AIR HANDLE

SBS-2 TUBING DIAGRAM

WITHOUT ANTI-TIE DOWN OPTION

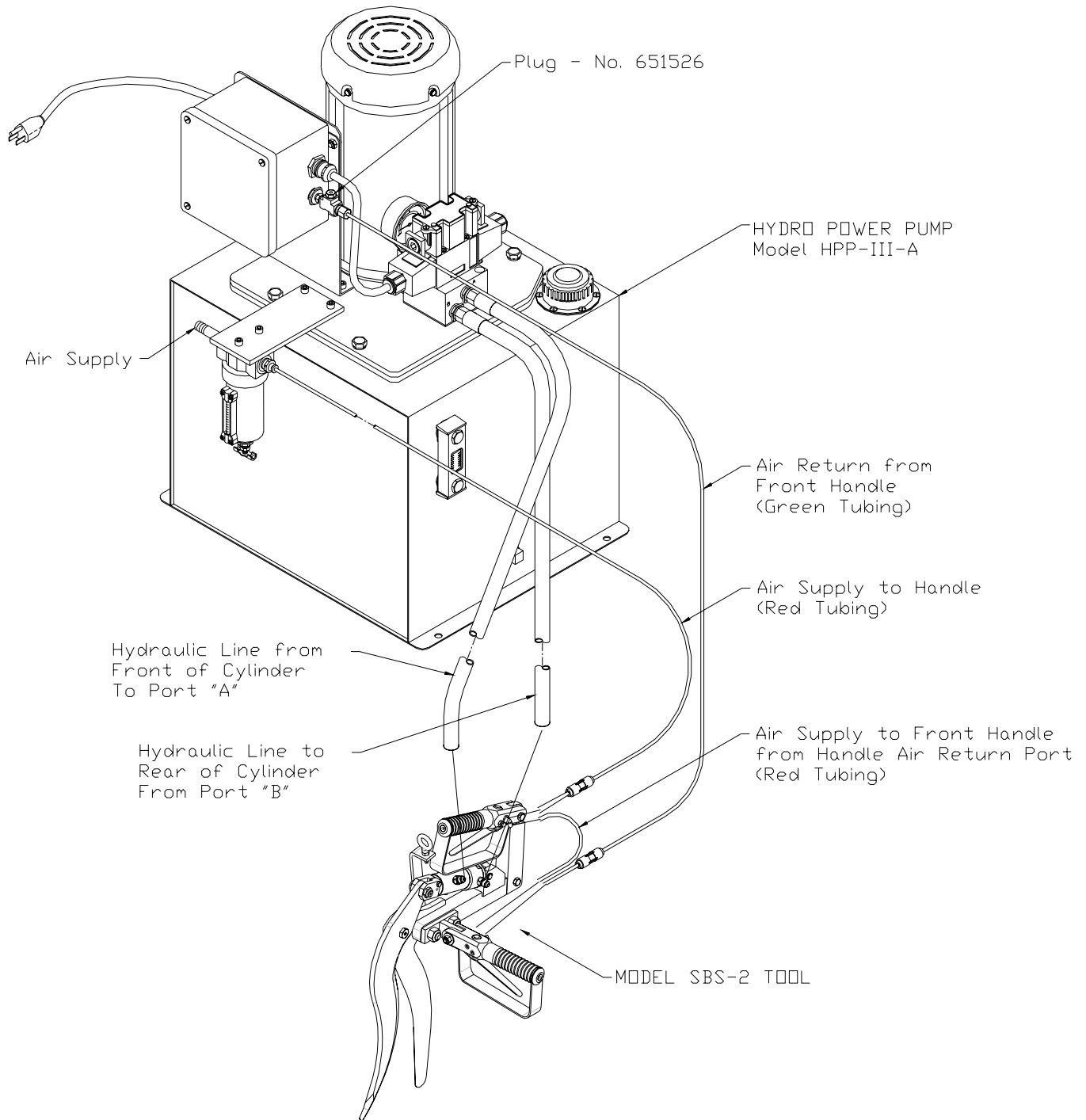

Figure 6 SBS-2 TUBING DIAGRAM – WITHOUT ANTI-TIE DOWN

WITH ANTI-TIE DOWN OPTION

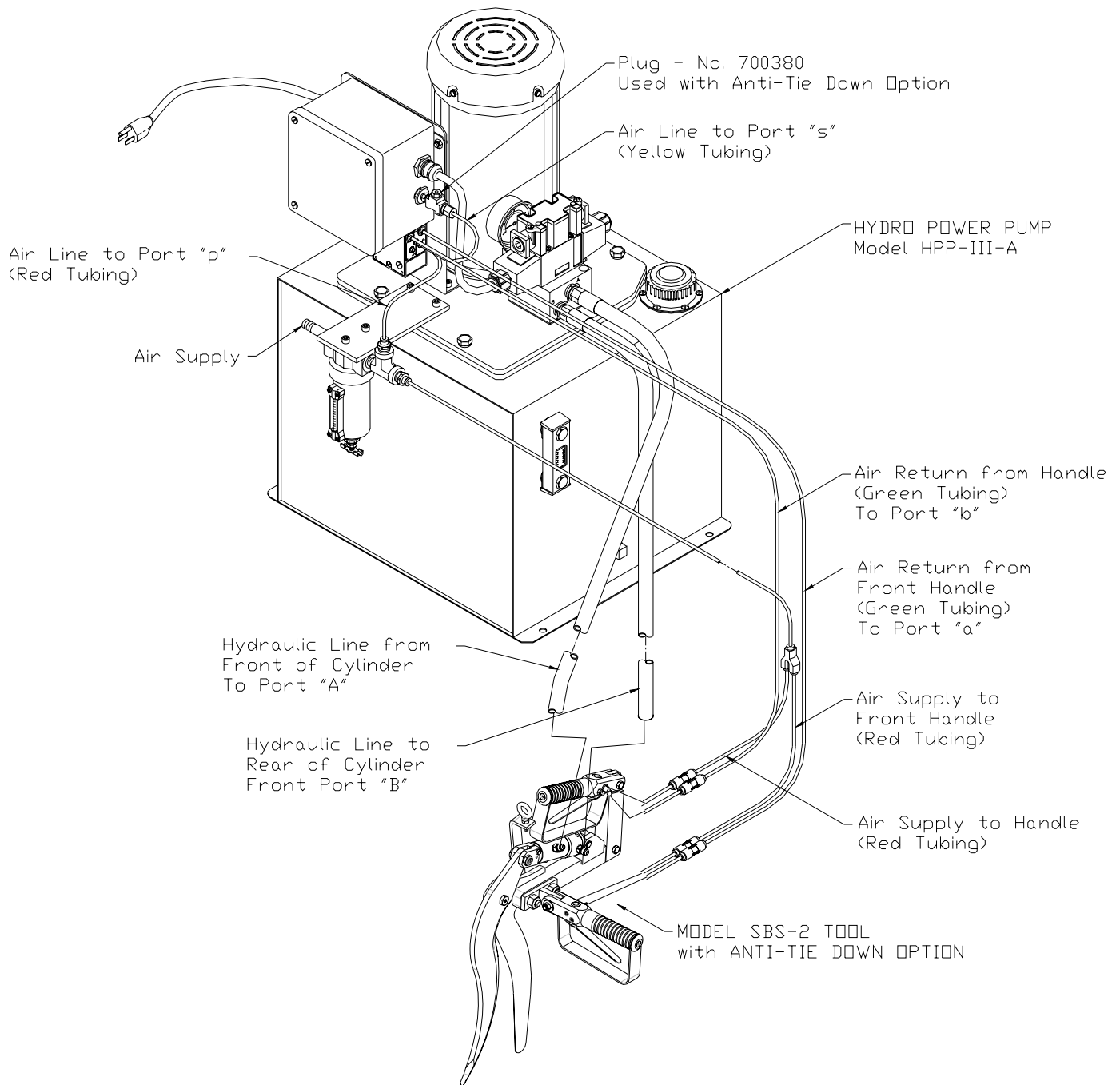
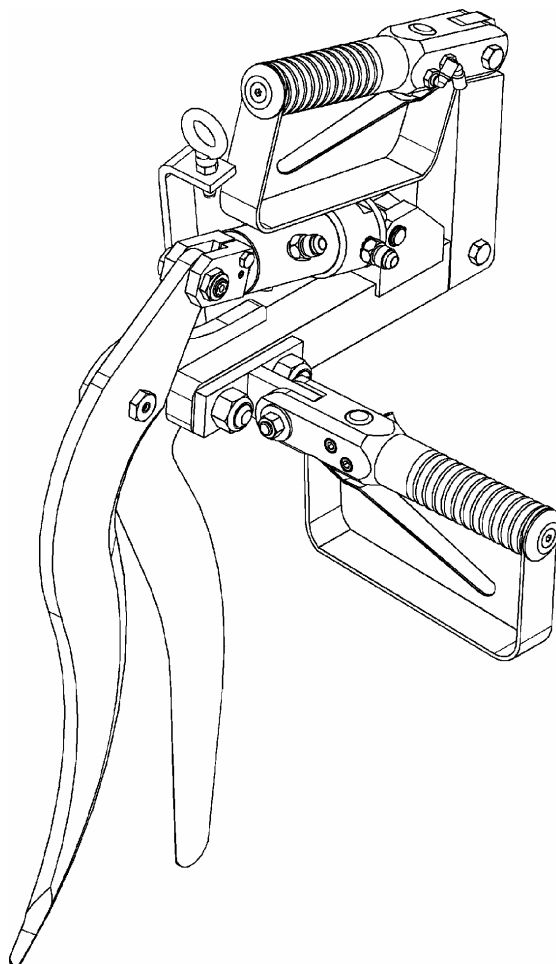

Figure 7 SBS-2 TUBING DIAGRAM – WITH ANTI-TIE DOWN

[ENGLISH]

GENERAL INFORMATION

MODELS
“SBS-2” SHEEP BRISKET SHEAR

SERVICE CENTERS

KENTMASTER LTD. (U.K)
 16 AVONBANK INDUSTRIAL CENTRE
 WEST TOWN ROAD
 AVONMOUTH - BRISTOL BS11 9DE
 UNITED KINGDOM

☎ TELEPHONE: ++ 44- (0) 117- 9235035
 FAX: ++ 44- (0) 117- 9829010

KENTMASTER MFG. CO., INC.
 1801 SOUTH MOUNTAIN AVE.
 MONROVIA, CALIFORNIA 91016
 UNITED STATES OF AMERICA

☎ TELEPHONE: (626) 359-8888
 FAX: (626) 303-5151

NOTICE TO EMPLOYER AND PURCHASER OF TOOL
NOTICE TO SAFETY DIRECTOR

You have purchased a powerful tool that, if misused, can cause severe injury and harm to your employees. You must instruct your employees in the safe and proper use of this tool and to follow the safety procedures and instructions that have been supplied by the manufacturer of this tool. Please follow the following instructions.

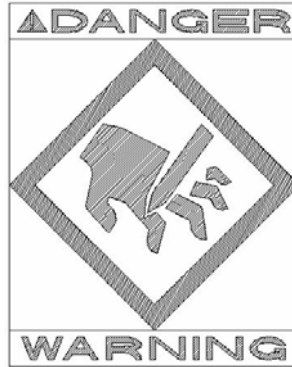

1. Instruct tool operators to test the tool each day before using it to be sure it does not malfunction. Remove and repair any tool that malfunctions.
2. Instruct tool operators to immediately stop using a tool that malfunctions or is defective.
3. Instruct personnel to immediately remove all tools that malfunction. Be sure to disconnect tool from power supply.
4. Instruct all personnel to stay clear of tool, and not to stand or walk in front of, or next to tool when in use.
5. Point out to all personnel the dangers related to the misuse of tool and the importance of following safety procedures and instructions.
6. Do not make, or allow others to make, alterations or modifications to this tool. Replace all lost or illegible labels.
7. Follow all safety, installation and maintenance instructions provided with this tool. Establish proper safety procedures in accordance with local and national requirements to prevent accidental energizing of tool that can cause injuries.
8. If this tool is sold or change in ownership takes place, you must provide the new owner all safety instructions, notices and maintenance instructions you were originally provided. You can obtain additional copies of the instructions from Kentmaster, free of charge upon request.
9. Give copies of instructions to:
 - (A) Tool Operators**
 - (B) Maintenance Supervisor**
 - (C) Clean-up Supervisor**

GENERAL INFORMATION

COVERING: SAFETY PRECAUTIONS AND PLACING INTO SERVICE
**HYDRAULICALLY OPERATED
SHEEP BRISKET SHEAR**

**READ THIS MANUAL CAREFULLY BEFORE INSTALLING, OPERATING OR SERVICING THIS
TOOL**

IT IS THE RESPONSIBILITY OF THE EMPLOYER TO PLACE THIS INFORMATION INTO THE HANDS OF THE OPERATOR.

PLACING INTO SERVICE

 **WARNING** = Hazards or unsafe practices which could result in severe personal injury, death or substantial property damage.

 **CAUTION** = Hazards or unsafe practices which could result in minor personal injury, product or property damage.

 **NOTICE** = Important installation, operation or maintenance information.

 **WARNING** Installation, adjustment repair and maintenance of this tool must be made by trained and qualified personnel.

 **WARNING** Always disconnect power supply from tool before:
(A) Installing or removing blade from tool.
(B) Making repairs or adjustments to the tool.
(C) performing maintenance or cleanup work.

DECLARATION OF CONFORMITY**DECLARATION OF CONFORMITY**DECLARATION DE CONFORMITE -DECLARACION DE CONFORMIDAD- ERKLARUNG BEZUGLICH EINHALTUNG DER VORSCHRIFTEN
DICHIARAZIONE DI CONFORMITA . CONFORMITEITSVERKLARING**MANUFACTURED BY:**FABRIQUE PAR:
FABRICADA POR:
HERGESTELLTVON:
FABBRICATO DA:
VERVAARDIGD DOOR:**KENTMASTER MFG CO., INC.**1801 SOUTH MOUNTAIN AVE.
MONROVIA, CALIFORNIA 91016
UNITED STATES OF AMERICA
TELEPHONE (626) 359-8888 FAX (626) 303-5151**TYPE / SERIES: SHEEP BRISKET SHEAR**TYPE / SERIE:
TIPO / SERIE:
TYP / SERIE:
TIPO / SERIE:
TYPE / SERIE:**MODEL: SBS-2**MODELE:
MODELO:
MODELL:
MODELLO:
MODEL:**SERIAL NO. RANGE: XXXXX**

N SERIE: • GAMA DE No. DE SERIE: • SERIEN-NR.-BEREICH: • NUMERI DI SERIE: • SERIENUMMERS:

This product complies with the following European Community Directives:Ce produit est conforme aux directives de la Communauté européenne suivantes:
Este producto cumple con las siguientes Directrices de la Comunidad Europea:
Dieses Produkt erfüllt die folgenden Vorschriften der Europäischen Gemeinschaft:
Questo prodotto è conforme alle seguenti direttive CEE:
Dit produkt voldoet aan de volgende EG-richtlijnen:**89/392/EEC, 91/368/EEC, 93/44/EEC, 93/68/EEC****The following Standards were used to verify compliance with the Directives:**Les normes suivantes ont été utilisées pour vérifier la conformité avec les Directives:
Las siguientes Normas se usaron para verificar el cumplimiento de las Directrices:
Folgende Normen wurden angewandt, um Erfüllung der Vorschriften zu bestätigen:
Per verificare la conformità del prodotto alle direttive sono stati usati i seguenti standard:
De volgende normen zijn gebruikt om naleving van de richtlijnen te bevestigen:**EN 292****Approved by:** _____RALPH KARUBIAN MONROVIA, CA. U.S.A
(Engineering Manager) (Directeur technique) (gerente de ingenieria) (verantwortlicher Konstruktionsleiter) (Responsabile tecnico) (ondersteunend technisch manager)**Date: JUN - 1 - 2006**

Kentmaster Worldwide Location

Kentmaster Equipment (Aust) PTY.LTD.

Unit 2,24 Central Court
Browns Plains Qld. 4118
Australia

Telephone: (07) 3806-8400

Fax: (07) 3806-7933

Australia@Kentmaster.com

Kentmaster do Brasil, Ltda.

Av. Dr. Joao Teodoro No. 805
Bairro De Vila Rezende
13405-240 Piracicaba, SP,
Brazil

Telephone #1: (019) 3 413 3113

Telephone #2: (019)983-4973

Fax: (019) 3 413 3113

Brazil@Kentmaster.com

Kentmaster (IRL) LTD.

Benamore, Dublin Road.
Roscrea,
CO, Tipperary,
Ireland

Telephone: (353) 0505-23292

Fax: (353) 0505-23299

Ireland@Kentmaster.com

Kentmaster Equipment (NZ) LTD.

5 Cooper Street
Havelock North
New Zealand

Telephone #1: (64) 6 8777 857

Telephone #2: 0800 KENTMASTER

Fax: (64) 6 8777 858

NewZealand@Kentmaster.com

Kentmaster South Africa (PTY) LTD.

Johannesburg - S. Africa
Unit 54 Sunnyrock Park
Sunrock Close, Germiston
South Africa

Telephone: (27) 11-455-3748

Fax: (27) 11-455-3749

SouthAfrica@Kentmaster.com

Kentmaster (UK) LTD.

Unit 16 Avonbank Ind. Centre
West Town Rd, Avonmouth-Bristol,
BS11 9DE
England

Telephone: (44) 117-923-5035

Fax: (44)-117-932-9010

UK@Kentmaster.com

Kentmaster Mfg. Co., Inc.

1801 South Mountain Ave.
Monrovia, CA, 91016
USA

Telephone #1: (626) 359-8888

Telephone #2: (800) 421-1477

Fax: (626) 303-5151

info@Kentmaster.com

Kentmaster Omaha

4417 South 139th Street
Omaha, NE, 68137
USA

Telephone #1: (402) 896-3355

Telephone #2: (800) 367-3181

Fax: (402) 896-3311

Omaha@Kentmaster.com

INDEX

OPERATING AND SAFETY INSTRUCTIONS..... 2

OPERATING INSTRUCTIONS..... 3

MAINTENANCE..... 3

SERVICE 4

PARTS BOOK..... 5

MAIN ASSEMBLY 5

HANDLES 7

CYLINDER ASSEMBLY 8

SBS-2 TUBING DIAGRAM 9

 WITHOUT ANTI-TIE DOWN OPTION..... 9

 WITH ANTI-TIE DOWN OPTION..... 10

GENERAL INFORMATION 13

DECLARATION OF CONFORMITY..... 14

Kentmaster Worldwide Location 15

INDEX..... 16

FIGURES - INDEX..... 16

FIGURES - INDEX

Figure 1 MODEL SBS-2 – BLADE REPLACEMENT..... 3

Figure 2 MODEL “SBS-2” – MAIN ASSEMBLY 5

Figure 3 BOM FOR MODEL “SBS-2” 6

Figure 5 6600530: AIR HANDLE 7

Figure 7 6240300: HYDRAULIC CYLINDER ASSEMBLY 8

Figure 8 SBS-2 TUBING DIAGRAM – WITHOUT ANTI-TIE DOWN 9

Figure 9 SBS-2 TUBING DIAGRAM – WITH ANTI-TIE DOWN 10