

OPERATOR'S MANUAL [ENGLISH]:

**RECIPROCATING QUARTERING
AND ALL-PURPOSE SAW**

INCLUDING: OPERATION, INSTRUCTION, INSTALLATION AND MAINTENANCE

IMPORTANT: READ THIS MANUAL CAREFULLY BEFORE INSTALLING, OPERATING OR
SERVICING THIS TOOL.

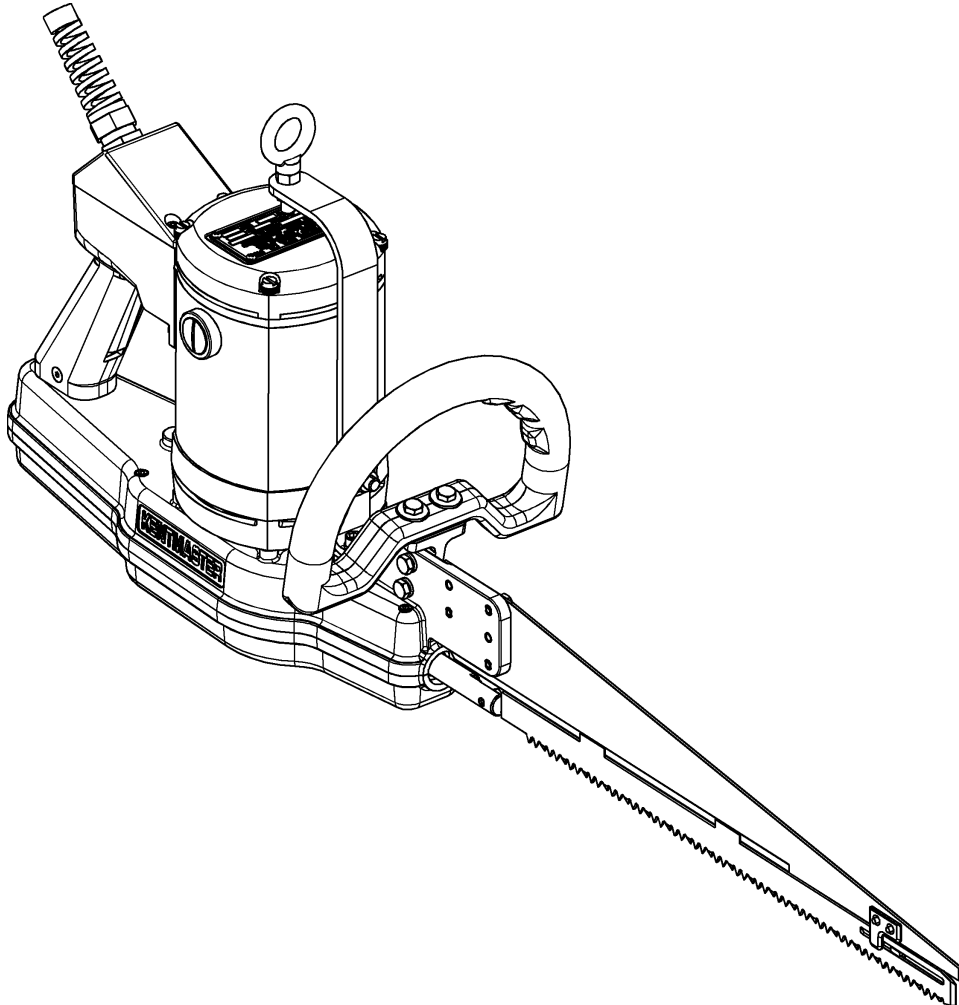

ZIP SAW

***Powerful Universal Splash-Proof Motor
8000 Cutting Stokes per Minute
Counterbalanced for Reduced Vibration
Easy to Clean and Sanitize***

KENTMASTER MFG. CO., INC. 1801 SOUTH MOUNTAIN AVE., MONROVIA, CALIFORNIA 91016 UNITED STATES OF AMERICA

☎ TELEPHONE: (626) 359-8888 FAX: (626) 303-5151

TOOL DATA

MODEL: ZIP SAW
 ASSEMBLY NO.: 1900000
 TYPE: ELECTRICALLY OPERATED
 NET WEIGHT: 18.2 lbs (8 kg)

MOTOR OUTPUT:

VOLTAGE: 115/230
FREQUENCY POWER SUPPLY: 50/60 single phase
BLADE LENGTH: 16" (406mm) / 8" (203mm)
PROTECTION CLASS: IP24

ACCESSORIES

ACCESSORIES	PART NO.
SPRING BALANCERS, 13-18 Lbs, 8.2 ft TRAVEL	7100220
SAW BLADE 16"	4100302
SAW BLADE 8"	4100400

Important!! Maintenance Procedure

Zipsaw is a powerful high speed reciprocating tool that operates with 8500 cutting strokes per minute. Due to high speed and power, operation and maintenance guidelines have to be followed.

1. Long continued tool usage could result in higher working temperature. **The operator has to wear protective gloves,**
2. Zipsaw has to be taken apart, checked for defective parts, greased and cleaned on a **monthly basis:**
 - Take it apart.
 - Clean
 - Check components for wear
 - Replace components as required
 - Grease – Use only Kentmaster-recommended grease; low-quality grease could cause premature wear and tear. **Use Kentmaster grease 7903100 (11oz per machine). This is a food grade grease specially formulated for high speed and motion application. Using any other grease could cause premature wear and damage to the parts.**
 - The pinion gear (1901422) has to be tightened periodically. Pinion gear (with R.H. Thread) and safety screw (L.H. thread) – see **Figure below**, is also overload protection. Overloading the saw would **loosen the pinion gear and cause a rattling noise**. Stop using the saw and tighten the gear and the safety screw. Do not overload machine.

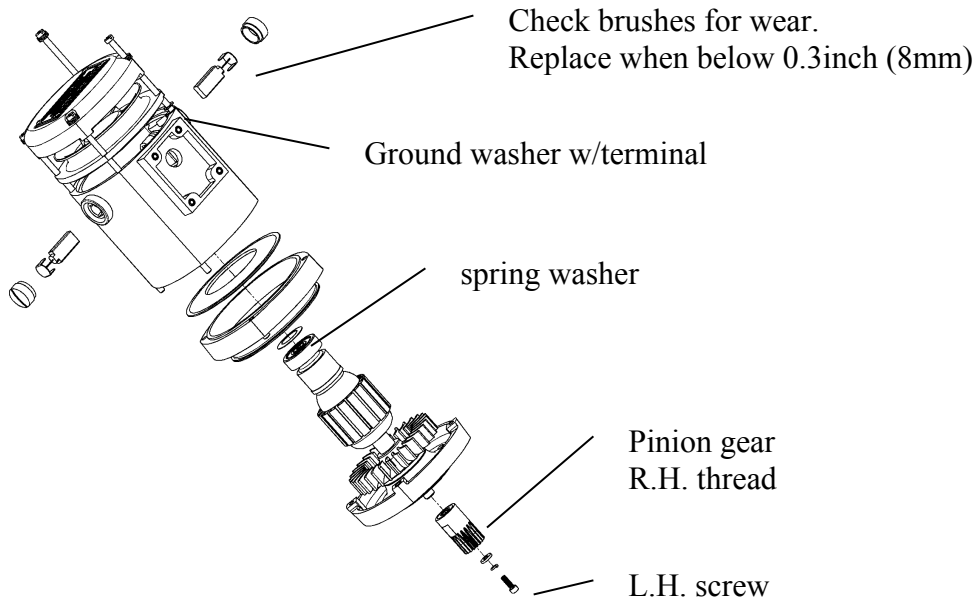

GENERAL INFORMATION

COVERING: SAFETY PRECAUTIONS AND PLACING INTO SERVICE
 SERIES 100 UNIVERSAL SAW

READ THIS MANUAL CAREFULLY BEFORE INSTALLING, OPERATING OR SERVICING THIS TOOL

IT IS THE RESPONSIBILITY OF THE EMPLOYER TO PLACE THIS INFORMATION INTO THE HANDS OF THE OPERATOR.

PLACING INTO SERVICE



= Hazards or unsafe practices which could result in severe personal injury, death, or substantial property damage.



= Hazards or unsafe practices which could result in minor personal injury, product, or property damage.



= Important installation, operation or maintenance information.



Installation, adjustment repair and maintenance of this tool must be made by trained and qualified personnel.



Always disconnect power supply from tool before:
 (A) Installing or removing blades from tool.
 (B) Making repairs or adjustments to the tool.
 (C) Performing maintenance or cleanup work.



Do not operate this tool until you have received training in the handling, operation and use of this tool.



If a malfunctioning or defective tool immediately, report any problems or defects to your supervisor for removal of the tool from service.



Never place your hand or any part of your body in the cutting path of the tool.

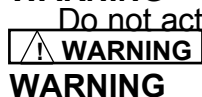

Do not activate control switches or triggers of this tool unless you intend to test or operate this tool.



Never make alterations or modifications to this tool.



Remove and disconnect power from the tool when tool is left unattended or not in use.

INSTALLATION INSTRUCTIONS

1. The tool operates on **50 or 60 Hz single phase AC current**.
2. Always check the **motor plate for voltage and amperage requirements**. This tool comes in either 115 Volt or 230 Volt configurations. The 115 Volt requires 110/120 Volt power supply, whereas the 230 Volt model requires 220/240 volt- power supply.

OPERATING INSTRUCTIONS

ONLY TRAINED PERSONNEL ARE TO OPERATE THIS TOOL.

WARNING

WARNING HOLD TOOL FIRMLY IN HAND WITH TRIGGER LEVER IN POSITION TO BE ACTIVATED BY FINGERS.

2. SQUEEZE TRIGGER TO ACTIVATED TOOL, RELEASE TRIGGER TO DEACTIVATE TOOL.
3. POSITION TOOL AND PERFORM CUTTING OPERATION.
4. DO NOT LAY TOOL DOWN WHEN TOOL IS NOT BEING USED.

MAINTENANCE

ONLY TRAINED AND QUALIFIED PERSONNEL ARE TO PERFORM MAINTENANCE AND SERVICE TO THIS TOOL.

WARNING

WARNING

1. TOOL REQUIRES GREASING. CHECK GREASE AFTER 100 OF OPERATION. USE KENTMASTER GREASE GUN NO. 4501470, FILL WITH GREASE KM#7903100. THE MACHINE IS ASSEMBLED AT FACTORY WITH 12 OZ. OF KM#7903100 .

BLADE REMOVAL AND CLEANING.

ALWAYS DISCONNECT POWER SUPPLY FROM TOOL BEFORE INSTALLING OR REMOVING BLADES FROM TOOL.

WARNING

1. LOSSEN SCREW IN BLADE SHAFT.
2. REMOVE BLADE FROM BLADE SHAFT.
3. INSERT NEW BLADE.
4. TIGHTEN SCREW INTO ALIGNMENT HOLE IN BLADE TO LOCK IN PLACE AGAINST SHAFT.

SERVICE

1. KEEP GOOD RECORDS OF ALL SERVICE ACTIVITY AND INCLUDE TOOL IN YOUR PREVENTIVE MAINTENANCE PROGRAM.
2. USE ONLY GENUINE KENTMASTER REPLACEMENT PARTS TO ASSURE PROPER PERFORMANCE OF TOOL.
3. CONTACT THE KENTMASTER SUPPLIER NEAREST YOU FOR PARTS AND CUSTOMER SERVICE INFORMATION.

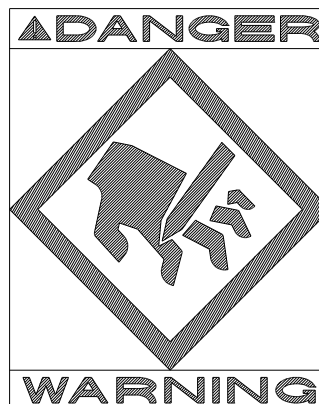

ZIP SAW
ZIP SAW ASSEMBLY

REV I: 05/02/07

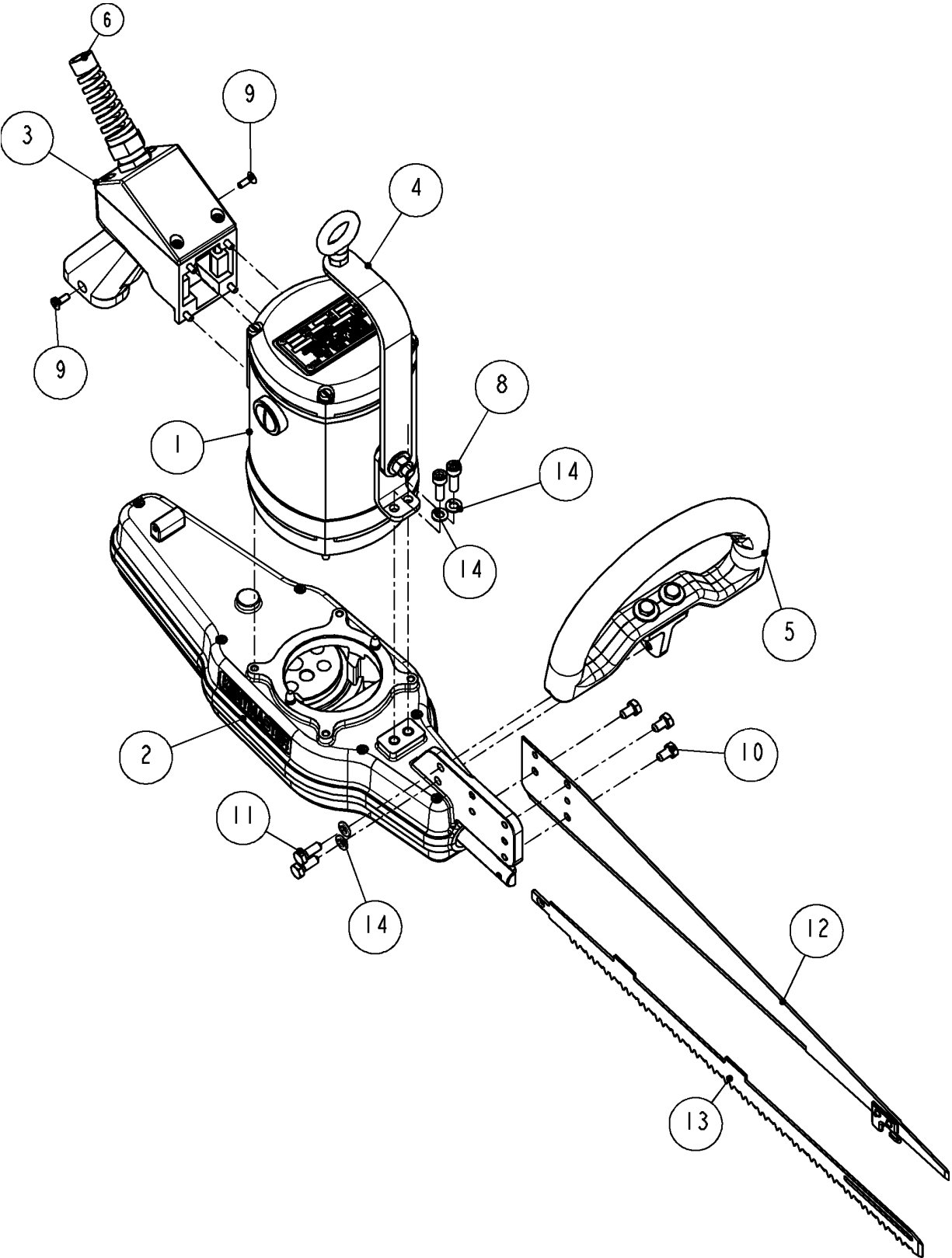

Figure 1 190000: ZIP SAW ASSEMBLY

1900000: ZIP SAW			
ITEM	PART #	DESCRIPTION	QTY
1	1900500-115-160	MOTOR ASSEMBLY 115V, 50/60 Hz	1
	1900500-230-160	MOTOR ASSEMBLY 230V, 50/60 Hz	1
2	1900100	CASE ASSEMBLY	1
3	1900800	REAR HANDLE	1
4	1902400	ASSEMBLY - HANGER	1
5	1902500	ASSEMBLY - FRONT HANDLE	1
6	2007080	POWER CORD, 115V	1
	2007090	POWER CORD, 230V	1
	2007140	POWER CORD, 230V- EUROPEAN	1
7	7903100	GREASE	1
8	9211060	SCREW	2
9	9238040	SCREW	2
10	9411020	SCREW	3
11	9411050	SCREW	2
12	1902200	ASSEMBLY 16" BLADE SUPPORT	1
	1902710	ASSEMBLY 8" BLADE SUPPORT	1
13	4100302	16" SAW BLADE	1
	4100400	8" SAW BLADE	1
14	9506100	WASHER	4

7100220	RANGE: 13lb TO 18lb, TRAVEL: 8.2 ft
PART #	DESCRIPTION
SPRING BALANCER (OPTIONAL)	

Figure 2 1900000: BOM, ZIP SAW ASSEMBLY

**ZIP SAW
MOTOR ASSEMBLY**

REV I: 05/02/07

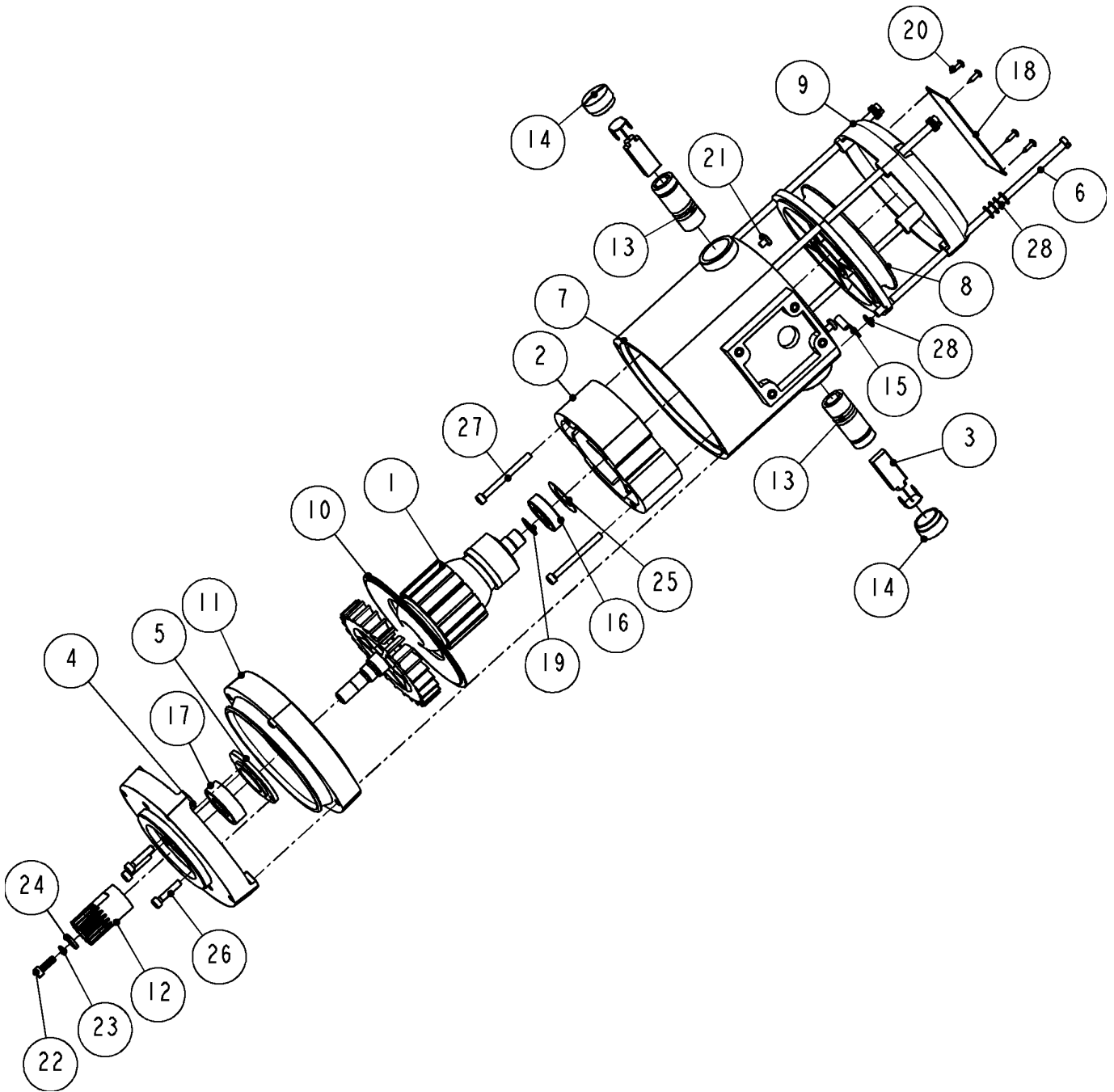

Figure 3 1900500-: MOTOR ASSEMBLY

1900500: MOTOR ASSEMBLY			
ITEM	PART #	DESCRIPTION	QTY
1	2316090	ROTOR, 115V, W/ FAN	1
	2316100	ROTOR, 230V, W/ FAN	1
2	2330060	STATOR, 115V	1
	2330070	STATOR, 230V	1
3	2308150	BRUSH W/ SPRING 115 VOLT	2
	2308090	BRUSH W/ SPRING 230 VOLT	2
4	1900256	BASE- MOTOR	1
5	1900257	RETAINER, MOTOR BEARING	1
6	1900550	SCREW, MOTOR HOUSING	4
7	1900710	HOUSING - MOTOR	1
8	1900740	MOTOR HOUSING TOP	1
9	1900750	TOP COVER, MOTOR	1
10	1900770	BAFFLE- MOTOR	1
11	1900780	FAN HOUSING	1
12	1901422	PINION	1
13	2308070	BRUSH HOLDER	2
14	2308080	CAP- BRUSH	2
15	2502045	TERMINAL, RING	1
16	3124010	BEARING	1
17	3204010	BEARING, BALL	1
18	4505120	NAME PLATE	1
19	5100460	RETAINING RING	1
20	8081020	SCREW	4
21	8088010	SCREW	2
22	8208370	SCREW	1
23	8506580	WASHER	1
24	8509170	WASHER	1
25	8712010	SPRING WASHER	1
26	9208060	SCREW	3
27	9208140	SCREW	2
28	9505130	WASHER	17

Figure 4 1900500: BOM, MOTOR ASSEMBLY

**ZIP SAW
CASE ASSEMBLY**

REV I: 05/02/07

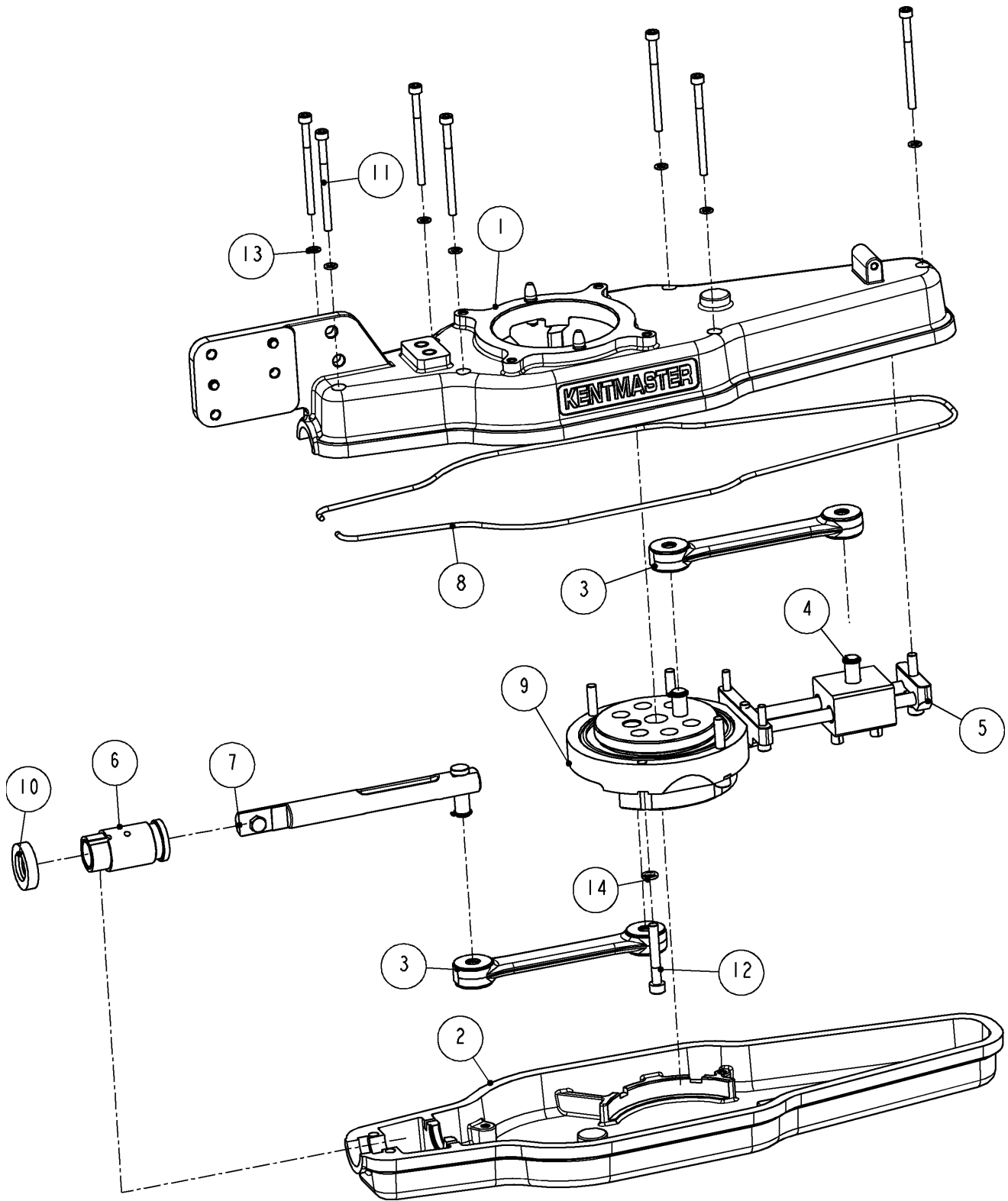
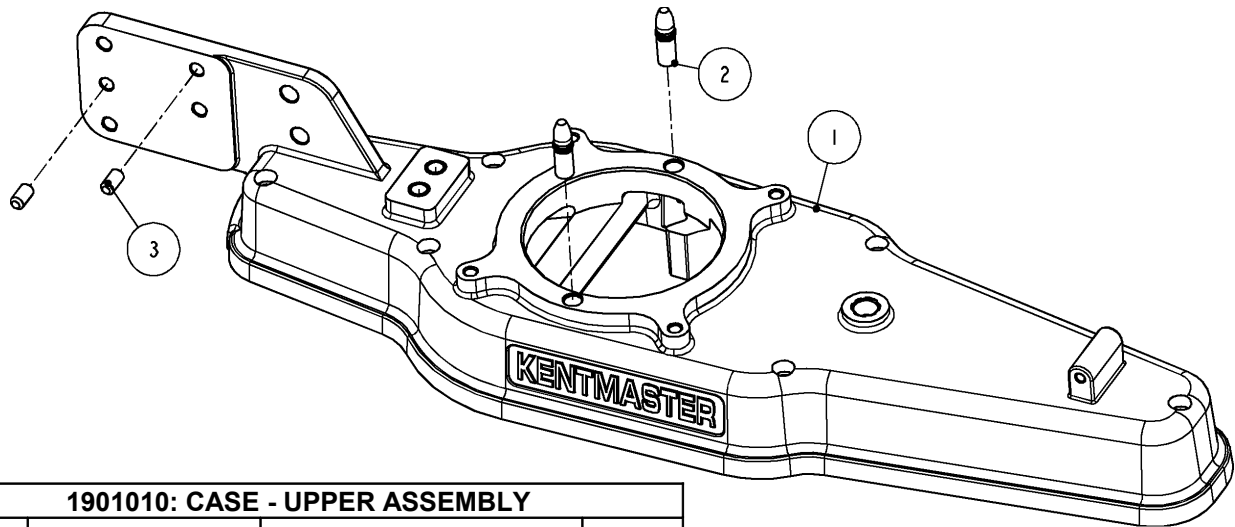

Figure 5 1900100: CASE ASSEMBLY

1900100: CASE ASSEMBLY			
ITEM	PART #	DESCRIPTION	QTY
1	1901010	CASE - UPPER ASSEMBLY	1
2	1901020	CASE - LOWER	1
3	1901100	CON ROD	2
4	1901250	COUNTER BALANCE ASSEMBLY	1
5	1901430	GUIDE ASSEMBLY	1
6	1901500	CARTRIDGE, BEARING ASSEMBLY	1
7	1901660	SAW SHAFT ASSEMBLY	1
8	1901730	O-RING SEAL	1
9	1902800	ASSEMBLY GEAR AND BEARING RING	1
10	7798310	SEAL	1
11	9208180	SCREW	7
12	9209110	SCREW	4
13	9506080	WASHER	7
14	9506090	WASHER	4

Figure 6 1900100: BOM, CASE ASSEMBLY



1901010: CASE - UPPER ASSEMBLY			
ITEM	PART #	DESCRIPTION	QTY
1	1901010-M	CASE - UPPER	1
2	8622500	DOWEL PIN	2
3	9620110	PIN	2

Figure 7 1901010: UPPER CASE

ZIP SAW

REV I: 05/02/07

1901100: CON ROD ASSEMBLY			
ITEM	PART #	DESCRIPTION	QTY
1	1901110	CONNECTING ROD	1
2	3705610	NEEDLE BEARING	2
3	3705630	THRUST WASHER	4

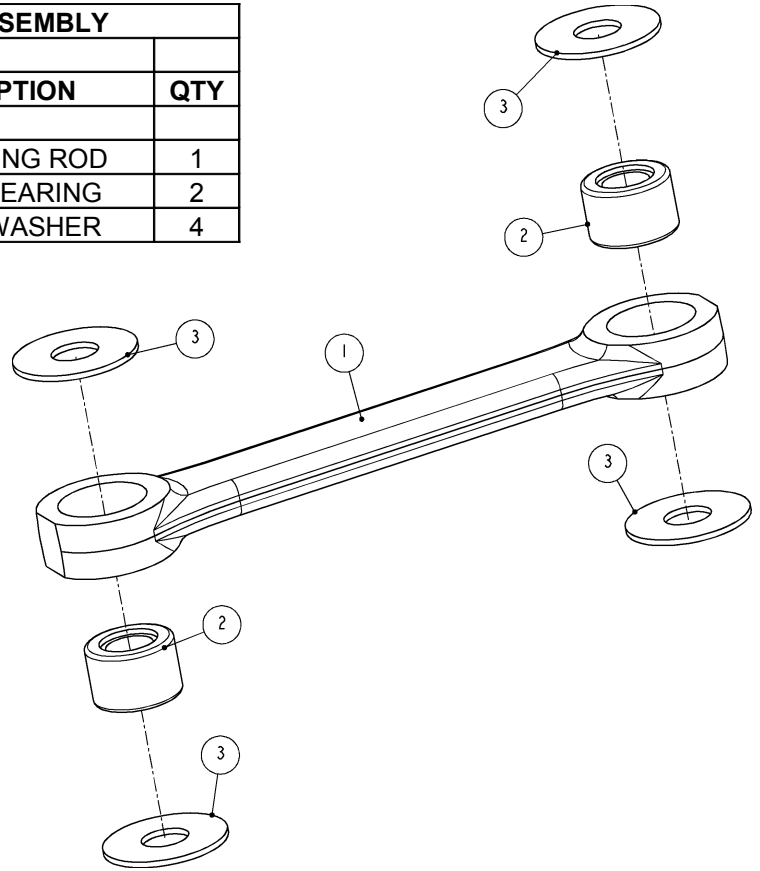

Figure 8 1901100: CON ROD

1901250: COUNTER BALANCE ASSEMBLY			
ITEM	PART #	DESCRIPTION	QTY
1	1901090	PIN-BEARING, CONROD	1
2	1901260	COUNTER BALANCE	1
3	3850700	BEARING	4
4	8614120	PIN	2
5	9700010	RETAINING RING	1

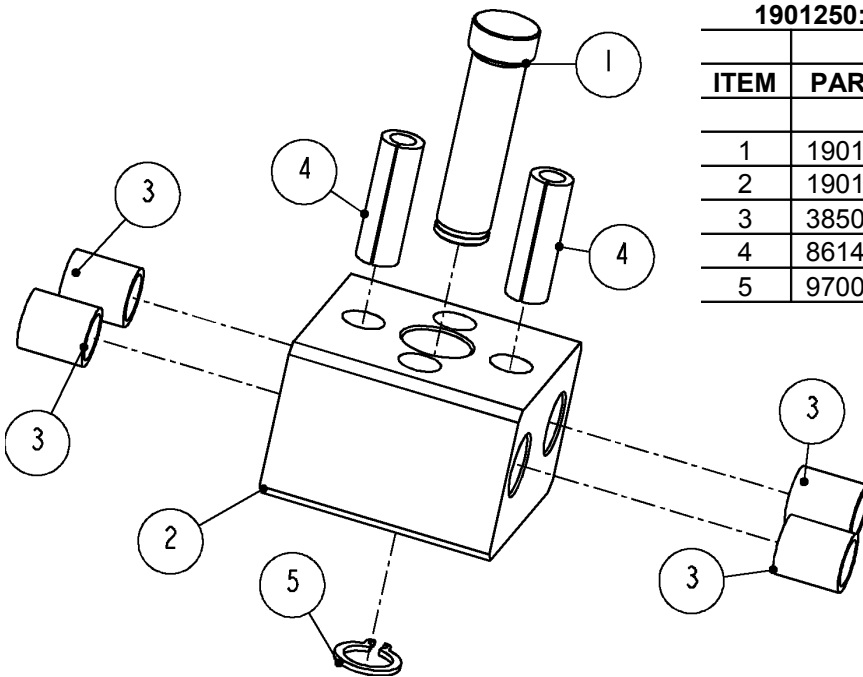
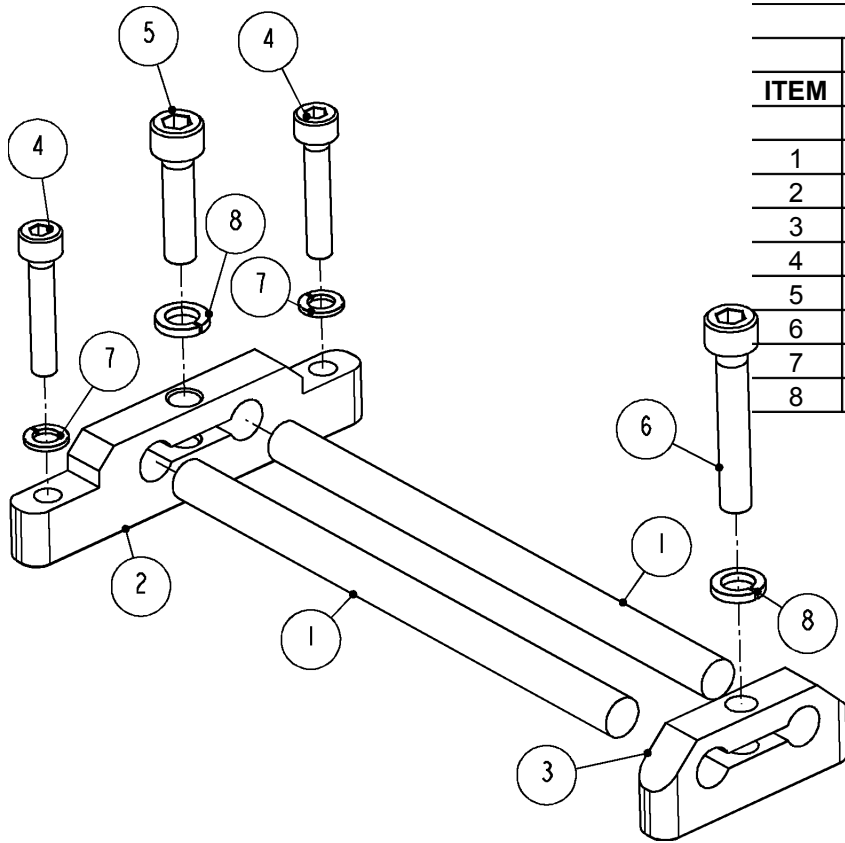
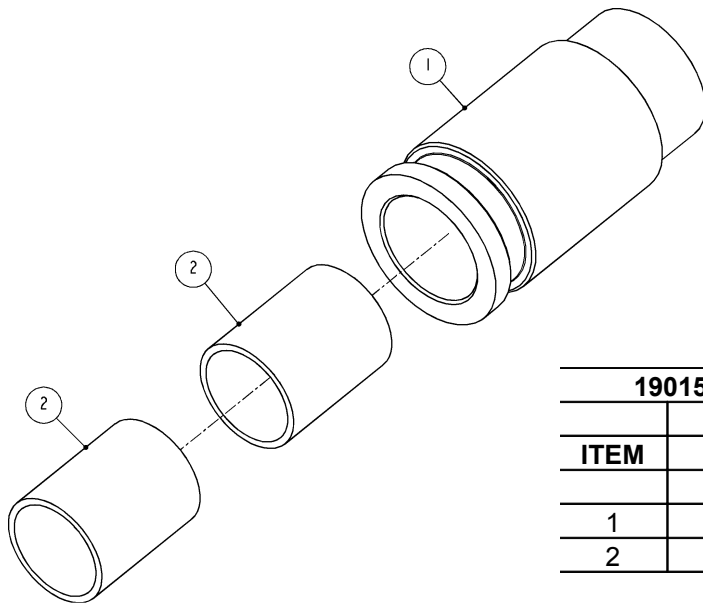

Figure 9 1901250: COUNTER BALANCE ASS'Y



1901430: GUIDE ASSEMBLY			
ITEM	PART #	DESCRIPTION	QTY
1	1901440	GUIDE	2
2	1901450	GUIDE BLOCK-LARGE	1
3	1901460	GUIDE BLOCK- SMALL	1
4	9208070	SCREW	2
5	9209060	SCREW	1
6	9209100	SCREW	1
7	9506080	WASHER	2
8	9506090	WASHER	2

Figure 10 1901430: GUIDE ASSEMBLY



1901500: CARTRIDGE, BEARING ASSEMBLY			
ITEM	PART #	DESCRIPTION	QTY
1	1901510	BEARING CARTRIDGE	1
2	3851330	BEARING	2

Figure 11 1901500: CARTRIDGE - BEARING ASSEMBLY

1901660: SAW SHAFT ASSEMBLY			
ITEM	PART #	DESCRIPTION	QTY
1	1901190	PIN-BEARING, CONROD	1
2	1901650	SHAFT	1
3	9409010	SCREW	1
4	9700010	RETAINING RING	1

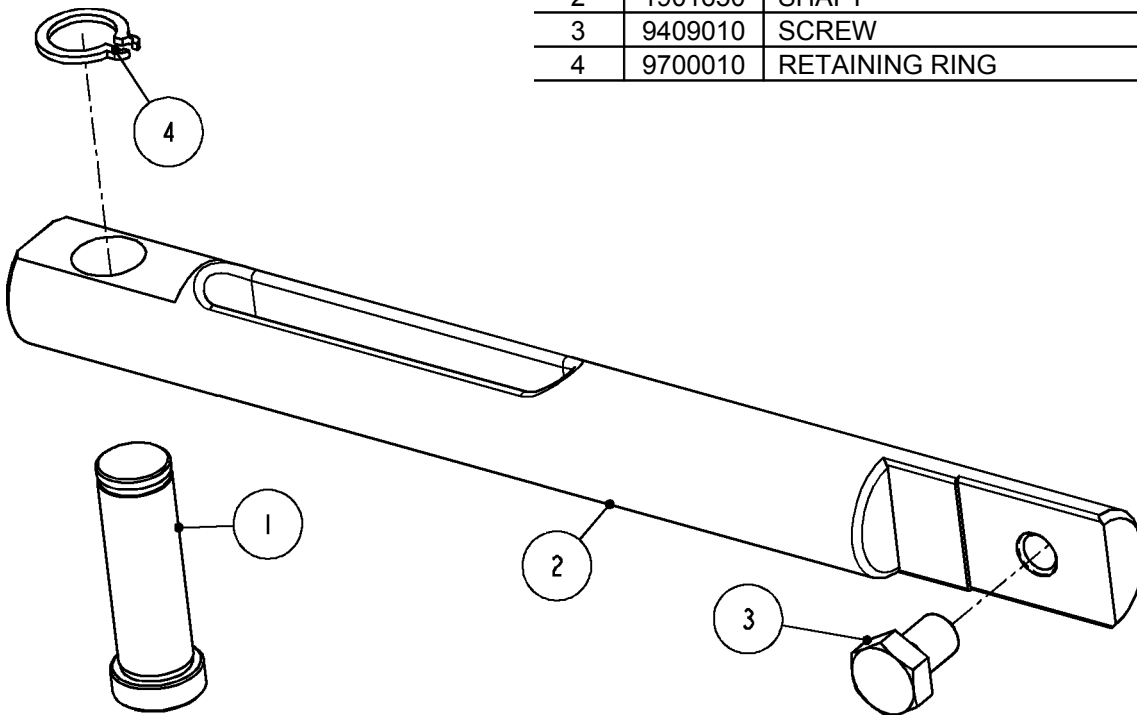
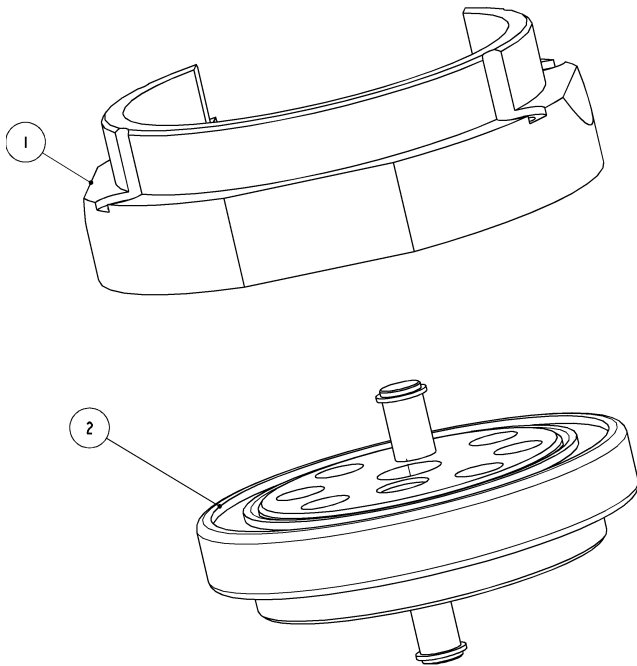

Figure 12 1901600: BLADE SHAFT ASSEMBLY



1902800: GEAR AND BEARING ASS'Y			
ITEM	PART #	DESCRIPTION	QTY
1	1901140	BEARING RING	1
2	1901400	GEAR ASSEMBLY	1

Figure 13 1902800: GEAR AND BEARING RING ASSEMBLY

1901400: GEAR ASS'Y			
ITEM	PART #	DESCRIPTION	QTY
1	1901090	PIN-BEARING, CONROD	2
2	1901410	GEAR	1
3	3102120	BEARING	1
4	9700010	RETAINING RING	2

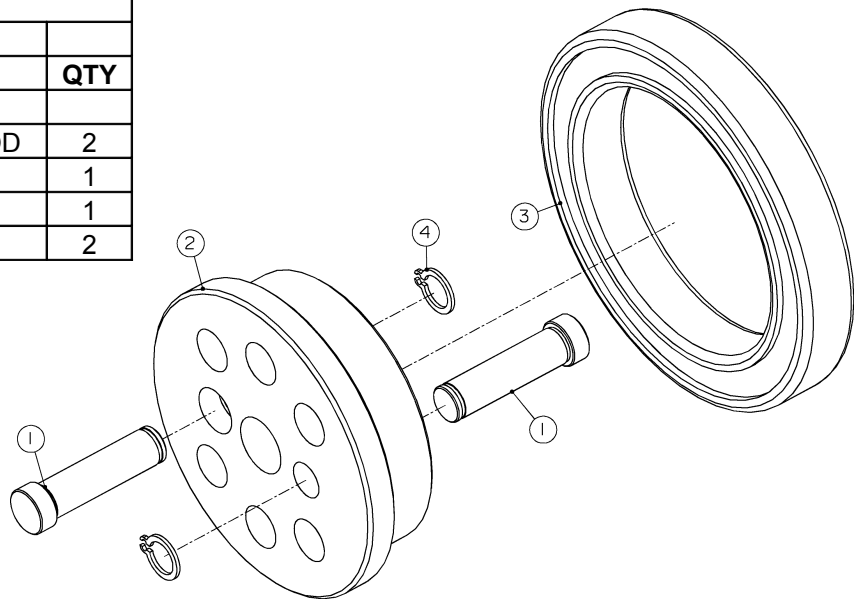
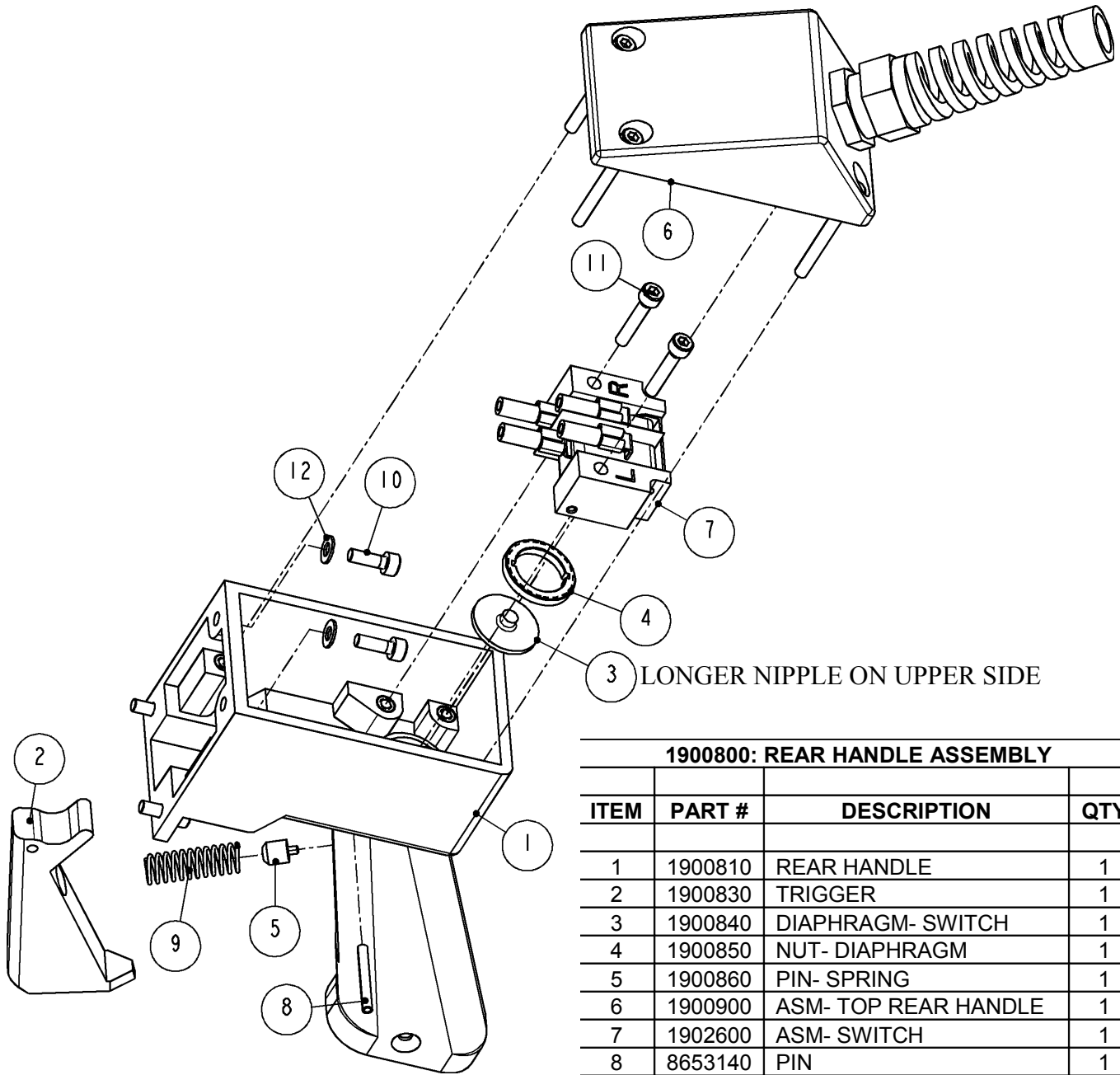

Figure 14 1901400: GEAR ASSEMBLY

REAR HANDLE ASSEMBLY



1900800: REAR HANDLE ASSEMBLY			
ITEM	PART #	DESCRIPTION	QTY
1	1900810	REAR HANDLE	1
2	1900830	TRIGGER	1
3	1900840	DIAPHRAGM- SWITCH	1
4	1900850	NUT- DIAPHRAGM	1
5	1900860	PIN- SPRING	1
6	1900900	ASM- TOP REAR HANDLE	1
7	1902600	ASM- SWITCH	1
8	8653140	PIN	1
9	8890050	SPRING	1
10	9208040	SCREW	4
11	9208070	SCREW	2
12	9510080	WASHER	4

Figure 15 1900800: REAR HANDLE ASSEMBLY

1900900: TOP - REAR HANDLE			
ITEM	PART #	DESCRIPTION	QTY
1	1900820	TOP REAR HANDLE	1
2	1900920	SEAL	1
3	2008540	CORD GRIP	1
4	9204120	SCREW	4
5	9510080	WASHER	4

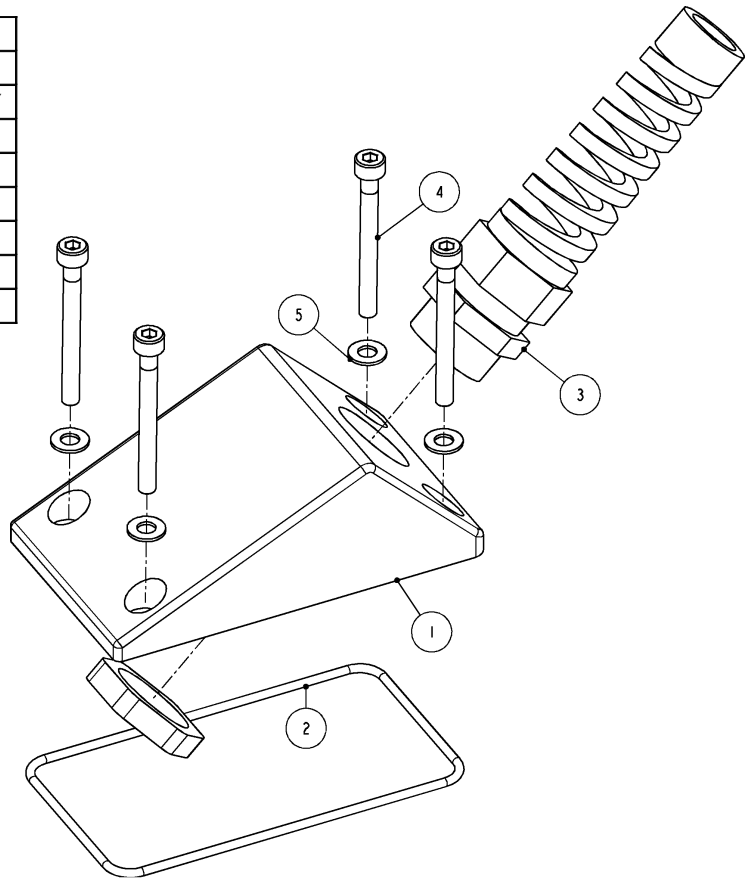
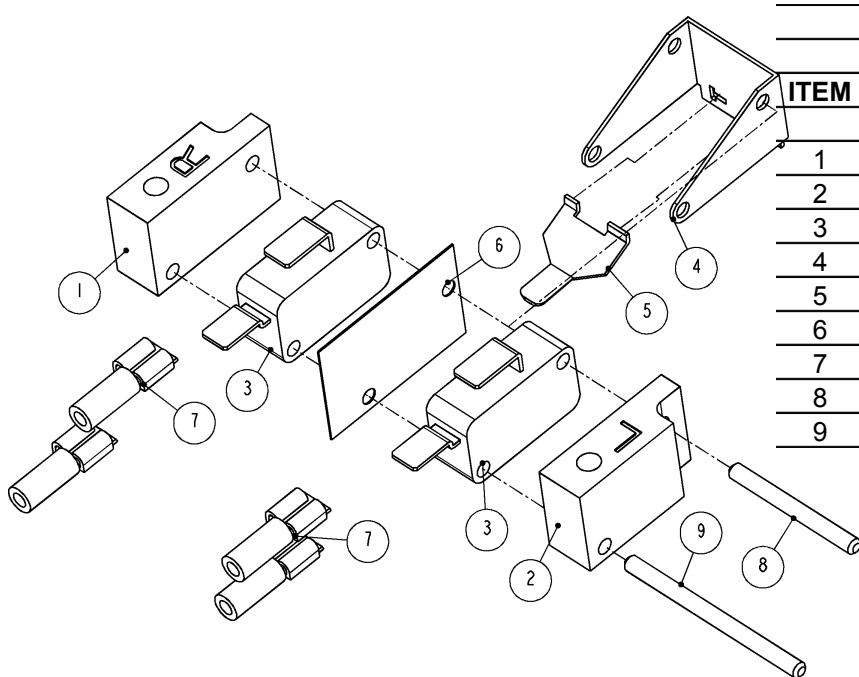

Figure 16 1900900: TOP - REAR HANDLE



1902600: SWITCH ASSEMBLY			
ITEM	PART #	DESCRIPTION	QTY
1	1902610	MOUNTING BLOCK, R	1
2	1902620	MOUNTING BLOCK, L	1
3	2000790	SWITCH	2
4	2000800	BRACKET- SWITCH	1
5	2000810	LEVER- SWITCH	1
6	2000820	INSULATION- SWITCH	1
7	2504105	DISCONNECT	4
8	8620090	PIN	1
9	8620110	PIN	1

Figure 17 1902600: SWITCH ASSEMBLY

FRONT HANDLE ASSEMBLY

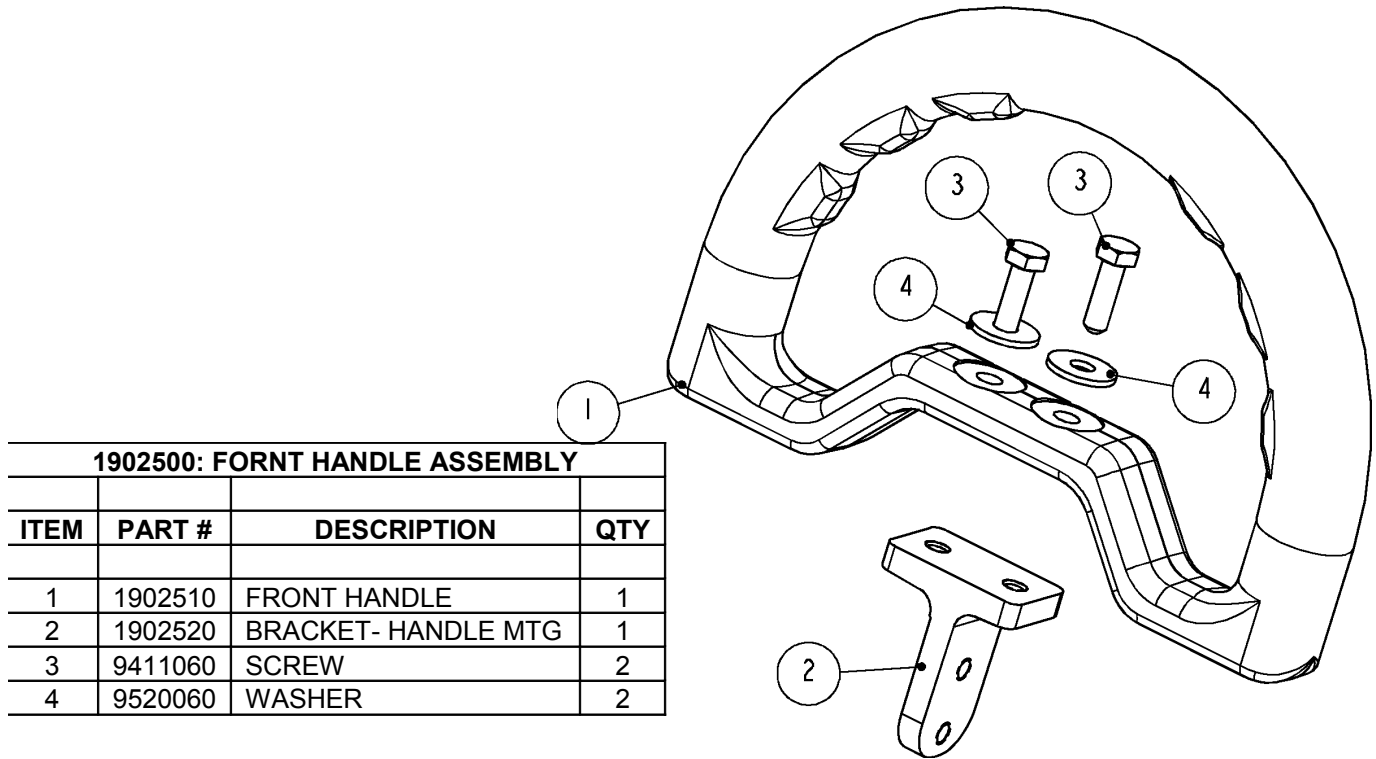

1902500: FORNT HANDLE ASSEMBLY			
ITEM	PART #	DESCRIPTION	QTY
1	1902510	FRONT HANDLE	1
2	1902520	BRACKET- HANDLE MTG	1
3	9411060	SCREW	2
4	9520060	WASHER	2

Figure 18 1902500: FRONT HANDLE ASSEMBLY

HANGER ASSEMBLY

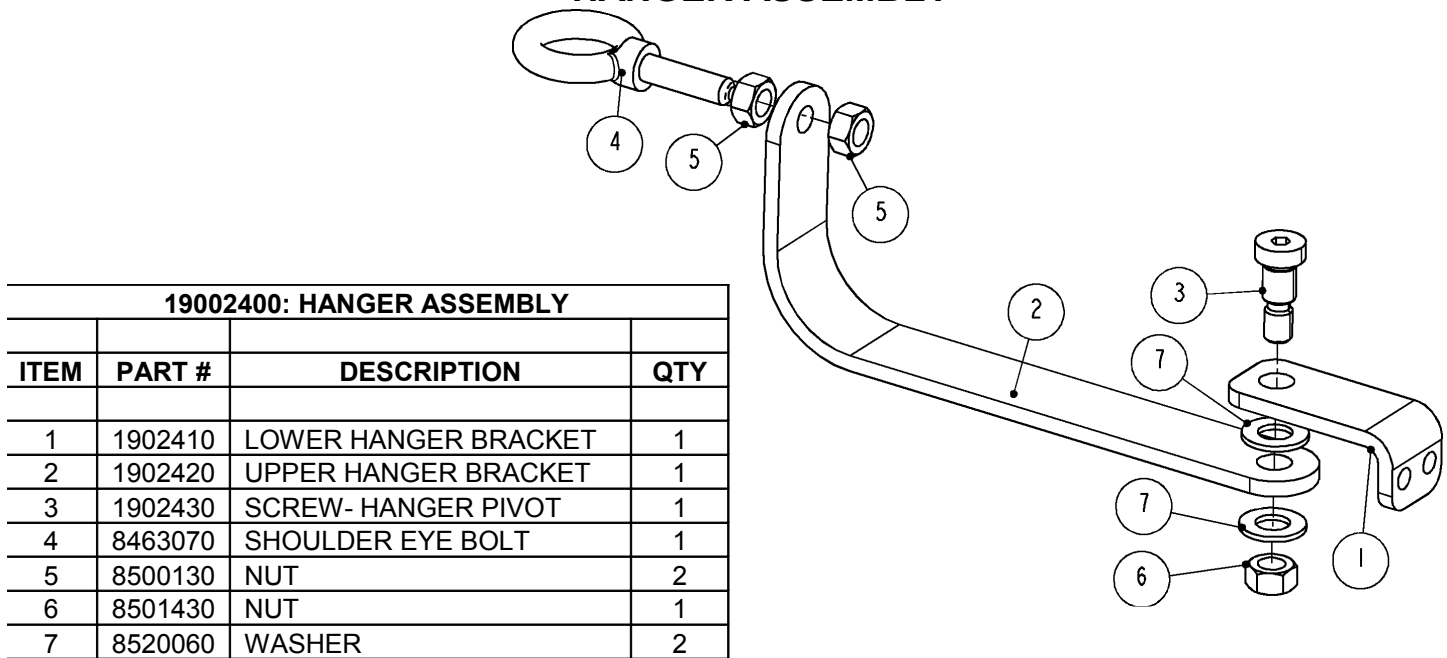

19002400: HANGER ASSEMBLY			
ITEM	PART #	DESCRIPTION	QTY
1	1902410	LOWER HANGER BRACKET	1
2	1902420	UPPER HANGER BRACKET	1
3	1902430	SCREW- HANGER PIVOT	1
4	8463070	SHOULDER EYE BOLT	1
5	8500130	NUT	2
6	8501430	NUT	1
7	8520060	WASHER	2

Figure 19 1902400: HANGER ASSEMBLY

BLADE AND BLADE SUPPORT OPTIONS

1902200: 16" BLADE SUPPORT			
ITEM	PART #	DESCRIPTION	QTY
1	1902210	BLADE GUIDE	2
2	1902252	BLADE SUPPORT, 16"	1
3	8451120	RIVET	2

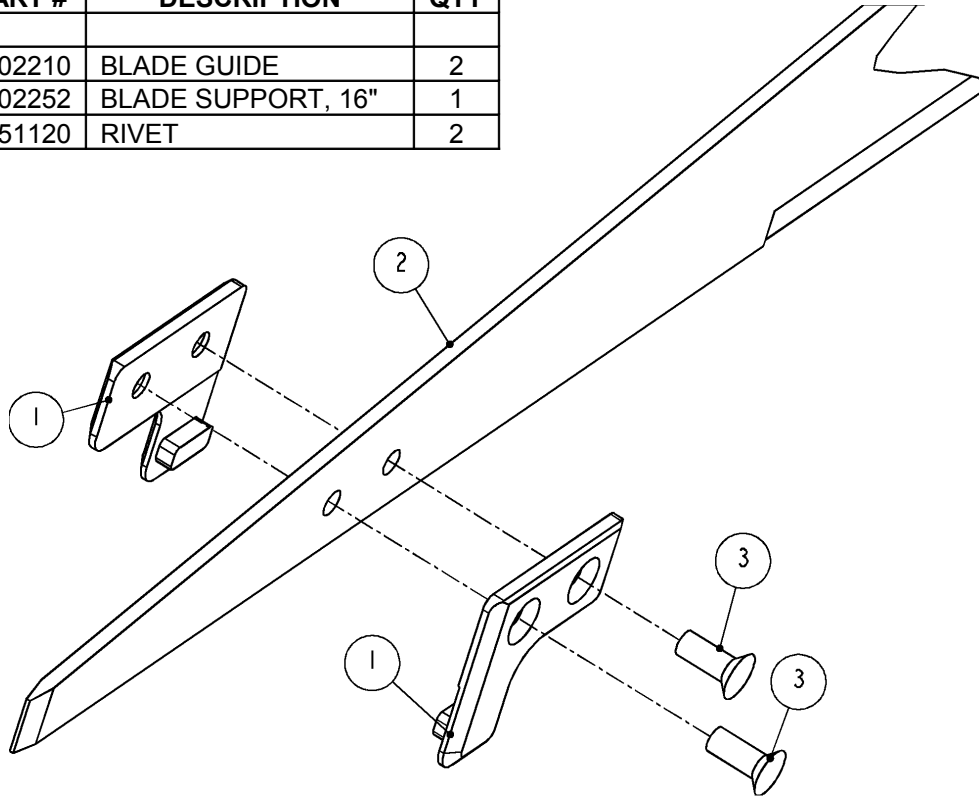

1902710: 8" BLADE SUPPORT			
ITEM	PART #	DESCRIPTION	QTY
1	1902210	BLADE GUIDE	2
2	1902260	BLADE SUPPORT, 16"	1
3	8451120	RIVET	2

Figure 20 BLADE SUPPORT

SPARE PARTS LIST

RECOMMENDED SPARE PARTS SHORT-TERM MAINTENANCE

PART NO.	DESCRIPTION	QTY
4100400 or 4100302	8" Blade OR 16" Blade	4
7798310	Seal - Front	1
1901500	Assembly Bearing Cartridge	1
1901730	Seal - Case	1
2308090 or 2308150	Brush - Motor	8
1900840	Diaphragm - Switch	2

NOTICE TO EMPLOYER AND PURCHASER OF TOOL NOTICE TO SAFETY DIRECTOR

You have purchased a powerful tool that, if misused, can cause severe injury and harm to your employees. You must instruct your employees in the safe and proper use of this tool and to follow the safety procedures and instructions that have been supplied by the manufacturer of this tool. Please follow the following instructions.

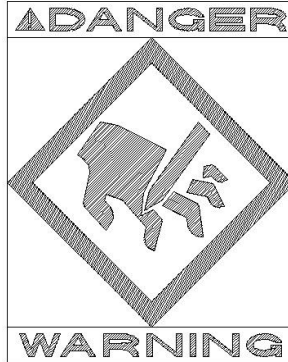

1. Instruct tool operators to test the tool each day before using it to be sure it does not malfunction. Remove and repair any tool that malfunctions.
2. Instruct tool operators to immediately stop using a tool that malfunctions or is defective.
3. Instruct personnel to immediately remove all tools that malfunction. Be sure to disconnect tool from power supply.
4. Instruct all personnel to stay clear of tool, and not to stand or walk in front of, or next to tool when in use.
5. Point out to all personnel the dangers related to the misuse of tool and the importance of following safety procedures and instructions.
6. Do not make, or allow others to make, alterations or modifications to this tool. Replace all lost or illegible labels.
7. Follow all safety, installation and maintenance instructions provided with this tool. Establish proper safety procedures in accordance with local and national requirements to prevent accidental energizing of tool that can cause injuries.
8. If this tool is sold or change in ownership takes place, you must provide the new owner all safety instructions, notices and maintenance instructions you were originally provided. You can obtain additional copies of the instructions from Kentmaster, free of charge upon request.
9. Give copies of instructions to:
 - (A) Tool Operators**
 - (B) Maintenance Supervisor**
 - (C) Clean-up Supervisor**

KENTMASTER MFG. CO., INC. 1801 SOUTH MOUNTAIN AVE., MONROVIA, CALIFORNIA 91016 UNITED STATES OF AMERICA

☎ TELEPHONE: (626) 359-8888 FAX: (626) 303-5151

DECLARATION OF CONFORMITY

DECLARATION DE CONFORMITE -DECLARACION DE CONFORMIDAD- ERKLARUNG BEZUGLICH EINHALTUNG DER VORSCHRIFTEN
DICHIARAZIONE DI CONFORMITA . CONFORMITEITSVERKLARING

MANUFACTURED BY:

KENTMASTER MFG CO., INC.
1801 SOUTH MOUNTAIN AVE.
MONROVIA, CALIFORNIA 91016
UNITED STATES OF AMERICA
TELEPHONE (818) 359-8888 FAX (818) 303-5151

FABRIQUE PAR:
 FABRICADA POR:
 HERGESTELLT VON:
 FABBRICATO DA:
 VERVAARDIGD DOOR:

TYPE / SERIES: RECIPROCATING QUATERING AND ALL-PURPOSE SAW

TYPE / SERIE:
 TIPO / SERIE:
 TYP / SERIE:
 TIPO / SERIE:
 TYPE / SERIE:

MODEL: ZIP SAW

MODELE:
 MODELO:
 MODELL:
 MODELLO:
 MODEL:

SERIAL NO. RANGE: XXXXX

N SERIE: • GAMA DE No. DE SERIE: • SERIEN-NR.-BEREICH: • NUMERI DI SERIE: • SERIENUMMERS:

This product complies with the following European Community Directives:

Ce produit est conforme aux directives de la Communauté européenne suivantes:
 Este producto cumple con las siguientes Directrices de la Comunidad Europea:
 Dieses Produkt erfüllt die folgenden Vorschriften der Europäischen Gemeinschaft:
 Questo prodotto è conforme alle seguenti direttive CEE:
 Dit produkt voldoet aan de volgende EG-richtlijnen:

89/392/EEC, 91/368/EEC, 93/44/EEC, 93/68/EEC

The following Standards were used to verify compliance with the Directives:

Les normes suivantes ont été utilisées pour vérifier la conformité avec les Directives:
 Las siguientes Normas se usaron para verificar el cumplimiento de las Directrices:
 Folgende Normen wurden angewandt, um Erfüllung der Vorschriften zu bestätigen:
 Per verificare la conformità del prodotto alle direttive sono stati usati i seguenti standard:
 De volgende normen zijn gebruikt om naleving van de richtlijnen te bevestigen:

EN 292

Approved by:

 RALPH KARUBIAN MONROVIA, CA. U.S.A

Approuvé par:
 Aprobado por:
 Genehmigt von:
 Approvato da:

Goedgekeurd door: _____

RAY PETO MONROVIA, CA. U.S.A

(Engineering Manager) (Directeur technique) (gerente de ingeniería) (verantwortlicher Konstruktionsleiter) (Responsabile tecnico) (ondersteunend technisch mangar)

Date: SEP-03-2002

Date:
 Fecha:
 Datum:
 Data:

Datum: SEP-03-2002

Kentmaster Worldwide Location

Kentmaster Equipment (Aust) PTY.LTD.
Unit 2,24 Central Court
Browns Plains Qld. 4118
Australia

Telephone: (07) 3806-8400
Fax: (07) 3806-7933
Australia@Kentmaster.com

Kentmaster do Brasil, Ltda.
Av. Dr. Joao Teodoro No. 805
Bairro De Vila Rezende
13405-240 Piracicaba, SP,
Brazil

Telephone #1: (019) 3 413 3113
Telephone #2: (019)983-4973
Fax: (019) 3 413 3113
Brazil@Kentmaster.com

Kentmaster (IRL) LTD.
Benamore, Dublin Road.
Roscrea,
CO, Tipperary,
Ireland

Telephone: (353) 0505-23292
Fax: (353) 0505-23299
Ireland@Kentmaster.com

Kentmaster Equipment (NZ) LTD.
5 Cooper Street
Havelock North
New Zealand

Telephone #1: (64) 6 8777 857
Telephone #2: 0800 KENTMASTER
Fax: (64) 6 8777 858
NewZealand@Kentmaster.com

Kentmaster South Africa (PTY) LTD.
Johannesburg - S. Africa
Unit 54 Sunnyrock Park
Sunrock Close, Germiston
South Africa

Telephone: (27) 11-455-3748
Fax: (27) 11-455-3749
SouthAfrica@Kentmaster.com

Kentmaster (UK) LTD.
Unit 16 Avonbank Ind. Centre
West Town Rd, Avonmouth-Bristol,
BS11 9DE
England

Telephone: (44) 117-923-5035
Fax: (44)-117-932-9010
UK@Kentmaster.com

Kentmaster Mfg. Co., Inc.
1801 South Mountain Ave.
Monrovia, CA, 91016
USA

Telephone #1: (626) 359-8888
Telephone #2: (800) 421-1477
Fax: (626) 303-5151
info@Kentmaster.com

Kentmaster Omaha
4417 South 139th Street
Omaha, NE, 68137
USA

Telephone #1: (402) 896-3355
Telephone #2: (800) 367-3181
Fax: (402) 896-3311
Omaha@Kentmaster.com

INDEX

ZIP SAW ASSEMBLY.....	6
MOTOR ASSEMBLY.....	8
CASE ASSEMBLY.....	10
REAR HANDLE ASSEMBLY.....	16
FRONT HANDLE ASSEMBLY.....	18
HANGER ASSEMBLY.....	18
BLADE AND BLADE SUPPORT OPTIONS.....	19
RECOMMENDED SPARE PARTS SHORT-TERM MAINTENANCE.....	20
Figure 1 1900000: ZIP SAW ASSEMBLY.....	6
Figure 2 1900000: BOM, ZIP SAW ASSEMBLY	7
Figure 3 1900500-: MOTOR ASSEMBLY.....	8
Figure 4 1900500: BOM, MOTOR ASSEMBLY.....	9
Figure 5 1900100: CASE ASSEMBLY.....	10
Figure 6 1900100: BOM, CASE ASSEMBLY.....	11
Figure 7 1901010: UPPER CASE.....	11
Figure 8 1901100: CON ROD.....	12
Figure 9 1901250: COUNTER BALANCE ASS'Y.....	12
Figure 10 1901430: GUIDE ASSEMBLY.....	13
Figure 11 1901500: CARTRIDGE – BEARING ASSEMBLY.....	13
Figure 12 1901600: BLADE SHAFT ASSEMBLY.....	14
Figure 13 1902800: GEAR AND BEARING RING ASSEMBLY.....	15
Figure 14 1901400: GEAR ASSEMBLY.....	15
Figure 15 1900800: REAR HANDLE ASSEMBLY.....	16
Figure 16 1900900: TOP - REAR HANDLE.....	17
Figure 17 1902600: SWITCH ASSEMBLY.....	17
Figure 18 1902500: FRONT HANDLE ASSEMBLY.....	18
Figure 19 1902400: HANGER ASSEMBLY.....	18
Figure 20 BLADE SUPPORT.....	19