

REVISIONS			
REV	DESCRIPTION	DATE	CHANGED BY
B	6821000 REPLACED WITH 6821200	04/15	MV

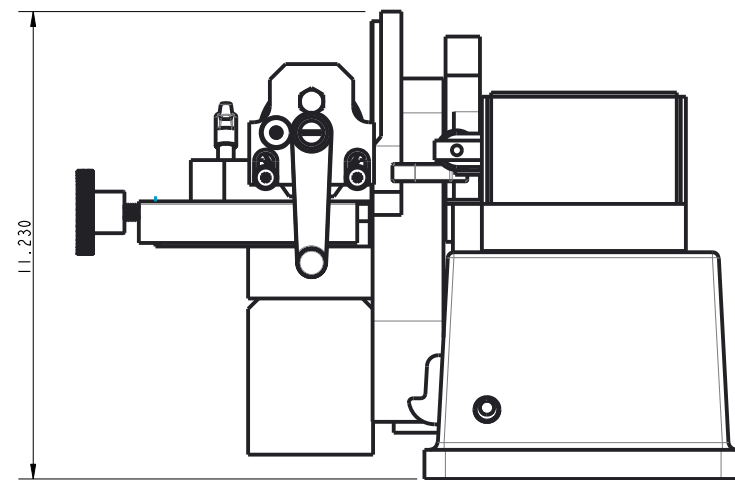
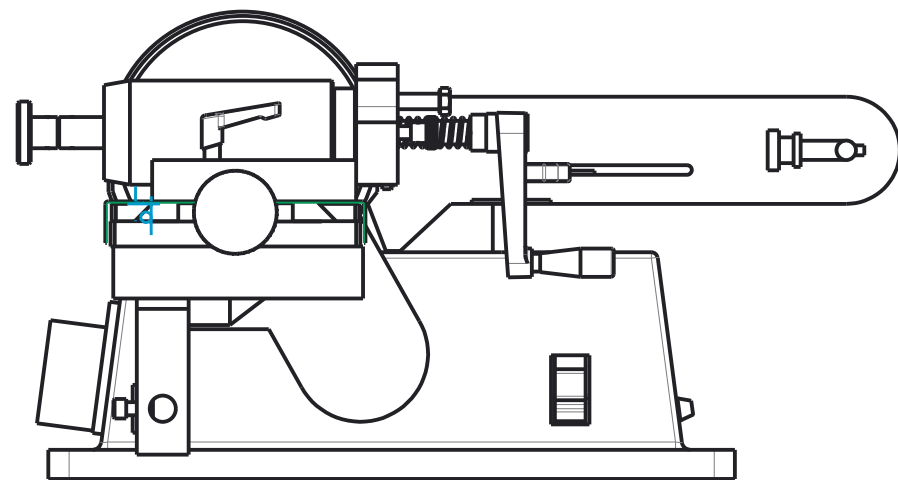
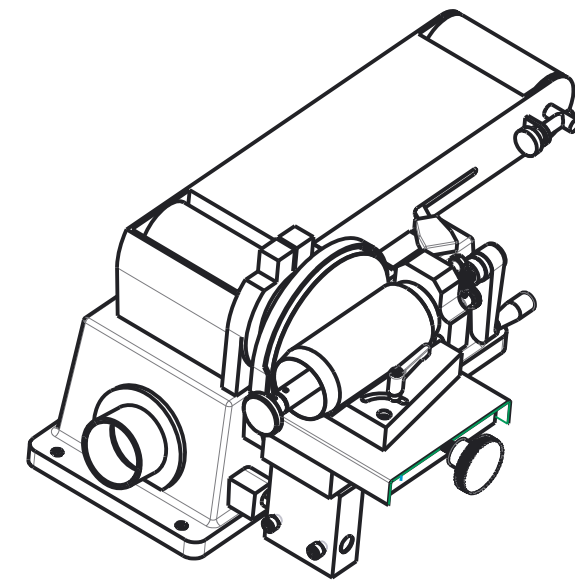
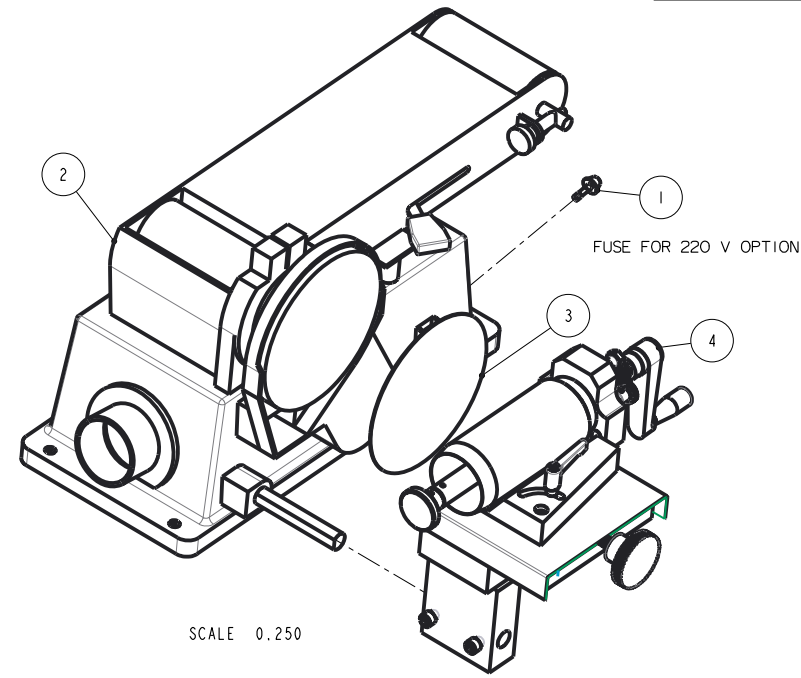
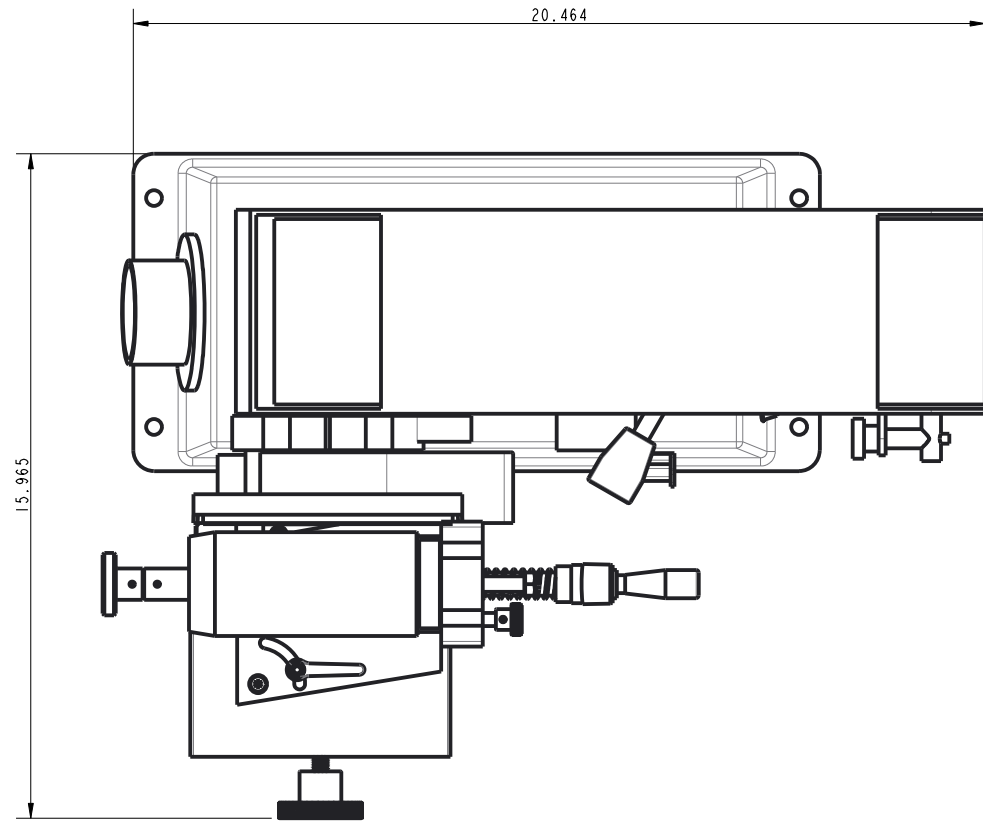

ITEM	PART #	DESCRIPTION	QTY
4	6821200	BLADE GRINDER SUPPORT	1
3	4520010	6" DIA SAND DISC	1
2	4520000	SANDER 4" BELT/ 6" DISC, 1/3HP, 1PH, 115V	1
1	2009430	FUSE 5AMPS, 250V	1

TOLERANCE UNLESS OTHERWISE SPECIFIED

FRACTION	DECIMAL	ANGLE
±1/32	.XX ± .01	±1/2°
	.XXX ± .005	

CONCENTRICITY SQUARE WITHIN PARALLEL WITHIN
 .005 T.I.R. .005 /FT .005 /FT

MACHINE SURFACE FINISH 125 RMS MINIMUM
 BREAK ALL SHARP EDGES
 REMOVE ALL BURRS
 CHAMFER ALL HOLES .015 X 45°

KENTMASTER MFG., CO., INC.
 1801 SOUTH MOUNTAIN AVE. MONROVIA, CA 91016

TITLE: **BUNG GUN BLADE SHARPENER ASSEMBLY**

REF. NO: 6800000	SCALE: 0.350	PART #	REV.
DESIGNED BY: RP	DATE: 24-Oct-02	6820000	B
DRAWN BY: MV/RP	DATE: 24-Oct-02	WEIGHT:	SHEET 1 OF 1

REVISIONS			
REV	DESCRIPTION	DATE	CHANGED BY

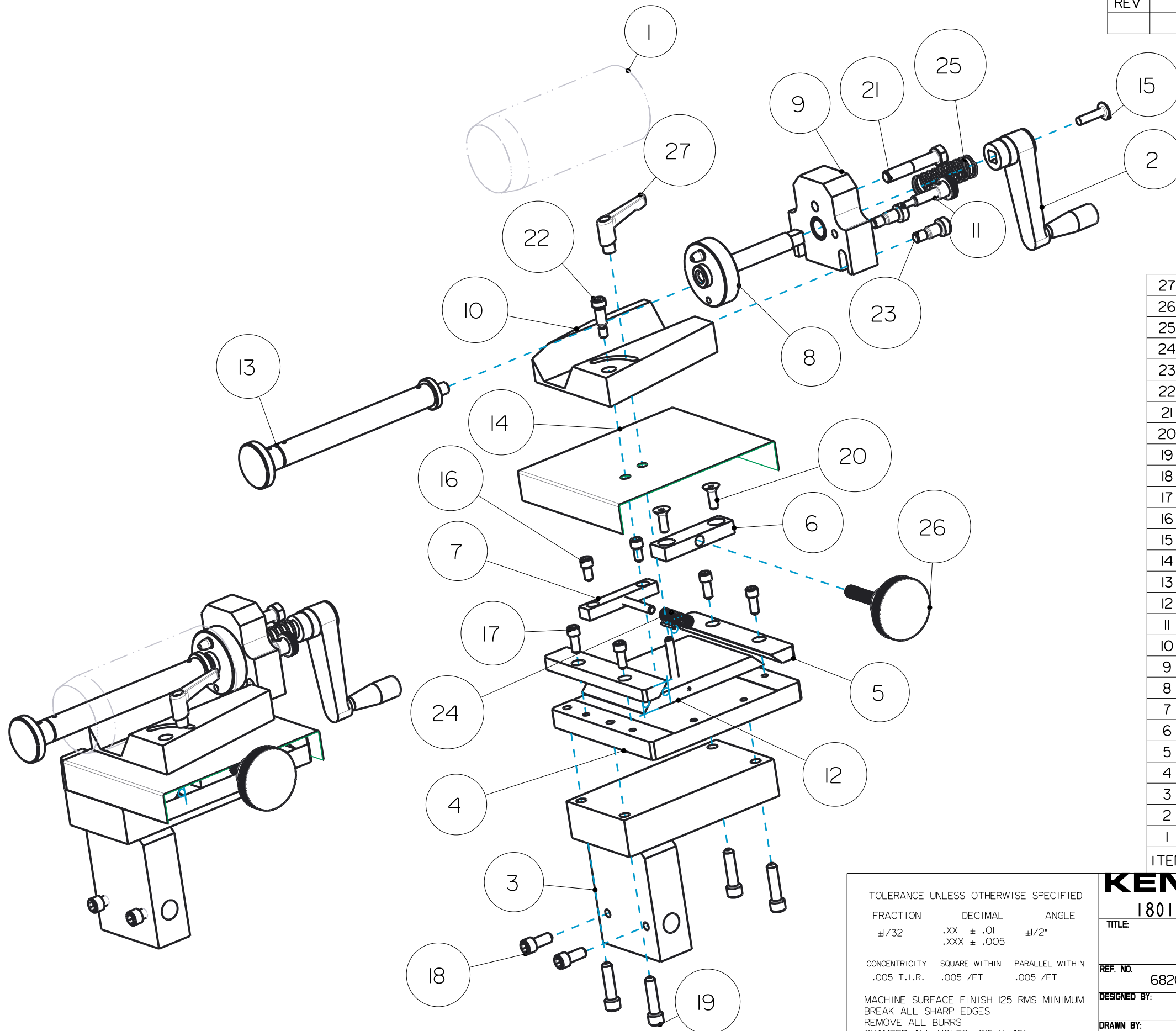

27	8896390	LOCKING HANDLE	1
26	8896370	KNOB	1
25	8890090	SPRING	1
24	8890040	SPRING	1
23	8870310	SCREW	2
22	8870220	SCREW	1
21	8415160	SCREW	1
20	8241060	SCREW	2
19	8213100	SCREW	4
18	8213060	SCREW	2
17	8211050	SCREW	4
16	8211040	SCREW	2
15	8111080	SCREW	1
14	6821420	COVER	1
13	6821400	BLADE WRENCH	1
12	6821380	SLIDE	1
11	6821360	BLADE LOCK PIN	1
10	6821330	"V" - BLOCK	1
9	6821320	MOUNTING HEAD ASSEMBLY	1
8	6821300	BLADE MOUNTING PLATE	1
7	6821280	SPRING GUIDE	1
6	6821250	BRACKET	1
5	6821230	GIB	2
4	6821220	MOUNTING PLATE	1
3	6821210	MOUNTING PLATE	1
2	6821050	HANDLE	1
1	4120020	BLADE	-
ITEM	PART #	DESCRIPTION	QTY

TOLERANCE UNLESS OTHERWISE SPECIFIED

FRACTION	DECIMAL	ANGLE
±1/32	.XX ± .01 .XXX ± .005	±1/2°

CONCENTRICITY SQUARE WITHIN PARALLEL WITHIN
.005 T.I.R. .005 /FT .005 /FT

MACHINE SURFACE FINISH I25 RMS MINIMUM
BREAK ALL SHARP EDGES
REMOVE ALL BURRS
CHAMFER ALL HOLES .015 X 45°

KENTMASTER MFG., CO., INC.
1801 SOUTH MOUNTAIN AVE. MONROVIA, CA 91016

TITLE: BLADE GRINDER SUPPORT			
REF. NO. 6820000	SCALE: 0.300	PART # 6821200P	REV. A
DESIGNED BY: ET	DATE: 10/02	WEIGHT: -	
DRAWN BY: MV	DATE: 10-Apr-15	SHEET 1 OF 3	

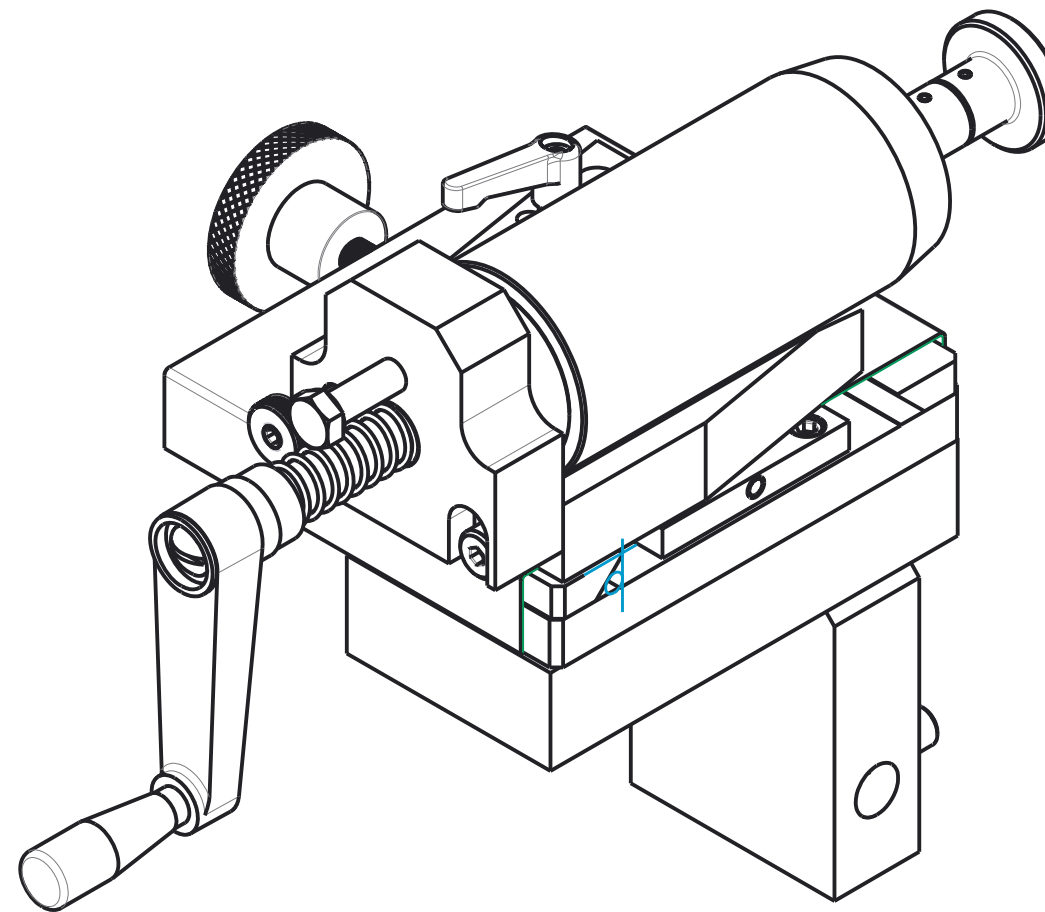
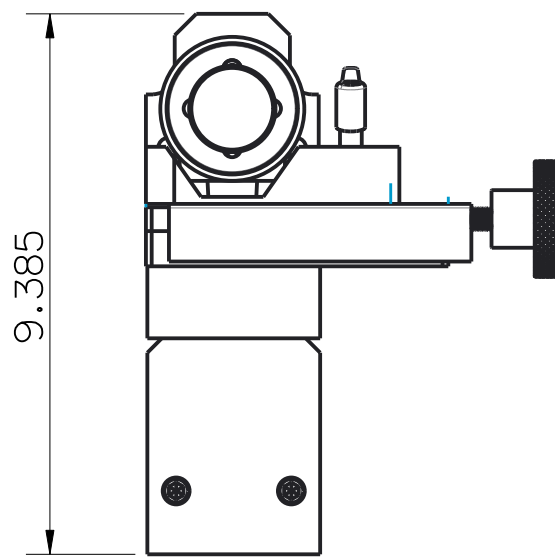
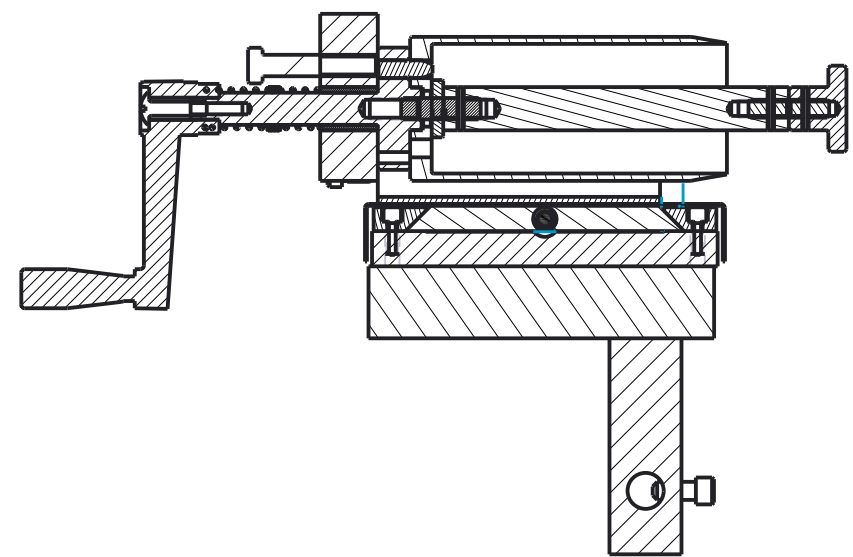
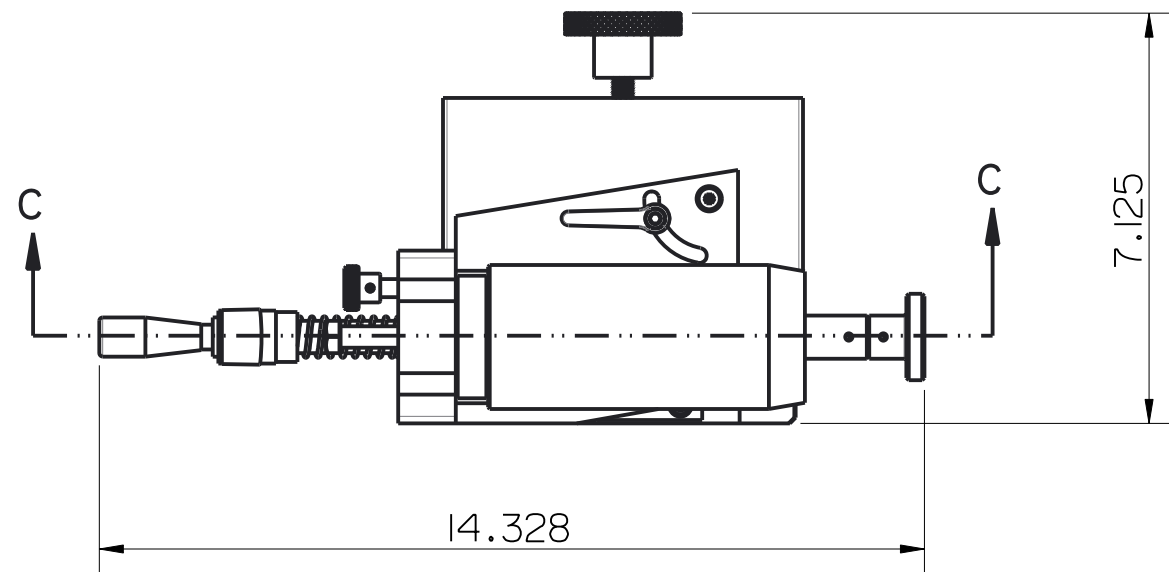

SCALE 0.500

