

OPERATOR'S MANUAL

INCLUDING: OPERATION, INSTRUCTION, INSTALLATION, MAINTENANCE AND PARTSBOOK

**IMPORTANT: READ THIS MANUAL CAREFULLY BEFORE INSTALLING, OPERATING OR
SERVICING THIS TOOL.**

ALL PURPOSE BREAKING SAW "77"

TOOL DATA

MODEL: 77
ASSEMBLY NO. 6001600
TYPE: AIR OPERATED
NET WEIGHT: 22 LBS (10 KG)
INLET AIR PRESSURE: 100 P.S.I. (6-7 BARS)

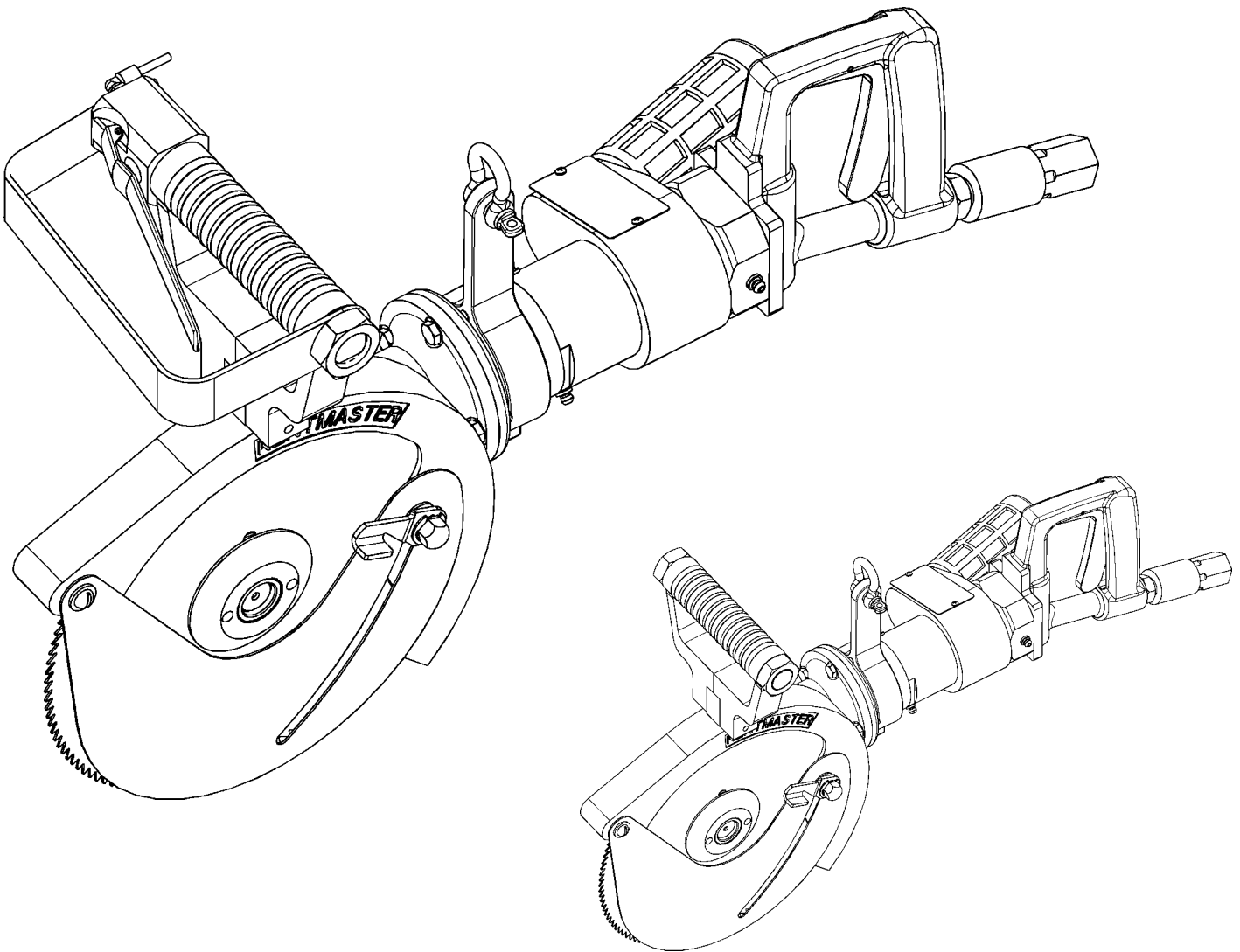

**WARNING**

= Hazards or unsafe practices which could result in severe personal injury, death or substantial property damage.

**CAUTION**

= Hazards or unsafe practices which could result in minor personal injury, product or property damage.

**NOTICE**

= Important installation, operation or maintenance information.

OPERATING AND SAFETY INSTRUCTIONS

**WARNING**

DO NOT OPERATE THIS TOOL UNTIL YOU HAVE READ AND UNDERSTOOD THE SAFETY INSTRUCTIONS AND OPERATING MANUALS.

**WARNING**

DO NOT OPERATE THIS TOOL UNTIL YOU HAVE RECEIVED TRAINING IN THE HANDLING, OPERATION AND USE OF THIS TOOL.

**WARNING**

STOP USING A MALFUNCTIONING OR DEFECTIVE TOOL IMMEDIATELY. REPORT ANY PROBLEMS OR DEFECTS TO YOUR SUPERVISOR FOR REMOVAL OF THE TOOL FROM SERVICE.

**WARNING**

DO NOT ATTEMPT TO REPAIR THE TOOL YOURSELF.

**WARNING**

DO NOT ALLOW UNAUTHORIZED PERSONS TO USE TOOL.

**WARNING**

REMOVE AND DISCONNECT POWER FROM THE TOOL WHEN TOOL IS LEFT UNATTENDED OR IS NOT IN USE.

**WARNING**

NEVER TIE DOWN, BYPASS, ALTER OR MODIFY THE ACTIVATING SWITCHES OR TRIGGERS OF THIS TOOL.

**WARNING**

NEVER MAKE ALTERATIONS OR MODIFICATIONS TO THIS TOOL.

**WARNING**

BE CONSTANTLY AWARE AND ALERT FOR UNSAFE CONDITIONS AND REPORT THEM IMMEDIATELY TO YOUR SUPERVISOR.

**WARNING**

NEVER PLACE YOUR HAND OR ANY PART OF YOUR BODY IN THE CUTTING PATH OF THE TOOL.

**WARNING**

NEVER ALLOW ANYONE ELSE TO PLACE THEIR HANDS OR ANY PART OF THEIR BODY IN THE CUTTING PATH OF THE TOOL.

**WARNING**

DO NOT ACTIVATE CONTROL SWITCHES OR TRIGGERS OF THIS TOOL UNLESS YOU INTEND TO TEST OR OPERATE THIS TOOL.

**WARNING**

DO NOT USE THIS TOOL FOR ANY PURPOSE OTHER THAN IT'S INTENDED PURPOSE.

WHEN OPERATING THIS TOOL WEAR THE PROTECTIVE GEAR AND SAFETY EQUIPMENT SUPPLIED TO YOU.

**CAUTION**

THE NOISE EMISSION (SOUND PRESSURE LEVEL) AT THE WORKSTATION MAY EXCEED 80 dB (A). EAR AND SOUND PROTECTION GEAR IS REQUIRED.

**WARNING**

OPERATING INSTRUCTIONS

⚠ WARNING ONLY TRAINED PERSONNEL ARE TO OPERATE THIS TOOL.

1. TO ENSURE TOOL IS OPERATING PROPERLY, PERFORM FOLLOWING STEPS AT START OF EACH SHIFT:
 - MAKE SURE TOOL MOVES UP AND DOWN FREELY WHILE HANGING FROM BALANCER OVERHEAD.
 - WITH POWER TO TOOL TURNED ON, TEST TRIGGER FOR PROPER OPERATION.
 - DEPRESS EACH TRIGGER SEPARATELY. TOOL SHOULD NOT ACTIVATE. DEPRESS BOTH TRIGGERS. TOOL SHOULD ACTIVATE.
 - IF TOOL HAS "ANTI-TIE DOWN" OPTION, BOTH TRIGGERS MUST BE DEPRESSED SIMULTANEOUSLY FOR TOOL TO ACTIVATE.
2. TO PERFORM WORK, HOLD TOOL FIRMLY AT BOTH HANDLES. SQUEEZE TRIGGERS TO ACTIVATE TOOL.
3. POSITION TOOL AND PERFORM CUTTING OPERATION.

MAINTENANCE

⚠ WARNING ONLY TRAINED AND QUALIFIED PERSONNEL ARE TO PERFORM MAINTENANCE AND SERVICE TO THIS TOOL.

THE COMPRESSED AIR DISTRIBUTION SYSTEM MUST BE LARGE ENOUGH TO SUPPLY AN ADEQUATE VOLUME OF CLEAN AND DRY COMPRESSED AIR TO THE TOOL.

1. MAKE ALL NECESSARY LINE CONNECTIONS TO THE TOOL.
2. AN AIR FILTER-REGULATOR-LUBRICATOR (PART NO. 7200030) MUST BE INSTALLED IN AIR SUPPLY FOR EACH TOOL.
3. FILL LUBRICATOR WITH KENTMASTER AIR MIST OIL (PART NO. 7903050). SET DRIP RATE ACCORDING TO INSTRUCTIONS SUPPLIED. TURN ADJUSTMENT ON SIGHT FEED DOME TO INCREASE/DECREASE OIL DELIVERY. MONITOR THE DEVICE BEING LUBRICATED AND READJUST IF NEEDED.
4. TOOL REQUIRES GREASING AT START OF EACH SHIFT. GREASE FOUR (4) LOCATIONS USING KENTMASTER GREASE GUN (PART NO. 4501470) AND GREASE (PART NO. 7903070).
5. TOOL REQUIRES 40 S.C.F.M. OF AIR @ 90 P.S.I. AIR PRESSURE.
6. FLUSH AIR MOTOR AT END OF EACH DAY'S USE BY SQUIRTING A FEW SQUIRTS OF KENTMASTER AIR OIL MIST (PART 7903050) DIRECTLY INTO THE AIR INLET PORT. RUN TOOL A FEW SECONDS TO COAT AND PROTECT THE AIR MOTOR AND INTERNAL PARTS OF TOOL.

BLADE REMOVAL AND CLEANING.

⚠ WARNING ALWAYS DISCONNECT POWER SUPPLY FROM TOOL BEFORE INSTALLING OR REMOVING BLADE FROM TOOL.

⚠ WARNING ALWAYS WEAR WIRE MESH GLOVES WHEN INSTALLING OR REMOVING BLADE FROM TOOL.

1. REMOVE COLLAR (ITEM NO. 1, FIG. NO. 1).
2. REMOVE BLADE (ITEM NO. 2, FIG. NO. 1).
3. CLEAN ALL PARTS REMOVED WITH SOAP AND WATER.
4. SHARPEN OR REPLACE BLADES WHEN NECESSARY.
5. REASSEMBLE IN REVERSE ORDER.

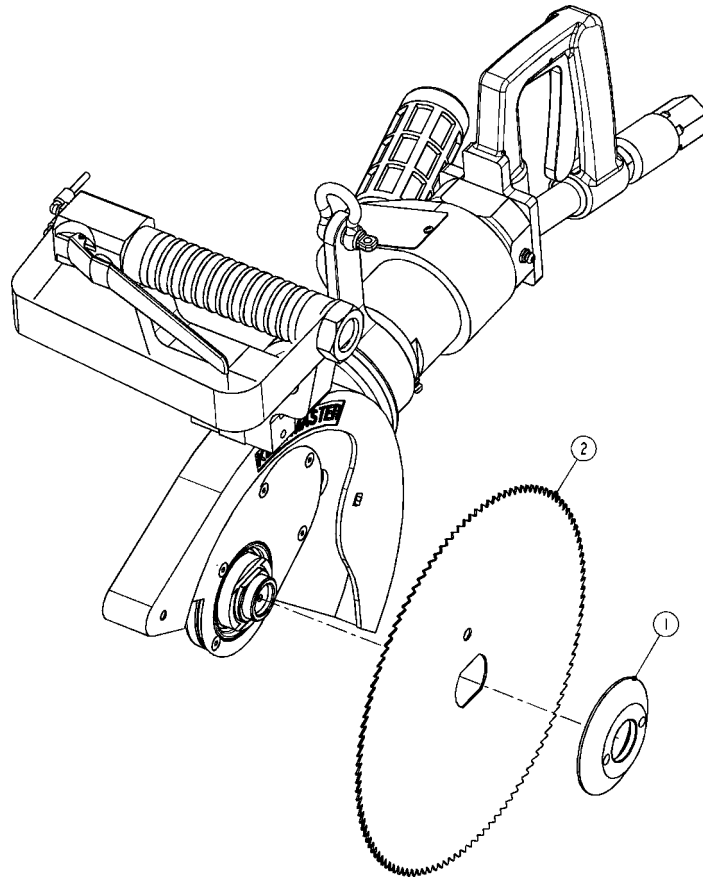

Figure 1 MODEL 77 – BLADE REPLACEMENT

SERVICE

1. KEEP GOOD RECORDS OF ALL SERVICE ACTIVITY AND INCLUDE TOOL IN PREVENTIVE MAINTENANCE PROGRAM.
2. USE ONLY GENUINE KENTMASTER REPLACEMENT PARTS TO ASSURE PROPER PERFORMANCE OF TOOL.
3. CONTACT THE KENTMASTER SUPPLIER NEAREST YOU FOR PARTS AND CUSTOMER SERVICE INFORMATION.



PARTS BOOK

KENTMASTER MFG. CO., INC. 1801 SOUTH MOUNTAIN AVE., MONROVIA, CALIFORNIA 91016 UNITED STATES OF AMERICA

① TELEPHONE: (626) 359-8888 FAX: (626) 303-5151

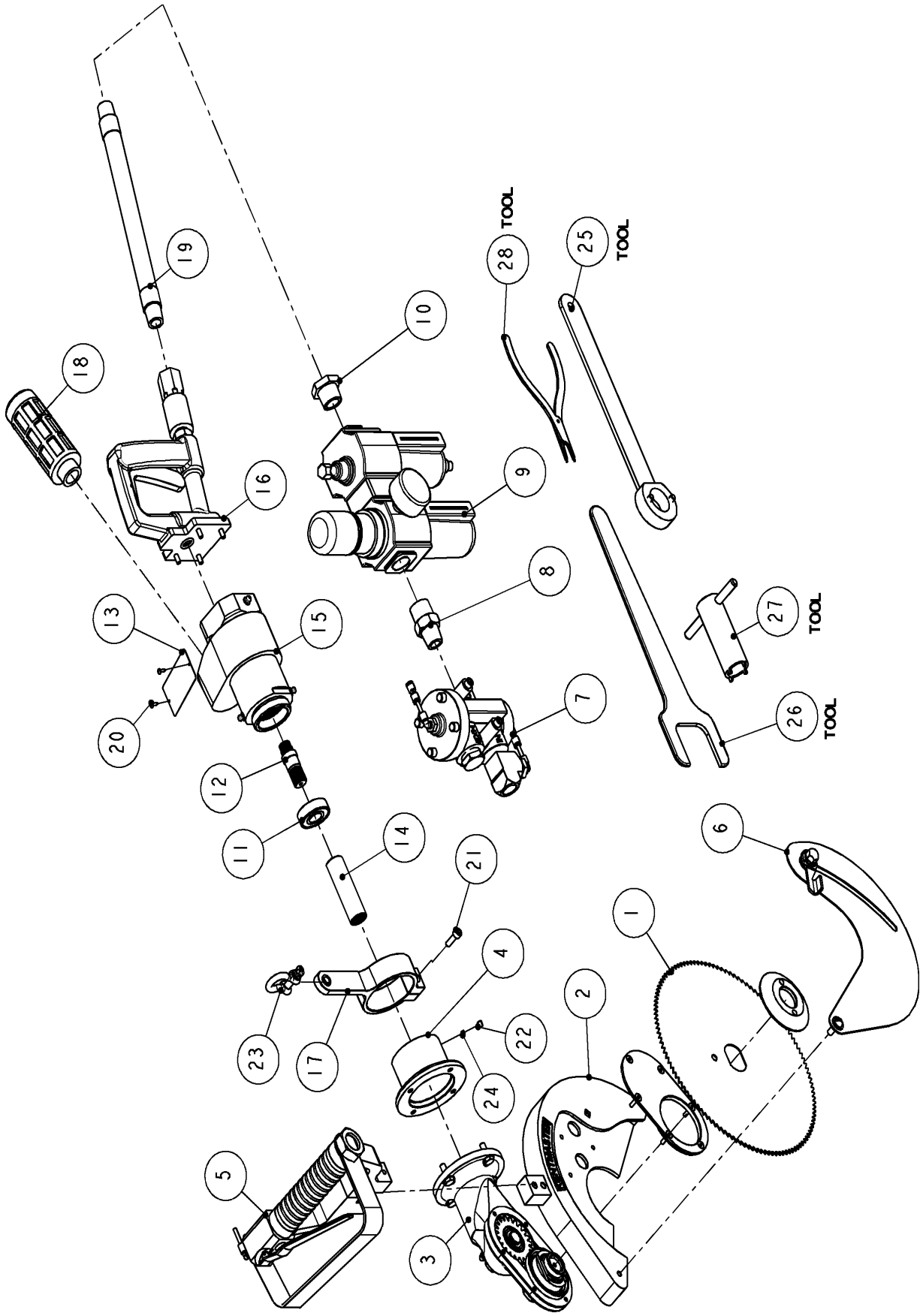

Figure 2 MODEL "77" – MAIN ASSEMBLY

KENTMASTER MFG. CO., INC. 1801 SOUTH MOUNTAIN AVE., MONROVIA, CALIFORNIA 91016 UNITED STATES OF AMERICA
 ☎ TELEPHONE: (626) 359-8888 FAX: (626) 303-5151

6001600: "77" - ALL PURPOSE BREAKING SAW			
ITEM	PART #	DESCRIPTION	QTY
1	4000230	8" SAW BLADE, 150 TEETH	1
	4000110	9" SAW BLADE THIN RIM, 240 TEETH	1
	4000280	10" SAW BLADE, 120 TEETH	1
	4000060	10" SAW BLADE, 220 TEETH	1
	4000080	11" SAW BLADE, 240 TEETH	1
	4000520	12" SAW BLADE, 240 TEETH	1
2	6001160	BLADE GUARD, FOR 8" BLADE	1
	6001170	BLADE GUARD, FOR 9" & 10" BLADE	1
	6001180	BLADE GUARD, FOR 11" & 12" BLADE	1
3	6003131	GEAR-NOSE ASSEMBLY FOR 8", 9" & 10" BLADE	1
	6003160	GEAR-NOSE ASSEMBLY FOR 11" & 12" BLADE	1
4	6001090	SPACER-AIR MOTOR FOR 8", 9" & 10" BLADE	1
	6003170	SPACER-AIR MOTOR FOR 11" & 12" BLADE	1
5	6001140	FRONT HANDLE WITH AIR SWITCH (FOR TWO TRIGGERS OPTION)	1
	6001141	FRONT HANDLE WITHOUT AIR SWITCH (FOR ONE TRIGER OPTION)	1
6	6001191	DEPTH GAUGE FOR 8" BLADE / OPTIONAL	1
	6001190	DEPTH GAUGE FOR 9 & 10" BLADE / OPTIONAL	1
7	6001605	POPPET VALVE ASSEMBLY / OPTIONAL	1
8	7002680	ADAPTER / OPTIONAL	1
9	7200030	REGULATOR/FILTER/LUBRICATOR / OPTIONAL	1
10	7002450	BUSHING / OPTIONAL	1
11	3204030	BEARING	1
12	6000170	DRIVE SHAFT	1
13	6000590	NAME PLATE	1
14	6001250	COUPLING	1
15	6001400	AIR MOTOR AND GEAR CASE ASSEMBLY	1
16	6003140	REAR HANDLE ASSEMBLY	1
17	6003220	HANGER RING	1
18	6330160	MUFFLER	1
19	7310040	AIR HOSE	1
20	8081020	SCREW	2
21	8211060	SCREW	1
22	8311020	SET SCREW	1
23	8462020	ANCHOR SHACKLE	1
24	8703010	PLUG	1
25	4501610	WRENCH / INCLUDED	1
26	4501300	WRENCH – AIR MOTOR, GEAR CASE / OPTIONAL	1
27	4501320	SPANNER WRENCH AND HANDLE / OPTIONAL	1
28	4501350	RATAINING RING PLIER / OPTIONAL	1

MODEL "77" WITH TWO TRIGGERS (FRONT HANDLE #6001140) REQUIRES POPPET VALVE (#6001605). AN AIR FILTER-REGULATOR-LUBRICATOR (#7200030) MUST BE INSTALLED IN AIR SUPPLY FOR EACH TOOL.

Figure 3 BOM FOR MODEL "77"

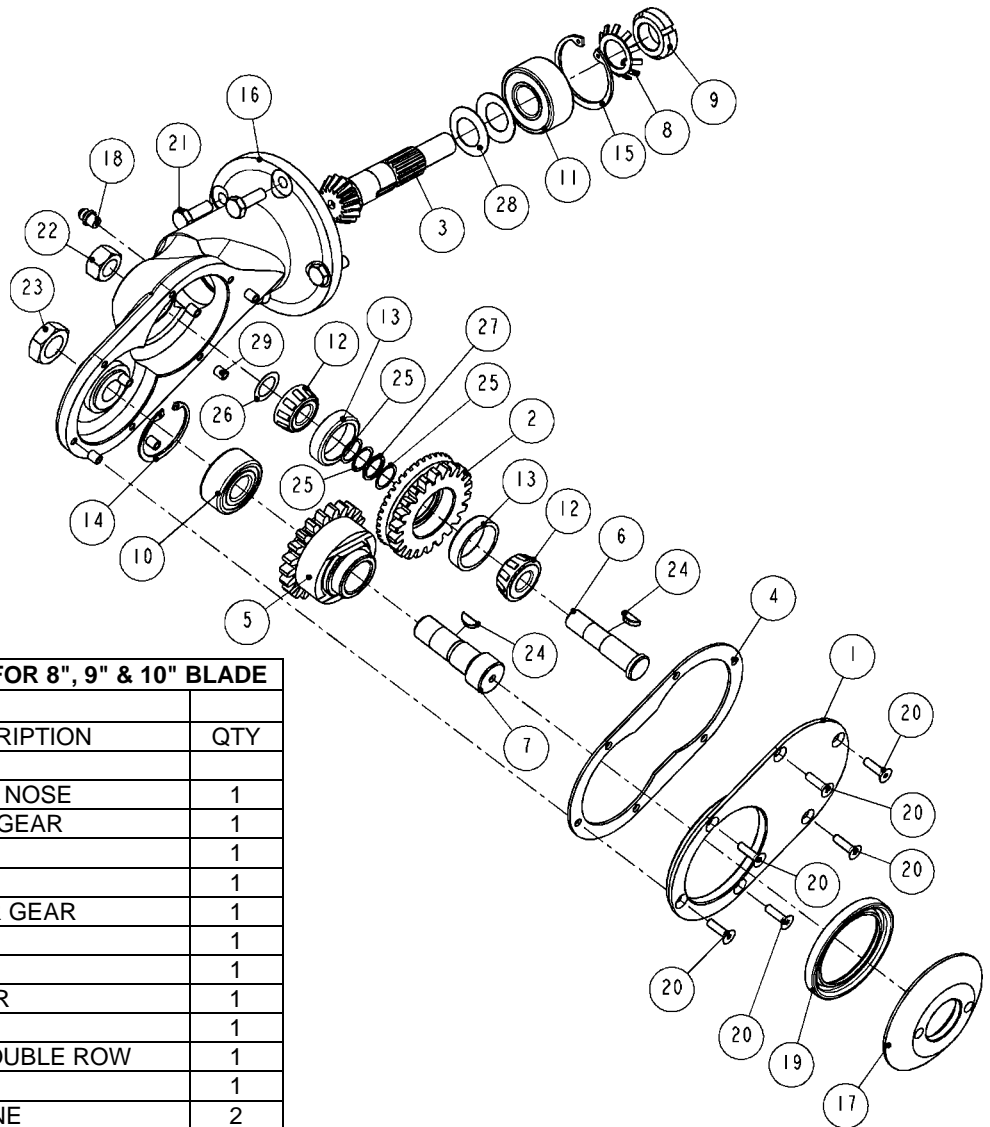

6003131: GEAR-NOSE ASSEMBLY FOR 8", 9" & 10" BLADE			
ITEM	PART #	DESCRIPTION	QTY
1	1000360	COVER GEAR NOSE	1
2	1000400	BEVEL/SPUR GEAR	1
3	1000410	PINION	1
4	1000440	GASKET	1
5	1000740	DRIVEN SPUR GEAR	1
6	1001520	SHAFT	1
7	1001530	SHAFT	1
8	3000030	LOCKWASHER	1
9	3001030	LOCKNUT	1
10	3521020	BEARING - DOUBLE ROW	1
11	3524030	BEARING	1
12	3650020	BEARING CONE	2
13	3650030	BEARING CUP	2
14	5001370	RETAINING RING	1
15	5001560	RETAINING RING	1
16	6003080	GEAR NOSE HOUSING	1
17	6003180	NUT - BLADE	1
18	7017110	GREASE FITTING	1
19	7885580	SEAL	1
20	8270530	SCREW	6
21	8411060	SCREW	4
22	8500470	NUT	1
23	8500520	NUT	1
24	8600440	KEY	2
25	8705000	WASHER	3
26	8705010	WASHER	1
27	8705470	WASHER	1
28	8712030	SPRING WASHER	2
29	8803080	INSERT	6

Figure 4 GEAR-NOSE ASSEMBLY FOR 8", 9" & 10" BLADE

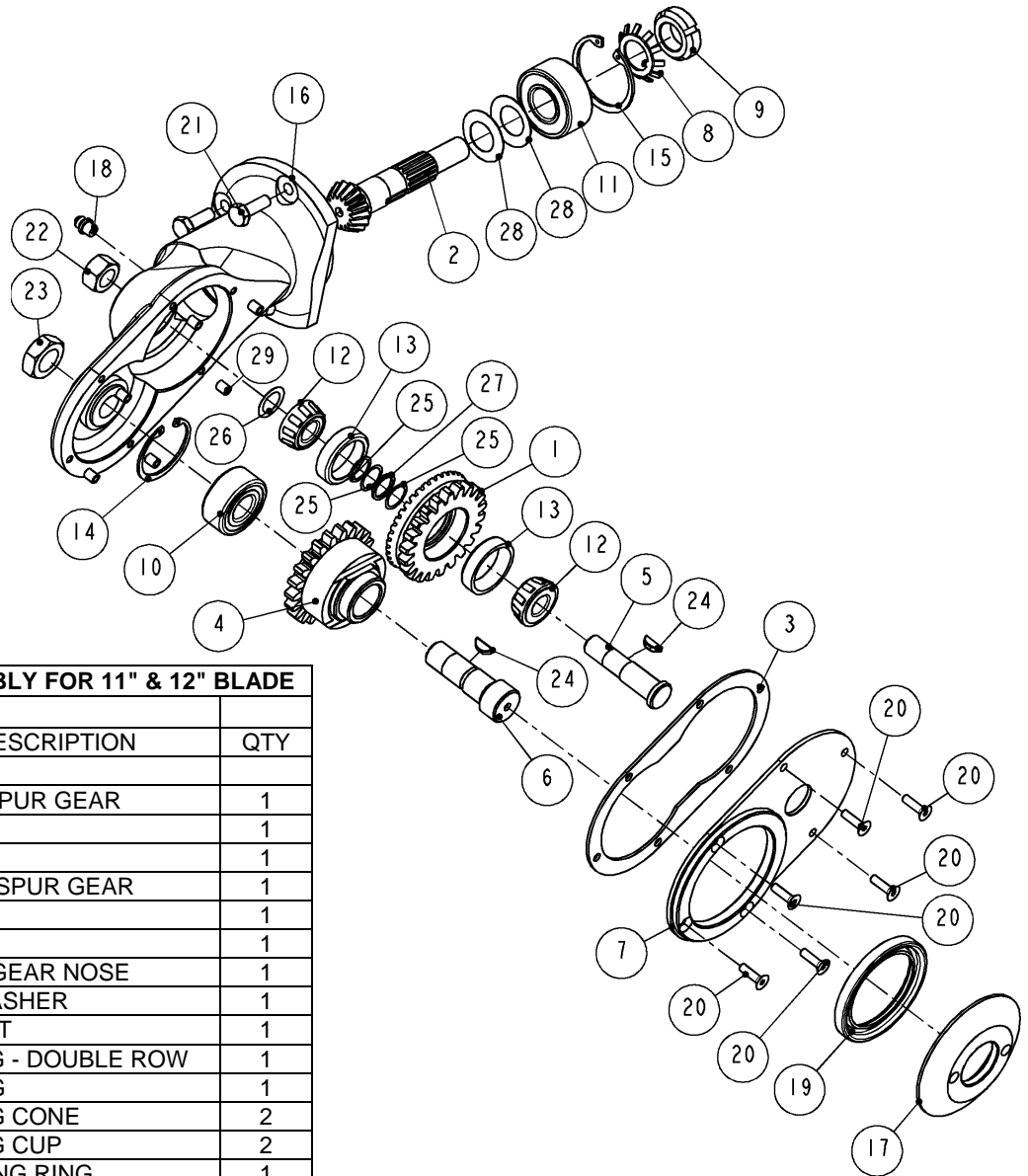

6003160: GEAR NOSE ASSEMBLY FOR 11" & 12" BLADE

ITEM	PART #	DESCRIPTION	QTY
1	1000400	BEVEL/SPUR GEAR	1
2	1000410	PINION	1
3	1000440	GASKET	1
4	1000740	DRIVEN SPUR GEAR	1
5	1001520	SHAFT	1
6	1001530	SHAFT	1
7	1001580	COVER GEAR NOSE	1
8	3000030	LOCKWASHER	1
9	3001030	LOCKNUT	1
10	3521020	BEARING - DOUBLE ROW	1
11	3524030	BEARING	1
12	3650020	BEARING CONE	2
13	3650030	BEARING CUP	2
14	5001370	RETAINING RING	1
15	5001560	RETAINING RING	1
16	6003150	GEAR NOSE HOUSING	1
17	6003180	NUT - BLADE	1
18	7017110	GREASE FITTING	1
19	7885580	SEAL	1
20	8270530	SCREW	6
21	8411060	SCREW	3
22	8500470	NUT	1
23	8500520	NUT	1
24	8600440	KEY	2
25	8705000	WASHER	3
26	8705010	WASHER	1
27	8705470	WASHER	1
28	8712030	SPRING WASHER	2
29	8803080	INSERT	6

Figure 5 GEAR-NOSE ASSEMBLY FOR 11" & 12" BLADE

GEAR HOUSING DISASSEMBLY

1. REMOVE (2) NUTS, ITEMS 22 & 23 (FIGURE 4).
2. FROM REAR OF NOSE, ITEM 16, PRESS OUT SHAFT, ITEM 7, FIRST.
3. FROM REAR OF NOSE, ITEM 16, PRESS OUT SHAFT, ITEM 6, NEXT.
4. REMOVE RETAINING RING, ITEM 15.
5. FROM FRONT FACE OF NOSE, ITEM 16, PRESS OUT PINION, ITEM 3.
6. FOLD BACK LOCKWASHER TAB, ITEM 8, OUT OF LOCKNUT SLOT, ITEM 9.
7. USING LOCKNUT WRENCH (OPTIONAL), ITEM 27 (FIGURE 2), REMOVE LOCKNUT, ITEM 9 (FIGURE 4).

GEAR HOUSING REASSEMBLY

1. CLEAN AND LUBRICATE ALL PARTS PRIOR TO REASSEMBLY.
2. REASSEMBLE PARS IN REVERSE ORDER.
3. BE SURE TO REASSEMBLE (4) SPRING WASHER, ITEM 28 (FIGURE 4), ONTO PINION, ITEM 3, IN CORRECT ORIENTATION

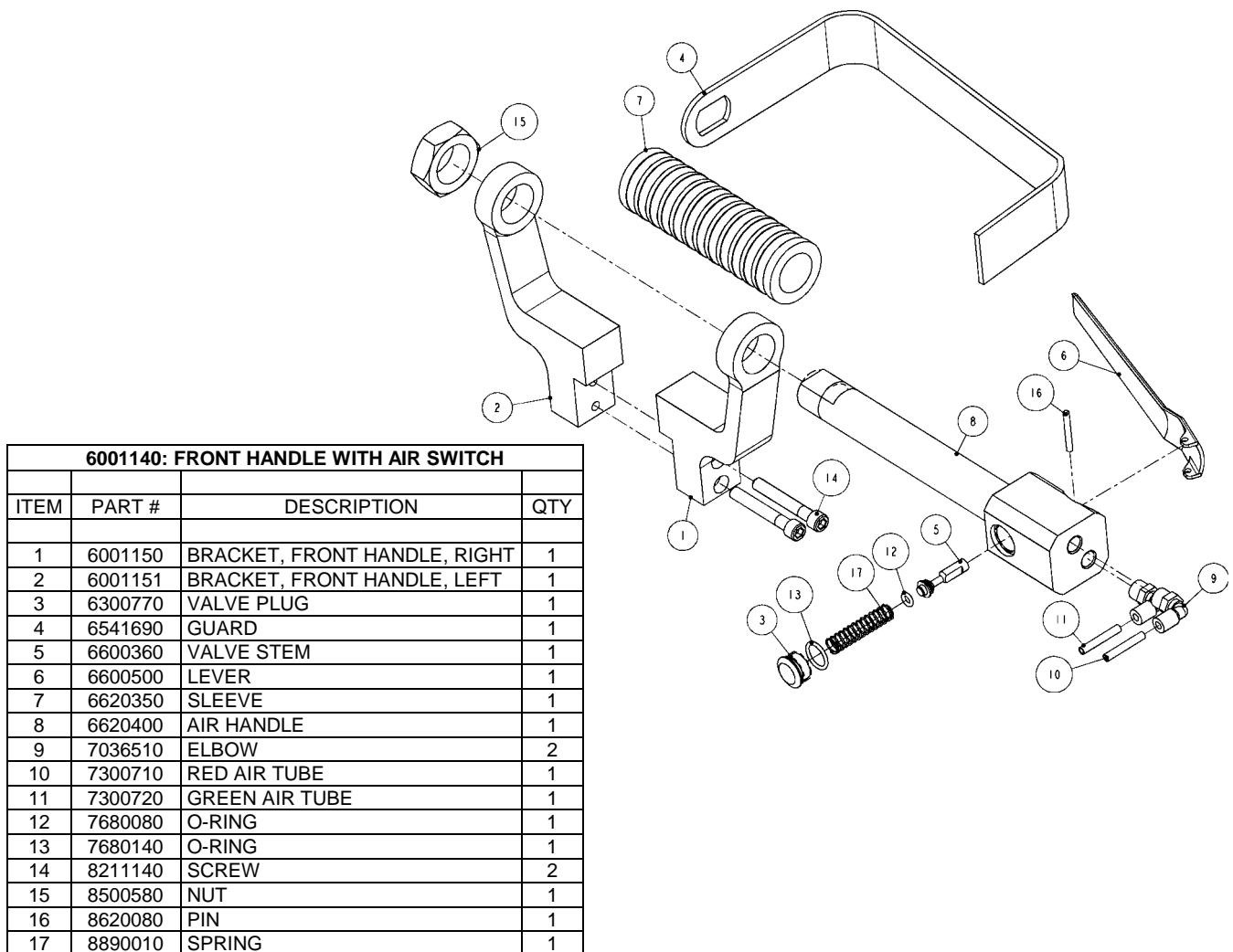

FRONT HANDLE WITH AIR SWITCH (#6001140) REQUIRES POPPET VALVE (#6001605).

Figure 6 FRONT HANDLE WITH AIR SWITCH

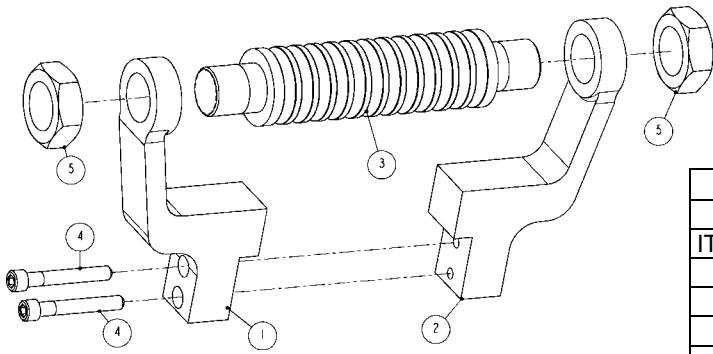

6001141: FRONT HANDLE WITHOUT SWITCH			
ITEM	PART #	DESCRIPTION	QTY
1	6001150	BRACKET, FRONT HANDLE, RIGHT	1
2	6001151	BRACKET, FRONT HANDLE, LEFT	1
3	6550710	CROSS BAR, HANDLE	1
4	8211140	SCREW	2
5	8500580	NUT	2

Figure 7 FRONT HANDLE WITHOUT SWITCH

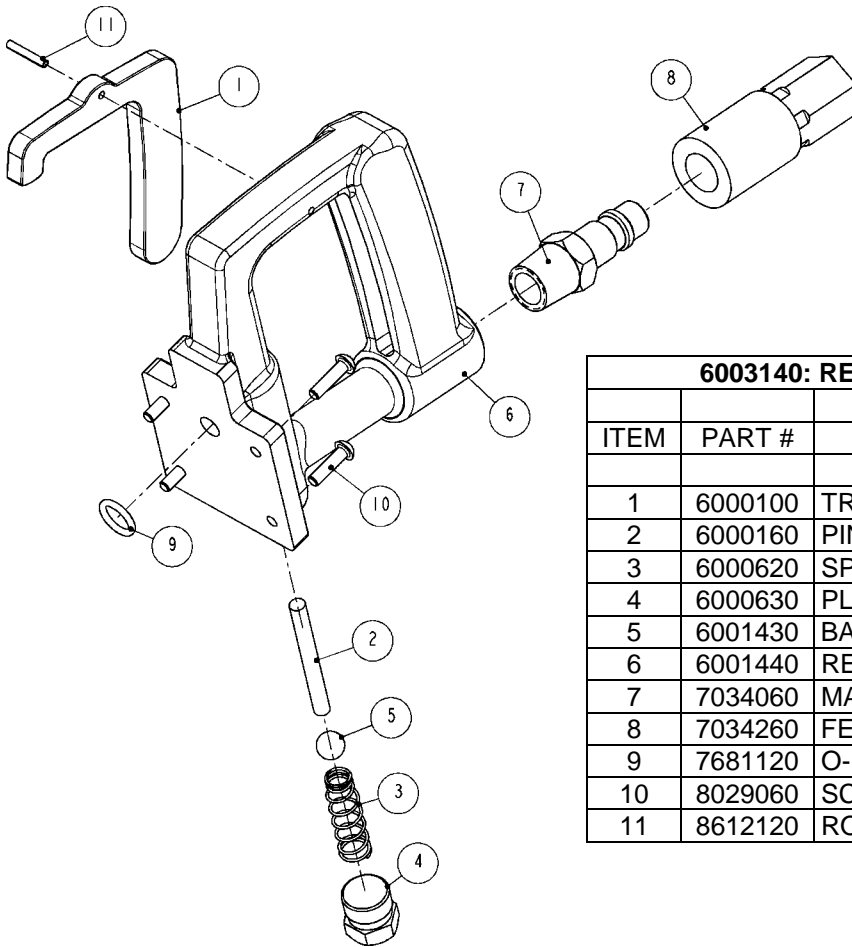

6003140: REAR HANDLE ASSEMBLY			
ITEM	PART #	DESCRIPTION	QTY
1	6000100	TRIGGER	1
2	6000160	PIN	1
3	6000620	SPRING	1
4	6000630	PLUG	1
5	6001430	BALL, AIR VALVE SEAL	1
6	6001440	REAR HANDLE	1
7	7034060	MALE QUICK CONNECT	1
8	7034260	FEMALE SOCKET	1
9	7681120	O-RING	1
10	8029060	SCREW	4
11	8612120	ROLL PIN	1

Figure 8 REAR HANDLE ASSEMBLY

6001400: AIR MOTOR AND GEAR CASE ASSEMBLY			
ITEM	PART #	DESCRIPTION	QTY
1	6000940	DEFLECTOR	1
2	6001010	GEAR CASE ASSEMBLY	1
3	6001450	AIR MOTOR ASSEMBLY	1
4	7680360	O-RING	2
5	8311030	SET SCREW	1

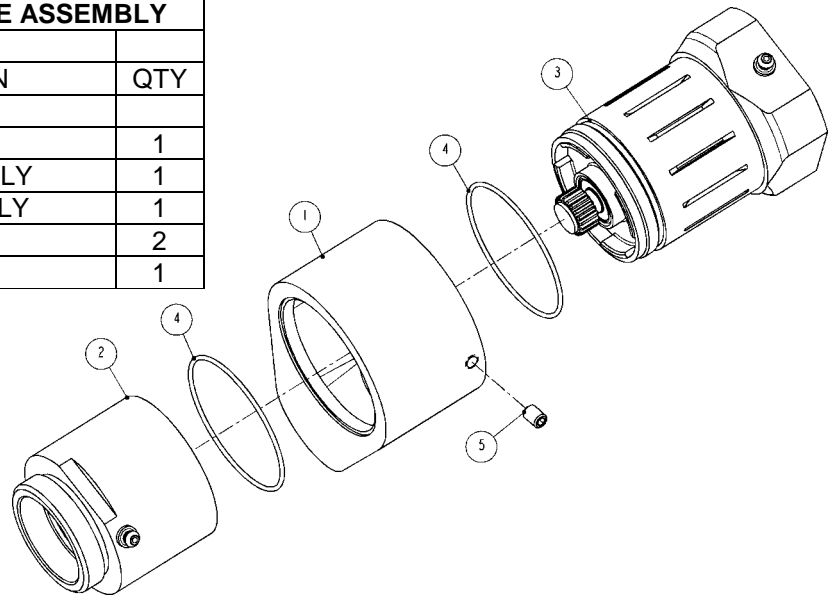
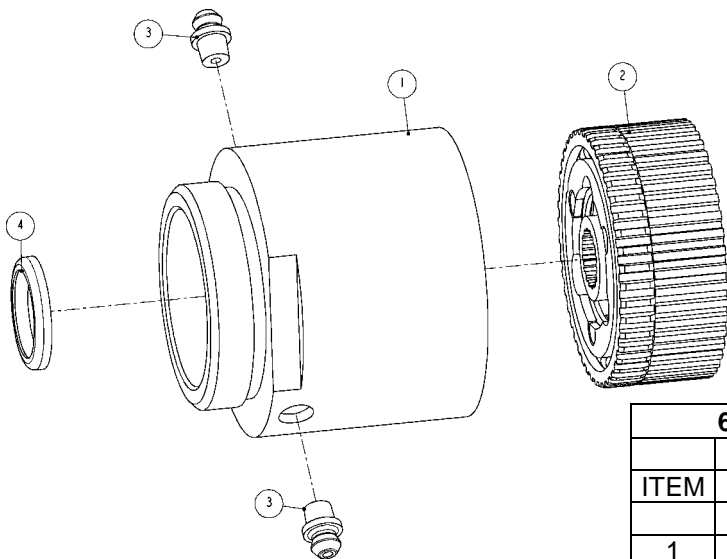
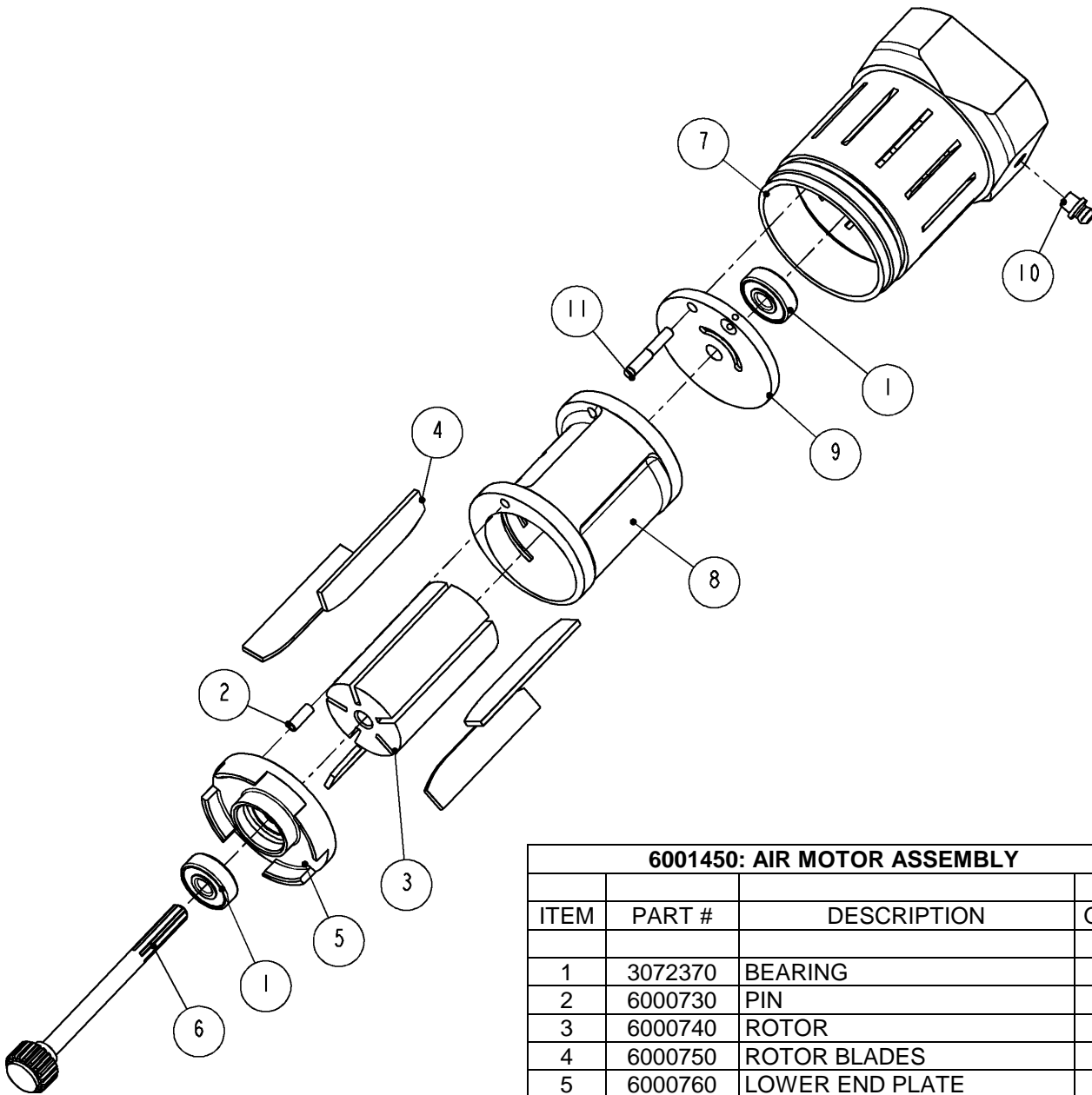

Figure 9 AIR MOTOR AND GEAR CASE ASSEMBLY



6001010: GEAR CASE ASSEMBLY			
ITEM	PART #	DESCRIPTION	QTY
1	6000860	GEAR CASE	1
2	6001030	GEAR CAGE	1
3	7017110	GREASE FITTING	2
4	7774100	SEAL	1

Figure 10 GEAR CASE ASSEMBLY



6001450: AIR MOTOR ASSEMBLY			
ITEM	PART #	DESCRIPTION	QTY
1	3072370	BEARING	2
2	6000730	PIN	1
3	6000740	ROTOR	1
4	6000750	ROTOR BLADES	5
5	6000760	LOWER END PLATE	1
6	6001020	LONG GEAR SPINDLE	1
7	6001100	HOUSING, AIR MOTOR	1
8	6001460	CYLINDER	1
9	6001470	UPPER END PLATE	1
10	7017110	GREASE FITTING	1
11	8641580	GROOVED PIN	1

Figure 11 AIR MOTOR ASSEMBLY

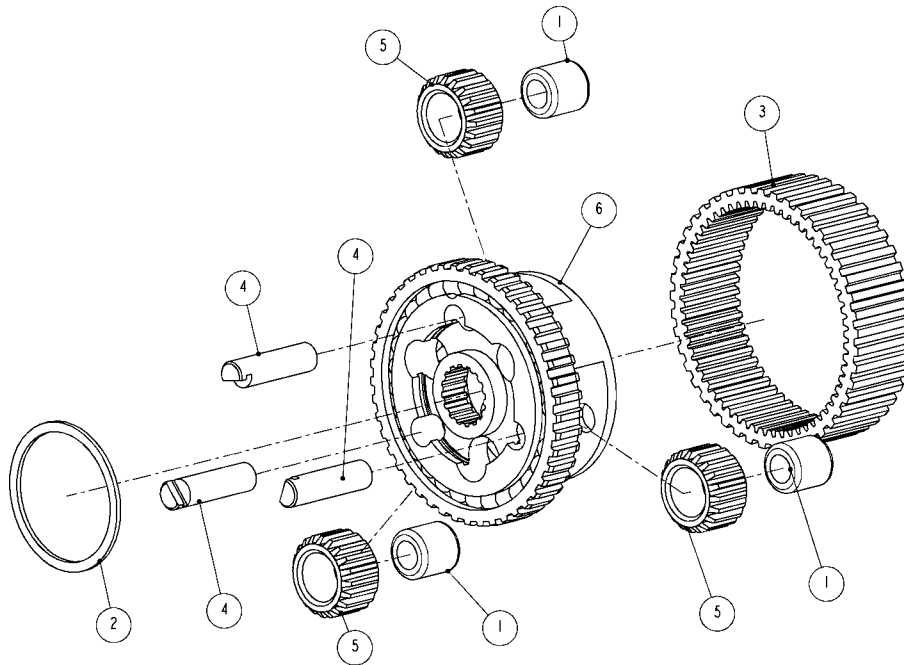

6001030: GEAR CAGE ASSEMBLY			
ITEM	PART #	DESCRIPTION	QTY
1	3700470	NEEDLE BEARING	3
2	5601250	RETAINING RING	1
3	6000790	RING GEAR	1
4	6001040	PIN	3
5	6001050	IDLER GEAR	3
6	6001060	GEAR CAGE AND SPLINE RING ASSEMBLY	1

Figure 12 GEAR CAGE ASSEMBLY

GEAR CASE AND AIRMOTOR DISASSEMBLY

1. LOOSEN SET SCREW, ITEM 5 (FIGURE 9).
2. USIN WRENCH (OPTIONAL), ITEM 26 (FIGURE 2), REMOVE CASE, ITEM 2 (FIGURE 9).
3. TO DISASSEMBLE GEAR CAGE ASSEMBLY:
 - REMOVE RETAINING RING, ITEM 2 (FIGURE 12).
 - PRESS OUT PINS (3) AND BEARINGS (3), ITEMS 4 AND 1 (FIGURE 12).
4. SLIDE DEFLECTOR, ITEM 1 (FIGURE 9), OFF HOUSING, ITEM 3 (FIGURE 9).
5. SLIDE AIR MOTOR OUT OF HOUSING, ITEM 7 (FIGURE 11).
6. PULL GEAR, ITEM 6 (FIGURE 11), OUT OF AIR MOTOR.
7. PULL PLATES, ITEMS 5 AND 9 (FIGURE 11), OFF CYLINDER, ITEM 8 (FIGURE 11).

GEAR CASE AND AIRMOTOR REASSEMBLY

1. CLEAN AND LUBRICATE ALL PARTS PRIOR TO REASSEMBLY.
2. REASSEMBLE ALL PARTS IN REVERSE ORDER.
3. HAND TIGHTEN CASE, ITEM 2 (FIGURE 9), ONTO HOUSING, ITEM 3 (FIGURE 9).
4. ATTACH AIR TO TOOL. WITH TOOL ACTIVATED, TIGHTEN WITH A WRENCH, CASE ONTO HOUSING. THIS HELPS MAINTAIN THE ALIGNMENT OF AIRMOTOR TO GEAR CASE ASSEMBLY. DISCONNECT AIR SUPPLY.

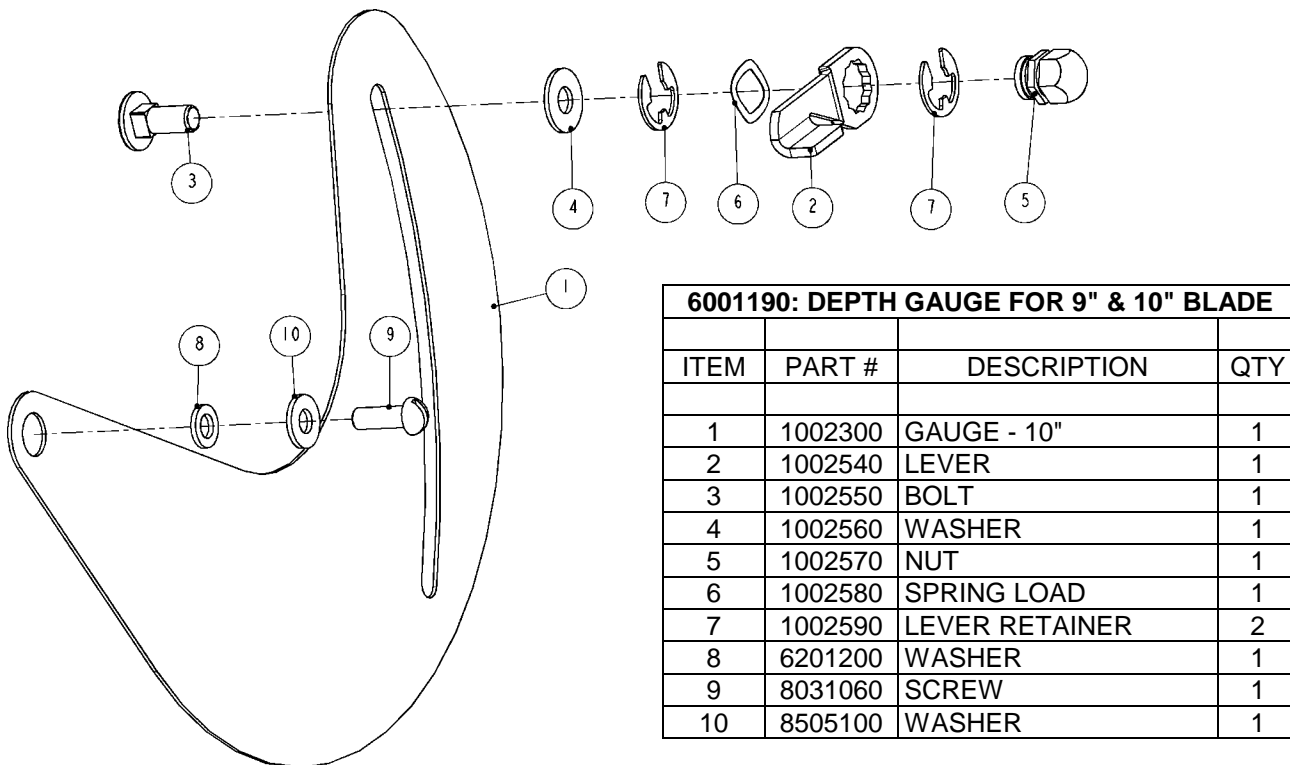

Figure 13 DEPTH GAUGE FOR 9" & 10" BLADE

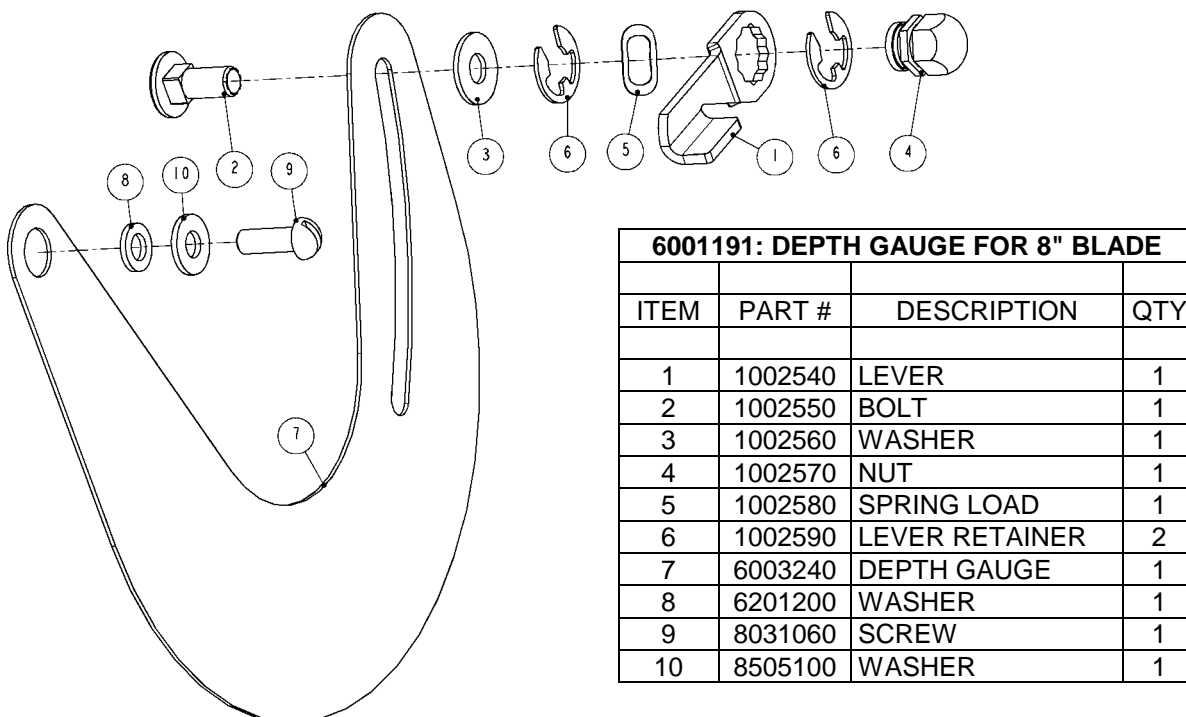
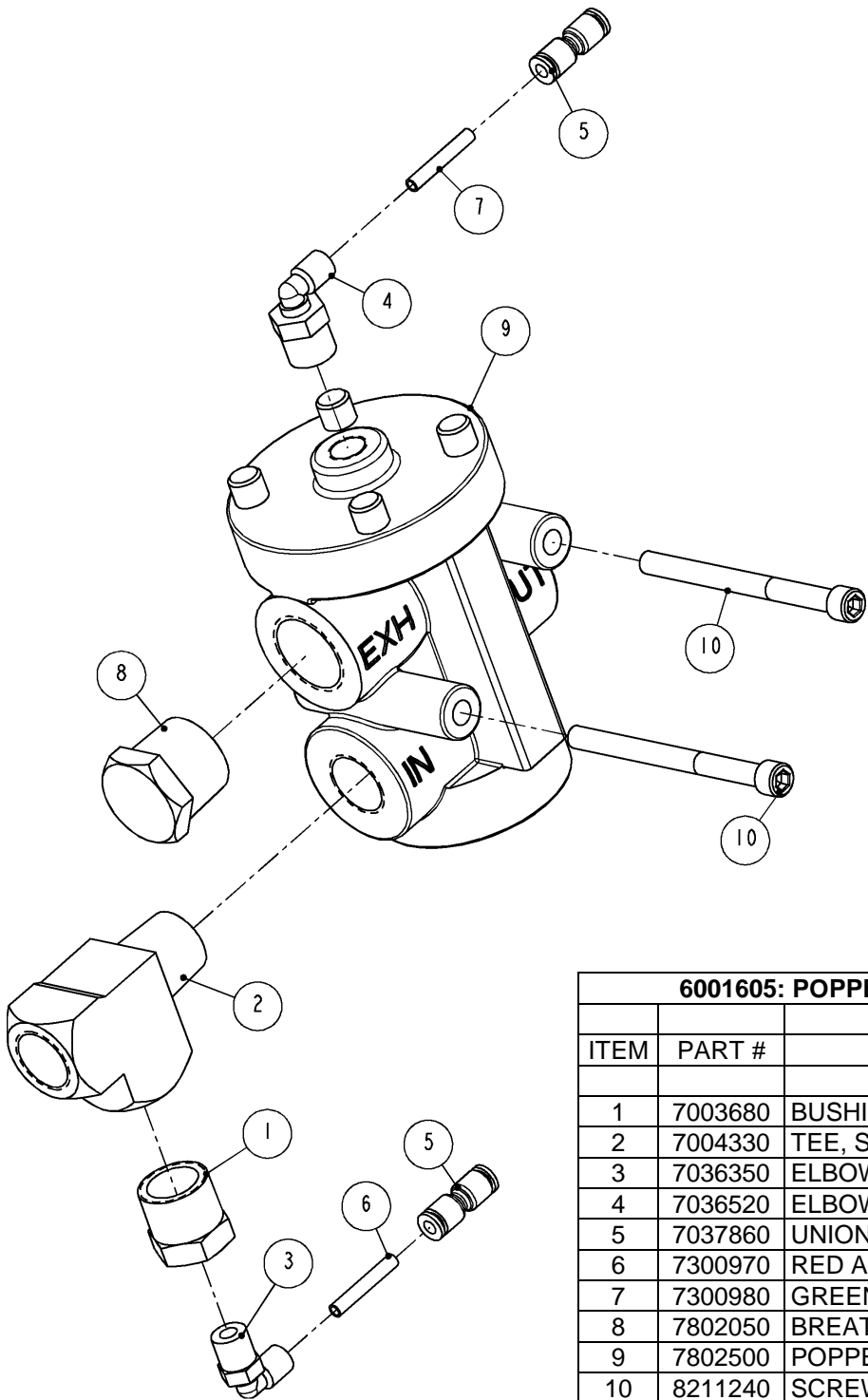

Figure 14 DEPTH GAUGE FOR 8" BLADE



6001605: POPPET VALVE ASSEMBLY			
ITEM	PART #	DESCRIPTION	QTY
1	7003680	BUSHING	1
2	7004330	TEE, STREET	1
3	7036350	ELBOW	1
4	7036520	ELBOW	1
5	7037860	UNION	2
6	7300970	RED AIR TUBE	1
7	7300980	GREEN AIR TUBE	1
8	7802050	BREATHER VENT FILTER	1
9	7802500	POPPET VALVE	1
10	8211240	SCREW	2

POPPET VALVE IS USED WITH MODEL "77" WITH TWO TRIGGERS.

Figure 15 POPPET VALVE ASSEMBLY

WIRING DIAGRAM

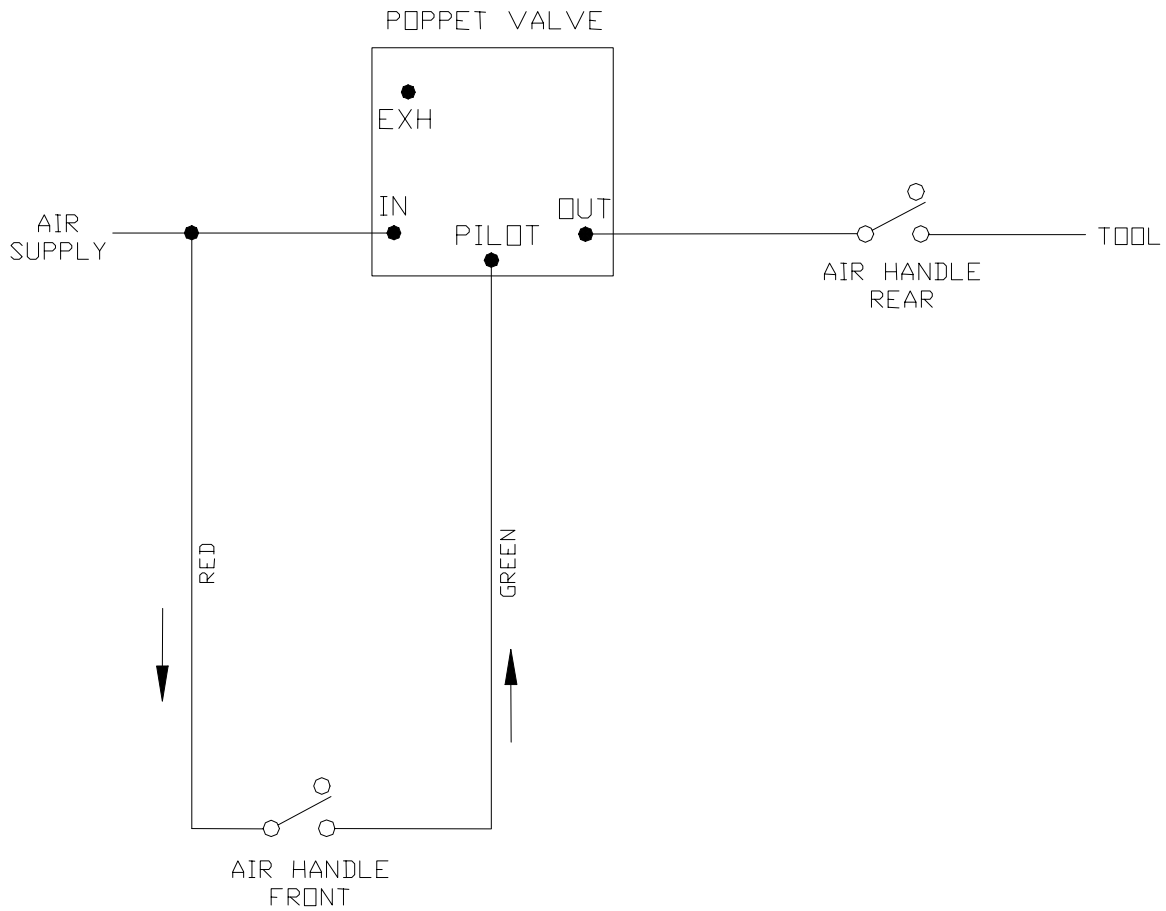

This wiring diagram is for model "77" with two triggers. As shown on the diagram above, two triggers option requires poppet valve (Kentmaster part No. 6001605).

Figure 16 WIRING DIAGRAM

[ENGLISH]

GENERAL INFORMATION

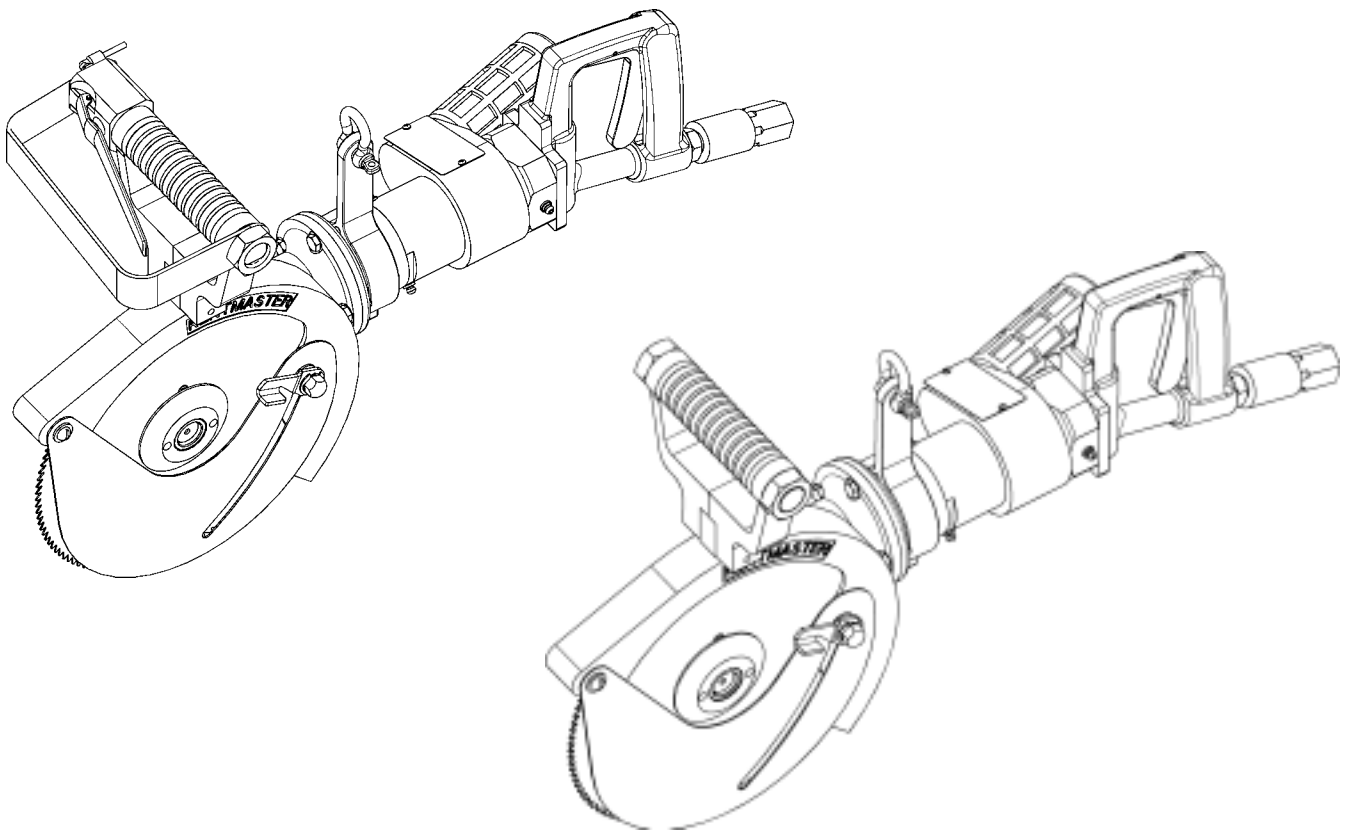

MODELS

“77” ALL PURPOSE BREAKING SAW WIT TWO TRIGGERS

“77” ALL PURPOSE BREAKING SAW WIT ONE TRIGGER

SERVICE CENTERS

KENTMASTER LTD. (U.K)

16 AVONBANK INDUSTRIAL CENTRE
WEST TOWN ROAD
AVONMOUTH - BRISTOL BS11 9DE
UNITED KINGDOM

☎ TELEPHONE: ++ 44- (0) 117- 9235035
FAX: ++ 44- (0) 117- 9829010

KENTMASTER MFG. CO., INC.

1801 SOUTH MOUNTAIN AVE.
MONROVIA, CALIFORNIA 91016
UNITED STATES OF AMERICA

☎ TELEPHONE: (626) 359-8888
FAX: (626) 303-5151

NOTICE TO EMPLOYER AND PURCHASER OF TOOL
NOTICE TO SAFETY DIRECTOR

You have purchased a powerful tool that, if misused, can cause severe injury and harm to your employees. You must instruct your employees in the safe and proper use of this tool and to follow the safety procedures and instructions that have been supplied by the manufacturer of this tool. Please follow the following instructions.



1. Instruct tool operators to test the tool each day before using it to be sure it does not malfunction. Remove and repair any tool that malfunctions.
2. Instruct tool operators to immediately stop using a tool that malfunctions or is defective.
3. Instruct personnel to immediately remove all tools that malfunction. Be sure to disconnect tool from power supply.
4. Instruct all personnel to stay clear of tool, and not to stand or walk in front of, or next to tool when in use.
5. Point out to all personnel the dangers related to the misuse of tool and the importance of following safety procedures and instructions.
6. Do not make, or allow others to make, alterations or modifications to this tool. Replace all lost or illegible labels.
7. Follow all safety, installation and maintenance instructions provided with this tool. Establish proper safety procedures in accordance with local and national requirements to prevent accidental energizing of tool that can cause injuries.
8. If this tool is sold or change in ownership takes place, you must provide the new owner all safety instructions, notices and maintenance instructions you were originally provided. You can obtain additional copies of the instructions from Kentmaster, free of charge upon request.
9. Give copies of instructions to: **(A) Tool Operators**
(B) Maintenance Supervisor
(C) Clean-up Supervisor



GENERAL INFORMATION



COVERING: SAFETY PRECAUTIONS AND PLACING INTO SERVICE
AIR POWERED ALL PURPOSE BREAKING SAW

READ THIS MANUAL CAREFULLY BEFORE INSTALLING, OPERATING OR SERVICING THIS TOOL

IT IS THE RESPONSIBILITY OF THE EMPLOYER TO PLACE THIS INFORMATION INTO THE HANDS OF THE OPERATOR.

PLACING INTO SERVICE

-  **WARNING** = Hazards or unsafe practices which could result in severe personal injury, death or substantial property damage.
-  **CAUTION** = Hazards or unsafe practices which could result in minor personal injury, product or property damage.
-  **NOTICE** = Important installation, operation or maintenance information.

-  **WARNING** Installation, adjustment repair and maintenance of this tool must be made by trained and qualified personnel.
-  **WARNING** Always disconnect power supply from tool before:
- (A) Installing or removing blade from tool.
 - (B) Making repairs or adjustments to the tool.
 - (C) performing maintenance or cleanup work.

INSTALLATION INSTRUCTIONS

MAINTENANCE

 **WARNING** ONLY TRAINED AND QUALIFIED PERSONNEL ARE TO PERFORM MAINTENANCE AND SERVICE TO THIS TOOL.

THE COMPRESSED AIR DISTRIBUTION SYSTEM MUST BE LARGE ENOUGH TO SUPPLY AN ADEQUATE VOLUME OF CLEAN AND DRY COMPRESSED AIR TO THE TOOL.

1. MAKE ALL NECESSARY LINE CONNECTIONS TO THE TOOL.
2. AN AIR FILTER-REGULATOR-LUBRICATOR (PART NO. 7200030) MUST BE INSTALLED IN AIR SUPPLY FOR EACH TOOL.
3. FILL LUBRICATOR WITH KENTMASTER AIR MIST OIL (PART NO. 7903050). SET DRIP RATE ACCORDING TO INSTRUCTIONS SUPPLIED. TURN ADJUSTMENT ON SIGHT FEED DOME TO INCREASE/DECREASE OIL DELIVERY. MONITOR THE DEVICE BEING LUBRICATED AND READJUST IF NEEDED.
4. TOOL REQUIRES GREASING AT START OF EACH SHIFT. GREASE FOUR (4) LOCATIONS USING KENTMASTER GREASE GUN (PART NO. 4501470) AND GREASE (PART NO. 7903070).
5. TOOL REQUIRES 40 S.C.F.M. OF AIR @ 90 P.S.I. AIR PRESSURE.
6. FLUSH AIR MOTOR AT END OF EACH DAY'S USE BY SQUIRTING A FEW SQUIRTS OF KENTMASTER AIR OIL MIST (PART 7903050) DIRECTLY INTO THE AIR INLET PORT. RUN TOOL A FEW SECONDS TO COAT AND PROTECT THE AIR MOTOR AND INTERNAL PARTS OF TOOL

KENTMASTER MFG. CO., INC. 1801 SOUTH MOUNTAIN AVE., MONROVIA, CALIFORNIA 91016 UNITED STATES OF AMERICA
☎ **TELEPHONE:** (818) 359-8888 **FAX:** (818) 303-5151

7. A BALANCER IS REQUIRED FOR OPERATION AND USE OF THIS TOOL. WEIGHT OF TOOL MUST FALL WITHIN WEIGHT RANGE OF BALANCER.
8. INSTALL BALANCER ABOVE WORK AREA. BALANCER MUST HAVE SUFFICIENT VERTICAL TRAVEL SO OPERATOR CAN REACH ENTIRE WORK AREA WITH TOOL WITHOUT STRAIN.
9. ADJUST BALANCER ACCORDING TO THE OPERATOR'S PREFERENCE AND COMFORT.

**WARNING**

WE STRONGLY SUGGEST THAT AN ADDITIONAL SAFETY CHAIN BE USED TO CHAIN BALANCER TO OVERHEAD TROLLEY. THIS ADDITIONAL MEASURE OF SAFETY WILL HELP REDUCE INJURIES.

OPERATING INSTRUCTIONS

**WARNING**

ONLY TRAINED PERSONNEL ARE TO OPERATE THIS TOOL.

1. HOLD TOOL FIRMLY AT BOTH TRIGGER HANDLES. SQUEEZE TRIGGERS SIMULTANEOUSLY TO ACTIVATE TOOL.
2. DO NOT EXERT EXCESSIVE PRESSURE. ALLOW TIME FOR THE TOOL TO CUT.

MAINTENANCE

**WARNING**

ONLY TRAINED AND QUALIFIED PERSONNEL ARE TO PERFORM MAINTENANCE AND SERVICE TO THIS TOOL.

1. FOLLOW PROCEDURES NO. 3 TO 6 OF INSTALLATION INSTRUCTIONS.

BLADE REMOVAL AND CLEANING.

**WARNING**

ALWAYS DISCONNECT POWER SUPPLY FROM TOOL BEFORE INSTALLING OR REMOVING BLADE FROM TOOL.

**WARNING**

ALWAYS WEAR WIRE MESH GLOVES WHEN INSTALLING OR REMOVING BLADES FROM TOOL.

1. REMOVE COLLAR (ITEM NO. 1, FIG. NO. 1).
2. REMOVE BLADE (ITEM NO. 2, FIG. NO. 1).
3. CLEAN ALL PARTS REMOVED WITH SOAP AND WATER.
4. SHARPEN OR REPLACE BLADES WHEN NECESSARY.
5. REASSEMBLE IN REVERSE ORDER.

SERVICE

1. KEEP GOOD RECORDS OF ALL SERVICE ACTIVITY AND INCLUDE TOOL IN YOUR PREVENTIVE MAINTENANCE PROGRAM.
2. USE ONLY GENUINE KENTMASTER REPLACEMENT PARTS TO ASSURE PROPER PERFORMANCE OF TOOL.
3. CONTACT THE KENTMASTER SUPPLIER NEAREST YOU FOR PARTS AND CUSTOMER SERVICE INFORMATION.

DECLARATION OF CONFORMITY

DECLARATION OF CONFORMITY

DECLARATION DE CONFORMITE -DECLARACION DE CONFORMIDAD- ERKLARUNG BEZUGLICH EINHALTUNG DER VORSCHRIFTEN
DICHIARAZIONE DI CONFORMITA . CONFORMITEITSVERKLARING

MANUFACTURED BY:

FABRIQUE PAR:
FABRICADA POR:
HERGESTELLT VON:
FABBRICATO DA:
VERVAARDIGD DOOR:

KENTMASTER MFG CO., INC.

**1801 SOUTH MOUNTAIN AVE.
MONROVIA, CALIFORNIA 91016
UNITED STATES OF AMERICA
TELEPHONE (626) 359-8888 FAX (626) 303-5151**

TYPE / SERIES: ALL PURPOSE BREAKING SAW

TYPE / SERIE:
TIPO / SERIE:
TYP / SERIE:
TIPO / SERIE:
TYPE / SERIE:

MODEL: 77

MODELE:
MODELO:
MODELL:
MODELLO:
MODEL:

SERIAL NO. RANGE: XXXXX

N SERIE: • GAMA DE No. DE SERIE: • SERIEN-NR.-BEREICH: • NUMERI DI SERIE: • SERIENUMMERS:

This product complies with the following European Community Directives:

Ce produit est conforme aux directives de la Communauté européenne suivantes:
Este producto cumple con las siguientes Directrices de la Comunidad Europea:
Dieses Produkt erfüllt die folgenden Vorschriften der Europäischen Gemeinschaft:
Questo prodotto è conforme alle seguenti direttive CEE:
Dit produkt voldoet aan de volgende EG-richtlijnen:

89/392/EEC, 91/368/EEC, 93/44/EEC, 93/68/EEC

The following Standards were used to verify compliance with the Directives:

Les normes suivantes ont été utilisées pour vérifier la conformité avec les Directives:
Las siguientes Normas se usaron para verificar el cumplimiento de las Directrices:
Folgende Normen wurden angewandt, um Erfüllung der Vorschriften zu bestätigen:
Per verificare la conformità del prodotto alle direttive sono stati usati i seguenti standard:
De volgende normen zijn gebruikt om naleving van de richtlijnen te bevestigen:

EN 292

Approved by: _____

RALPH KARUBIAN MONROVIA, CA. U.S.A

(Engineering Manager) (Directeur technique) (gerente de ingeniería) (verantwortlicher Konstruktionsleiter) (Responsabile tecnico) (ondersteunend technisch manager)

Date: AUG - 1 - 1995

Kentmaster Worldwide Location

Kentmaster Equipment (Aust) PTY.LTD.
Unit 2,24 Central Court
Browns Plains Qld. 4118
Australia

Telephone: (07) 3806-8400
Fax: (07) 3806-7933
Australia@Kentmaster.com

Kentmaster do Brasil, Ltda.
Av. Dr. Joao Teodoro No. 805
Bairro De Vila Rezende
13405-240 Piracicaba, SP,
Brazil

Telephone #1: (019) 3 413 3113
Telephone #2: (019)983-4973
Fax: (019) 3 413 3113
Brazil@Kentmaster.com

Kentmaster (IRL) LTD.
Benamore, Dublin Road.
Roscrea,
CO, Tipperary,
Ireland

Telephone: (353) 0505-23292
Fax: (353) 0505-23299
Ireland@Kentmaster.com

Kentmaster Equipment (NZ) LTD.
5 Cooper Street
Havelock North
New Zealand

Telephone #1: (64) 6 8777 857
Telephone #2: 0800 KENTMASTER
Fax: (64) 6 8777 858
NewZealand@Kentmaster.com

Kentmaster South Africa (PTY) LTD.
Johannesburg - S. Africa
Unit 54 Sunnyrock Park
Sunrock Close, Germiston
South Africa

Telephone: (27) 11-455-3748
Fax: (27) 11-455-3749
SouthAfrica@Kentmaster.com

Kentmaster (UK) LTD.
Unit 16 Avonbank Ind. Centre
West Town Rd, Avonmouth-Bristol,
BS11 9DE
England

Telephone: (44) 117-923-5035
Fax: (44)-117-932-9010
UK@Kentmaster.com

Kentmaster Mfg. Co., Inc.
1801 South Mountain Ave.
Monrovia, CA, 91016
USA

Telephone #1: (626) 359-8888
Telephone #2: (800) 421-1477
Fax: (626) 303-5151
info@Kentmaster.com

Kentmaster Omaha
4417 South 139th Street
Omaha, NE, 68137
USA

Telephone #1: (402) 896-3355
Telephone #2: (800) 367-3181
Fax: (402) 896-3311
Omaha@Kentmaster.com

INDEX

<i>OPERATING AND SAFETY INSTRUCTIONS</i>	2
OPERATING INSTRUCTIONS	3
MAINTENANCE	3
<i>SERVICE</i>	4
<i>PARTS BOOK</i>	4
GEAR HOUSING DISASSEMBLY	9
GEAR HOUSING REASSEMBLY	9
GEAR CASE AND AIRMOTOR DISASSEMBLY	13
GEAR CASE AND AIRMOTOR REASSEMBLY	13
<i>WIRING DIAGRAM</i>	16
<i>GENERAL INFORMATION</i>	19
INSTALLATION INSTRUCTIONS	19
MAINTENANCE	19
OPERATING INSTRUCTIONS	20
MAINTENANCE	20
SERVICE	20
<i>DECLARATION OF CONFORMITY</i>	21
<i>Kentmaster Worldwide Location</i>	22
<i>INDEX</i>	23
<i>FIGURES - INDEX</i>	23

FIGURES - INDEX

Figure 1 MODEL 77 – BLADE REPLACEMENT	4
Figure 2 MODEL “77” – MAIN ASSEMBLY	5
Figure 3 BOM FOR MODEL “77”	6
Figure 4 GEAR-NOSE ASSEMBLY FOR 8”, 9” & 10” BLADE	7
Figure 5 GEAR-NOSE ASSEMBLY FOR 11” & 12” BLADE	8
Figure 6 FRONT HANDLE WITH AIR SWITCH	9
Figure 7 FRONT HANDLE WITHOUT SWITCH	10
Figure 8 REAR HANDLE ASSEMBLY	10
Figure 9 AIR MOTOR AND GEAR CASE ASSEMBLY	11
Figure 10 DRIVE SIDE ASSEMBLY BOM	11
Figure 11 AIR MOTOR ASSEMBLY	12
Figure 12 GEAR CAGE ASSEMBLY	13
Figure 13 DEPTH GAUGE FOR 9” & 10” BLADE	14
Figure 14 DEPTH GAUGE FOR 8” BLADE	14
Figure 15 POPPET VALVE ASSEMBLY	15
Figure 16 WIRING DIAGRAM	16